

# Ethernet Dual Homing

## MAC Flushing

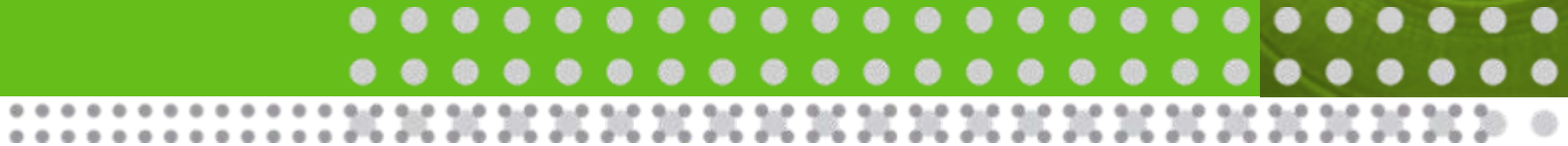

Don Fedyk

Florin Balus

Wednesday, 20 May 2009

## Problem Statement

---

Minimize loss of packets in Dual homing environments between domains

- Between domains where learning is used because within a domain other techniques are available
- Loss is minimized by flushing or unlearning MAC addresses associated with intermediary bridges or paths.

Primary cause of lost packets is due to response time of learning the new destination bridges that can reach existing MACs

- Traffic is black holed during the time the new path is learned
- Mechanisms to bridge traffic that would be black holed during the period it take to relearn are “out of scope”

# Requirements

---

## Dual Homing Overall Requirements

- Covers Ethernet Dual Home path/tree Technologies
  - RSTP, MSTP, SPB, SPBB
  - 1+1 Protection PBB-TE, G.8031, G.8032
  - Multi-chassis LAG, or equivalent
- Includes Ethernet Encapsulations
  - C-VLANs
  - S-VLAN (PB)
  - B-VLANs (PBB, PBB-TE)
  - VPLS
- Hierarchical
  - Able to handle Dual homing at the lowest level in the system

# IEEE 802.1 Dual Homing Environments - xSTP based

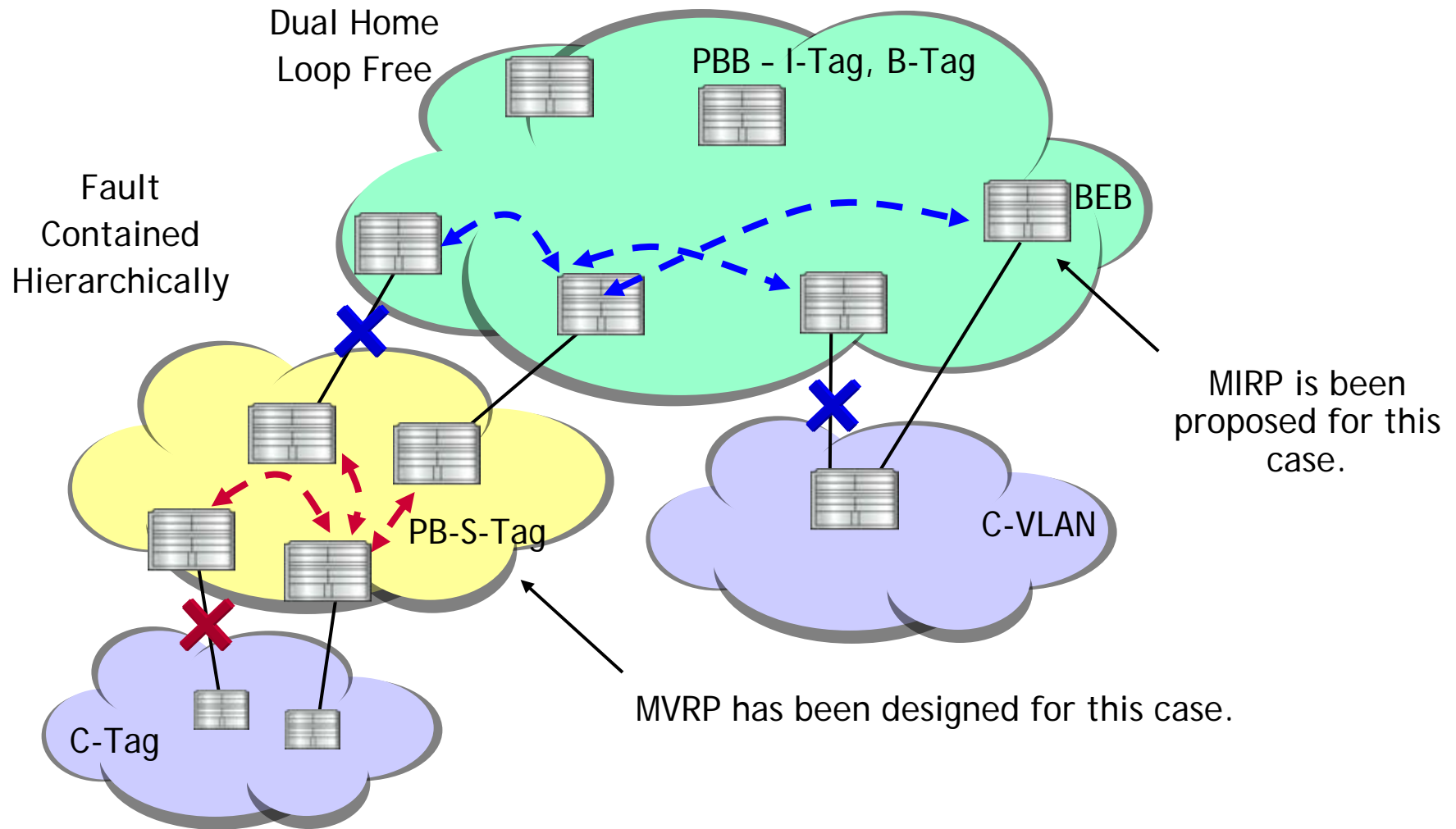

# IEEE 802.1 Dual Homing Environments - new Control Plane options

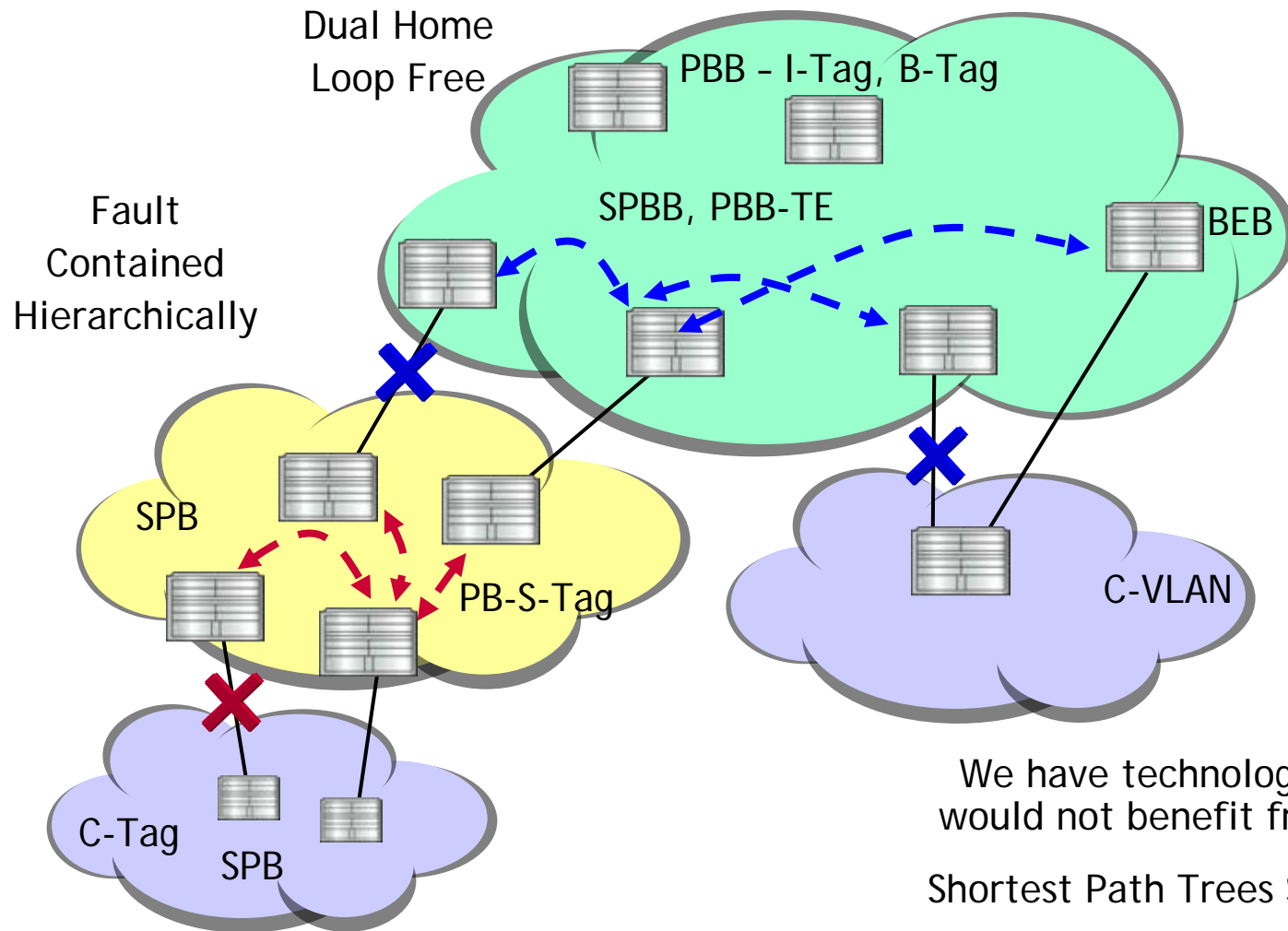

We have technologies that would not benefit from MRP.

Shortest Path Trees SPBB. SPB

PBB-TE

# Ethernet (IEEE, ITU, IETF) Dual Homing Environments

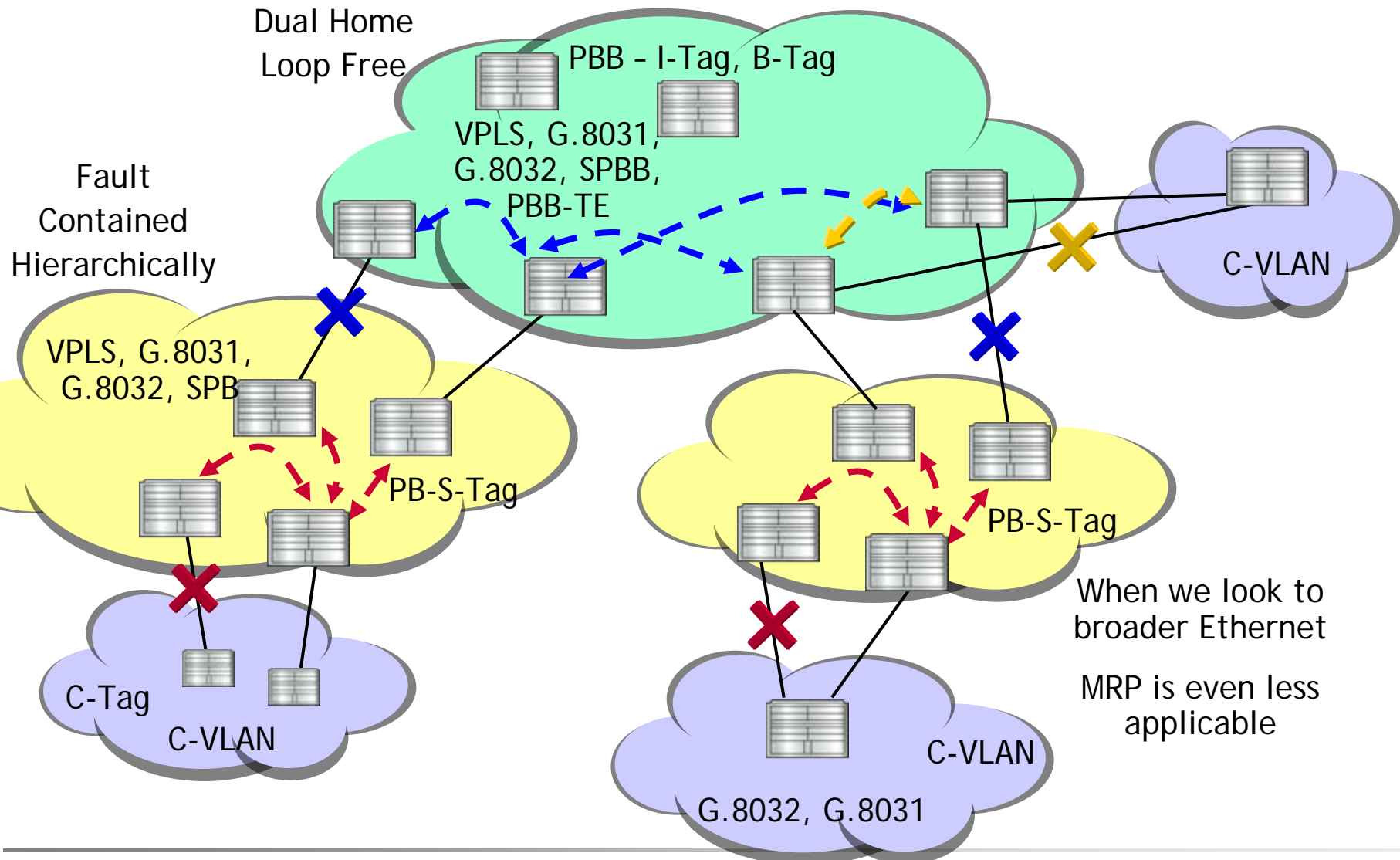

# PBB Blackholing discussion

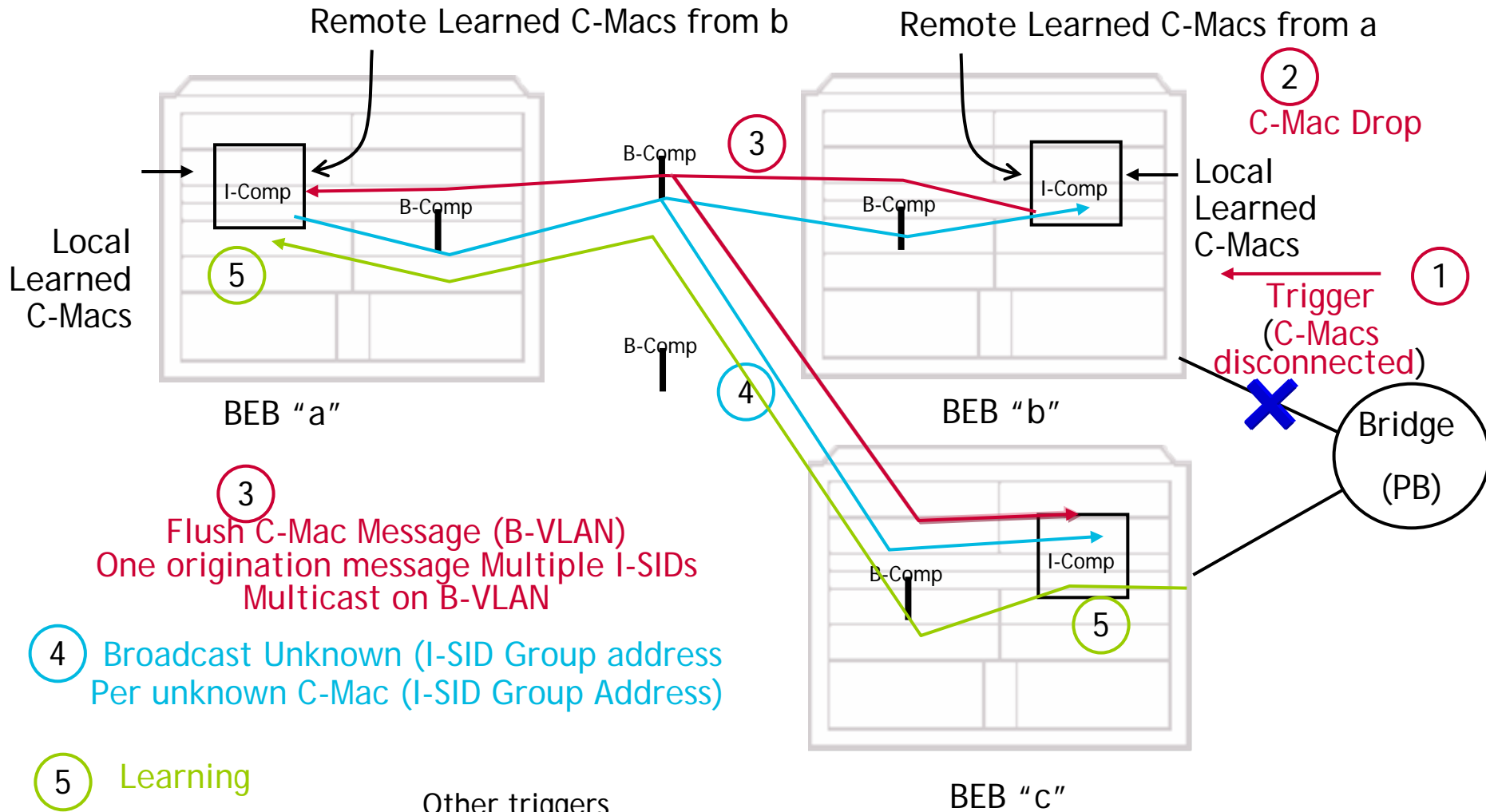

3 Flush C-Mac Message (B-VLAN)  
One origination message Multiple I-SIDs  
Multicast on B-VLAN

4 Broadcast Unknown (I-SID Group address  
Per unknown C-Mac (I-SID Group Address))

5 Learning

- Other triggers
- xSTP TCN
  - Link activation/failure
  - New mechanism

# Backbone Dual Homed Flush Message Details

---

## Requirements

- Targeted at I-SIDs not Backbone components
- Utilizes Group address for replication
- Granularity
  - Flush these C-MACs from my BEB (B-MAC) for I-SID x
    - Only flush C-MACs needed
    - Slow too granular?
  - Flush all C-Mac from my BEB (B-MAC) for I-SID x
    - Carries Multiple I-SIDs
    - Some MACs may be flushed that are still reachable
    - Faster
  - Flush all C-MACs for this BEB (B-MAC) in that B-VID
    - May be desirable if there are large changes
    - Overkill Affects all traffic to the BEB.
  - B-MACs - Port or Node (Bridge) based
- Flush Type
  - Flush all but Mine (B-MAC) (from BEB) action at Receiver
    - Positive New connectivity to me I'm OK but things may have changed
  - Flush all from Me. (B-MAC) (all BEBs) action at Receiver
    - Negative I lost some connectivity Better relearn everything



# Dual Homed Rings G.8032

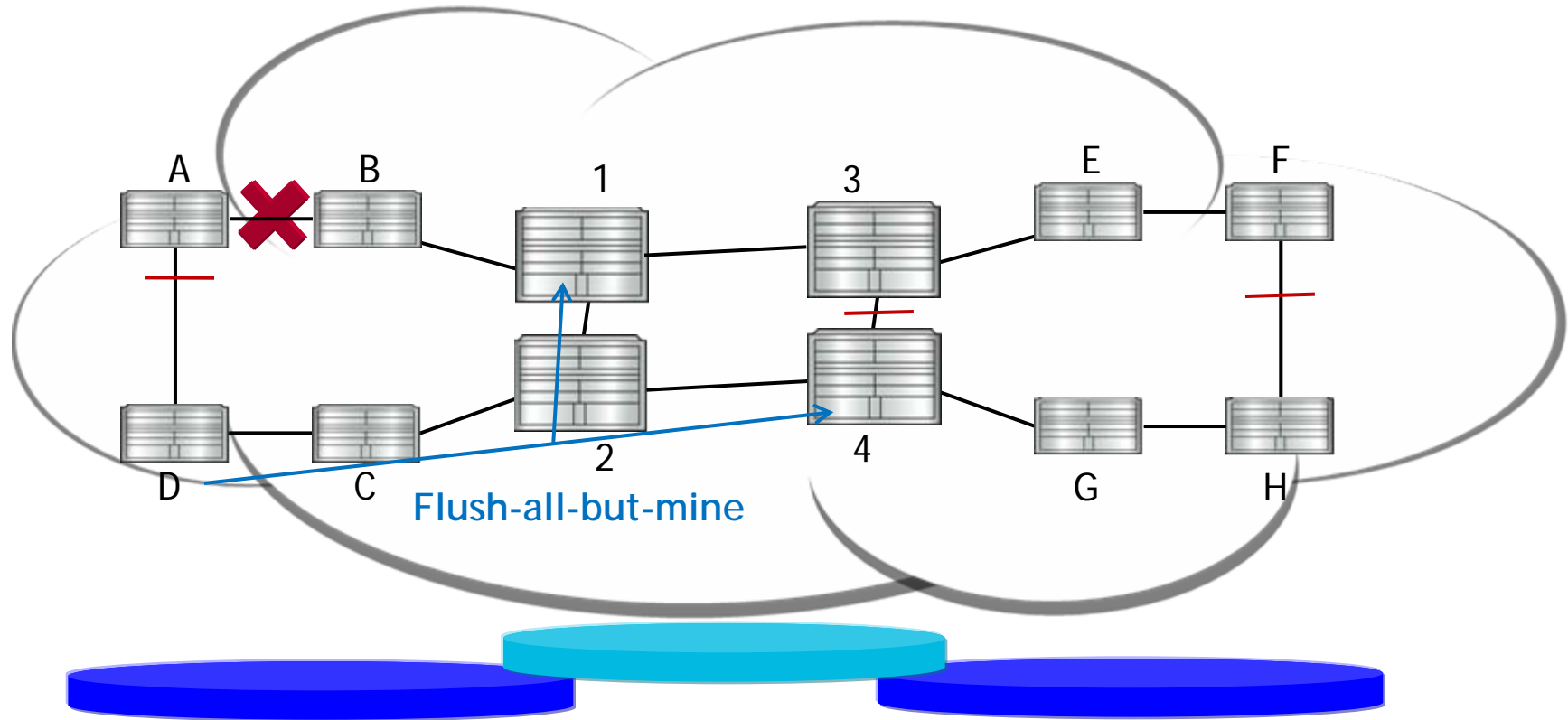

STP TCNs - not available; C-tag/PB/PBB domain

Possible triggers - link/nodal failure/activation, changes in ring configuration

Hierarchy is not implicit but may be useful

# VPLS with G.8032 Access Rings - Service Provider network

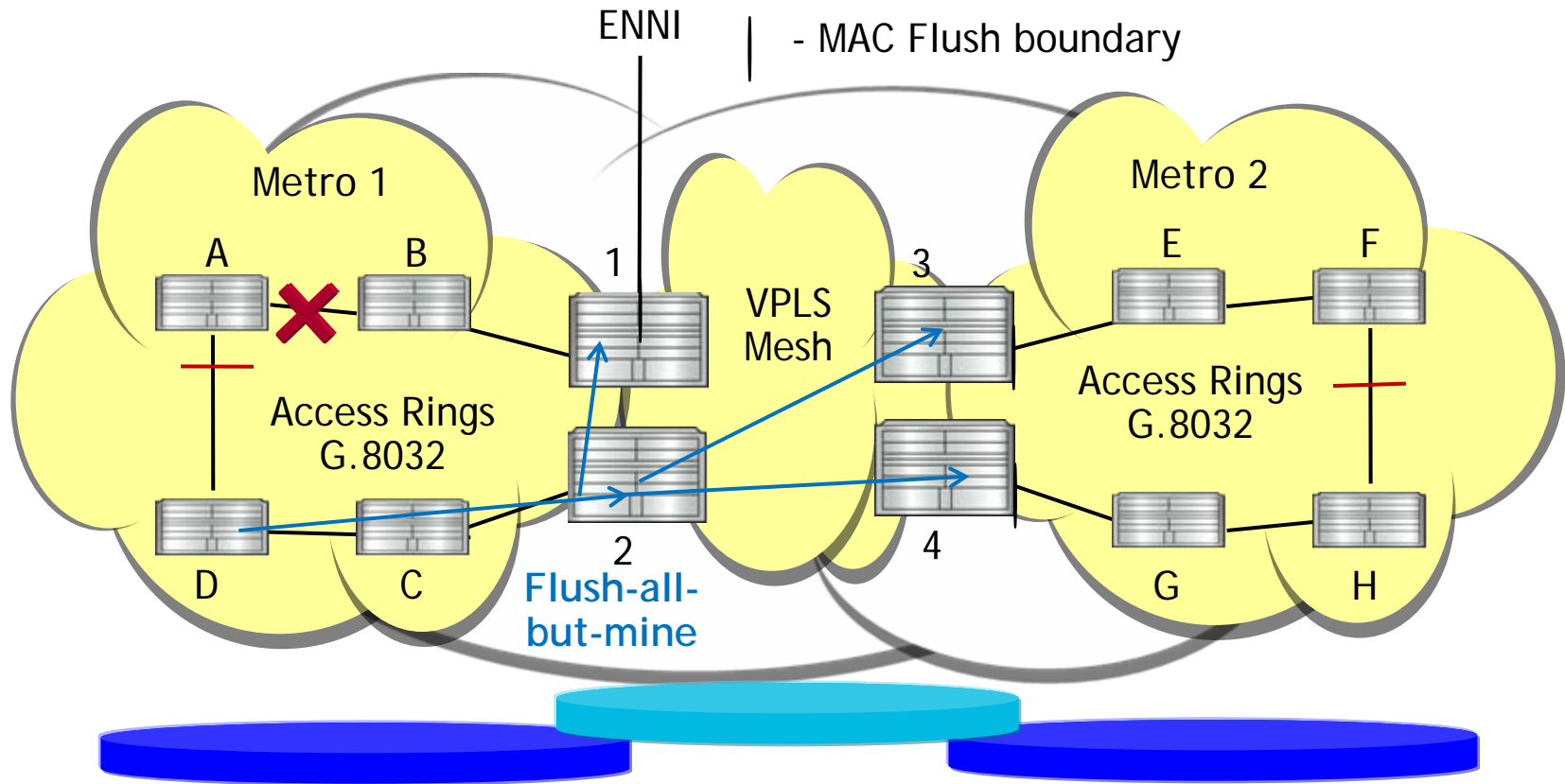

STP TCNs - not available; C-tag/PB/PBB domain

Possible triggers - link/nodal failure/activation, changes in ring configuration

MAC Flush must be propagated to other Rings in Metro 1 & into VPLS Mesh but does not need to be propagated into Metro 2 (implied Hierarchy)

# PB Environments

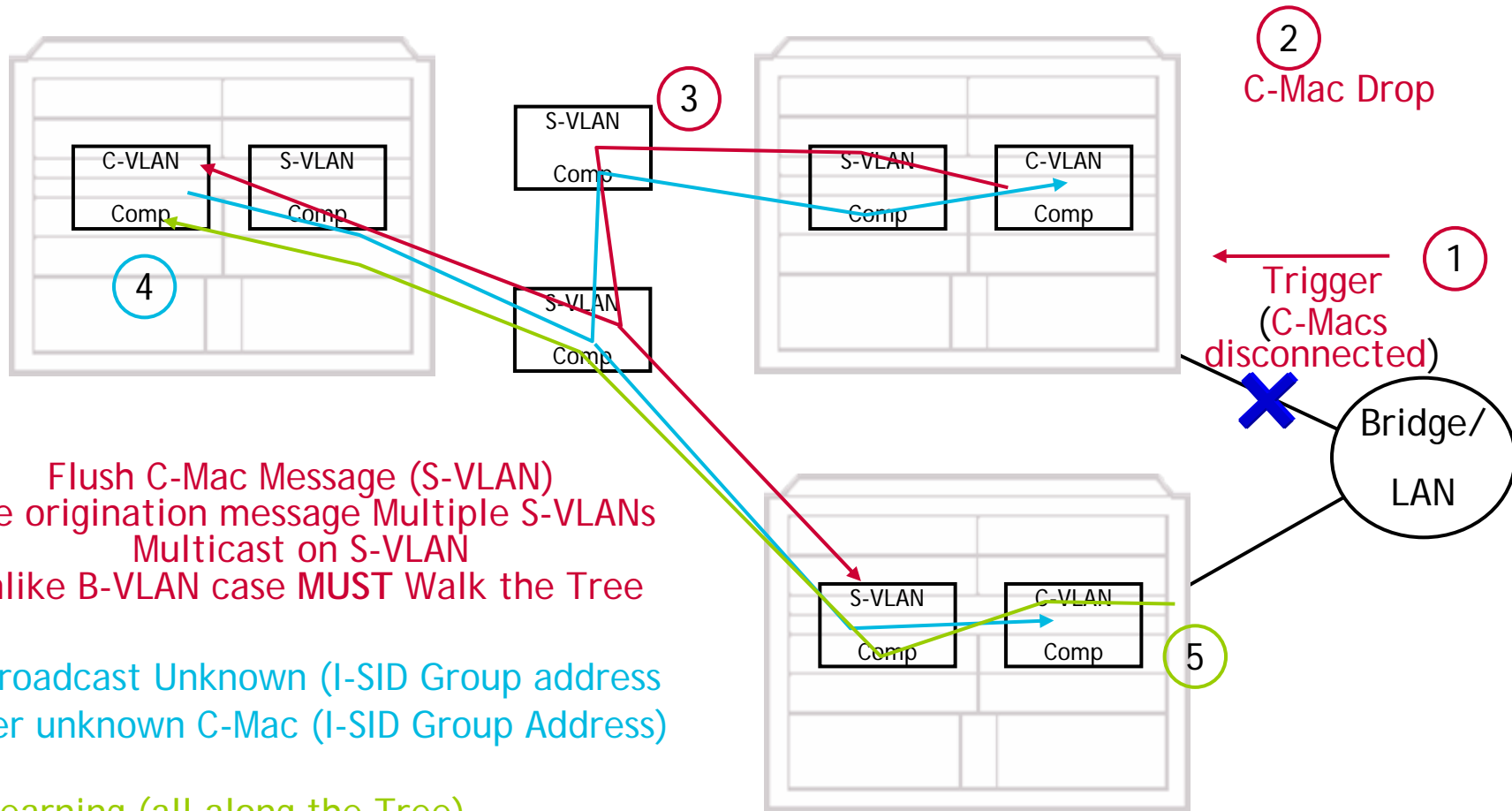

3 Flush C-Mac Message (S-VLAN)  
 One origination message Multiple S-VLANs  
 Multicast on S-VLAN  
 Unlike B-VLAN case MUST Walk the Tree

4 Broadcast Unknown (I-SID Group address  
 Per unknown C-Mac (I-SID Group Address)

5 Learning (all along the Tree)

## Observations

---

- Policy should be set to have a set of Triggers for interdomain MAC flushing.
- Within a domain control planes can manage connectivity. It is primarily between domains.
  - Rings have more requirements.
- PBB is unique in that the edge only receives messages.
  - Less of an argument for MRP function (no need to follow a tree).
- PBB-TE, G.8031 do not support MRP natively
- CFM is more universal to all applications - requires just a new opcode
  - Has hierarchy built in
  - Lots of implementations - Applicable to broader Ethernet
  - Is expandable - Flags, TLV structure to accommodate CMAC(s), BMAC(s), ISID List

## Proposal

---

Define standard MAC flush mechanisms that can be carried in CFM which would be applicable most (all?) places CFM is available.

- Augment CFM with Standard Message types to trigger MAC flushing so they can be used in broader Ethernet environments.