

Tutorial on Synchronization: A Key Function in Time-Sensitive Networking and Beyond

Kishan Shenoi, Stefano Ruffini, Marc Weiss, Lee Cosart, Silvana Rodrigues,
Geoffrey Garner, Jordon Woods, and Max Turner

Tutorial, IEEE 802 Plenary Session, March 2, 2021

Abstract

Synchronization is crucial in many networking technologies, e.g., cellular networks, Time-Sensitive Networking (TSN) and in the communication networks of various industry segments, e.g., telecommunication, industrial automation, etc.

This joint tutorial of the Workshop on Synchronization and Timing Systems ([WSTS](#)) and the [IEEE 802.1 Working Group](#) introduces the principles of synchronization, synchronization techniques, e.g., the Telecom and the TSN profiles of the IEEE 1588 Precision Time Protocol (PTP), and application areas such as industrial automation and automotive in-vehicle networks.

Disclaimer

- This presentation should be considered as the personal views of the presenters not as a formal position, explanation, or interpretation of IEEE.
- Per IEEE-SA Standards Board Bylaws, August 2020
“At lectures, symposia, seminars, or educational courses, an individual presenting information on IEEE standards shall make it clear that his or her views should be considered the personal views of that individual rather than the formal position of IEEE.”



++++
++++

WSTS 2021

30 Years in Sync: Time-Sensitive Everything for 5G and Connected Industries

This is a brief introduction to timing issues. For more information attend the tutorials and the full workshop:

Tutorials from 11:00 a.m. – 1:00 p.m. ET

- March 24: Timing and Synchronization Fundamentals
- March 25; Timing and Synchronization Applications

Workshop from 12:00 – 5:00 p.m. ET

- March 30: Timing in Telecom, Electric Power and Smart Cities
- March 31: Sync in Financial Services, Data Centers and Measurement
- April 1: Security, Resilience and Timing Sources
- Unscheduled talks available on demand

For more information on WSTS and the Tutorials visit <https://wsts.atis.org>

Workshop on Synchronization and Timing Systems



++++
++++
++++

Tutorial Outline

- Introduction to principles and use cases
- Clock technologies, modeling, and requirements
- IEEE 1588 PTP Telecom Profiles
- Q&A
- IEEE 802.1AS PTP profile for TSN
- IEC/IEEE 60802 TSN Profile for Industrial Automation
- IEEE P802.1DG TSN Profile for Automotive In-Vehicle Ethernet Communications
- Q&A



Speakers (ATIS WSTS)

- Kishan Shenoi



- Stefano Ruffini



- Marc Weiss

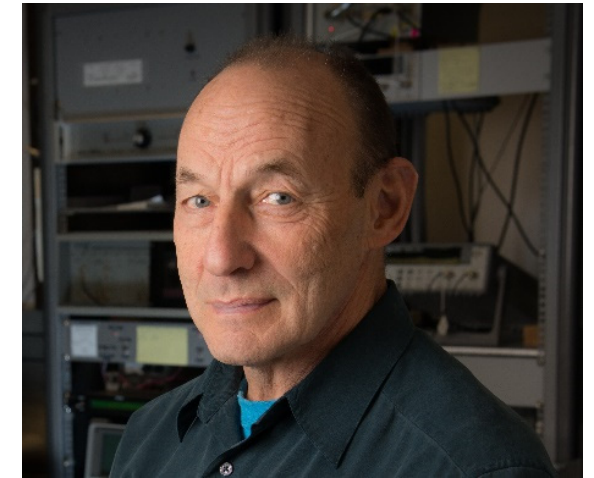

- Lee Cosart



- Silvana Rodrigues



Speakers' biographies

Kishan Sheno

received his bachelors, masters, and doctorate degrees from IIT-Delhi, Columbia University, and Stanford University, in 1972, 1973, and 1977, respectively. He is active in Standards development and active in the Steering Groups of WSTS and ITSF. He is named on 54 patents and has several publications including two books, Digital Signal Processing in Telecommunications (1995) and Synchronization and Timing in Telecommunications (2009). Dr. Sheno is currently CTO of Qulsar, developing fit-for-purpose solutions for timing and synchronization.

Stefano Ruffini

joined Ericsson in 1993. He is an expert at Ericsson Research working on synchronization and transport solutions. He is currently an active contributor to ITU-T SG15 Q13 (serving as rapporteur) and other relevant synchronization standardization bodies, as well as serving as the chair of the International Timing and Sync Forum (ITSF). Ruffini holds a M.Sc. in telecommunication engineering from Sapienza University of Rome, Italy.

Marc Weiss

worked at NIST from 1979, specializing in time transfer techniques and statistics of timing systems. Since January 2014 he is now a consultant on precision timing systems. Marc founded and has led WSTS annually since 1992, which is now a sister conference to the European version, the ITSF. In addition, Dr. Weiss led the NIST program to support GPS development from 1980 until his retirement in 2014. He has worked on and published Relativity issues as they relate to GPS and to primary frequency standards. He has also specialized in Time-Scale Algorithms. He received his Ph.D. in Mathematical-Physics from the University of Colorado in 1981.

Lee Cosart

is a Research Engineer with Microchip. A graduate of Stanford University, his R&D activities have included measurement algorithms and mathematical analysis for which he holds several patents. He serves on, as chair, contributor and editor, the ATIS and ITU-T committees responsible for network synchronization standardization. His TimeMonitor software is used to collect and analyze synchronization and packet timing data and has been used in laboratories and networks throughout the world.

Silvana Rodrigues

works for Huawei as a Senior Engineer. She holds an Electronic and Electrical Engineering degree from University of Campinas, Brazil.

She is currently the associate rapporteur and editor of several recommendations at ITU-T SG15 Q13. She is a secretary of IEEE 1588 WG and participates in IEEE 802.1 TSN WG.

Speakers (IEEE 802.1)

- Geoffrey Garner



- Jordon Woods



- Max Turner



Speakers' biographies

Geoffrey Garner received his S.B. degree in Physics in 1976, S.M. degrees in Nuclear Engineering and Mechanical Engineering in 1978, and Ph.D. in Mechanical Engineering in 1985, all from M.I.T. He was a Member of Technical Staff at AT&T Bell Laboratories and then Lucent Technologies and became a Distinguished Member of Technical Staff in 1999. Since 2003 he has been a consultant in telecommunications and networking, specializing in network timing, jitter, synchronization, and related mathematical and simulation analysis and standards development. He has consulted for Huawei since 2008, and also for Samsung, Broadcom, Marvell, Hirschmann, Siemens, and Internet Photonics. He is active in IEEE 802.1, where he is editor of IEEE 802.1AS; ITU-T SG 15 Q13, where he is editor of several Recommendations; and IEEE 1588. He is author or co-author of several articles, conference papers, and patents, and primary author of over 300 standards contributions.

Jordon Woods is a strategic technologist for Analog Devices Industrial Ethernet Technology Group (IET). IET enables seamless and secure connection of customer products across the entire landscape of Industrial IoT. Woods has 35 years of experience in the semiconductor industry. He is familiar with a variety of Ethernet-based Industrial protocols including Profinet, EtherNet/IP, as well as IEEE TSN standards. He is also a voting member of the IEEE 802 working group defining new Ethernet standards for Time Sensitive Networks and the editor of the IEC/IEEE 60802 Time-Sensitive Networking Profile for Industrial Automation.

Max Turner holds a Diploma degree in Physics from the University of Ulm. He joined BMW in Munich at the end of 2002 where he worked on MOST and FlexRay physical layer specifications. From 2005 to 2008 Max was working at the BMW Technology Office in Palo Alto, California where he focussed on DSRC based V2x communication around IEEE802.11P and IEEE1609. After his return to Munich he started the introduction of Ethernet into Autosar (SocketAdaptor) and became part of the team developing the Diagnostics over IP (ISO13400) specification. Max was part of the team introducing Ethernet (e.g. SOME/IP and AVB) into BMW vehicles and was active in IEEE and AVnu to foster automotive Ethernet adaptations. Max spent two years at Jaguar Land Rover in Gaydon UK, where he worked on vehicle network architectures focussed on automated driving, before joining Ethernovia in Dec. 2019, where he serves as Automotive Network Architecture Lead, bringing OEM experience and latest semiconductor hardware design together.

Introduction to principles and use cases

Stefano Ruffini and Kishan Shenoi

stefano.ruffini@ericsson.com, kshenoi@qulsar.com

Principles

Kishan Shenoi

Frequency and Time

- A clock is a frequency device based on physics

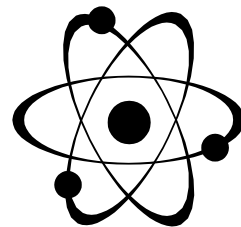

Provides “ticks” at precise intervals
e.g., Atomic Clocks, Quartz, MEMS, etc.

- Electronic systems count “ticks” for time interval

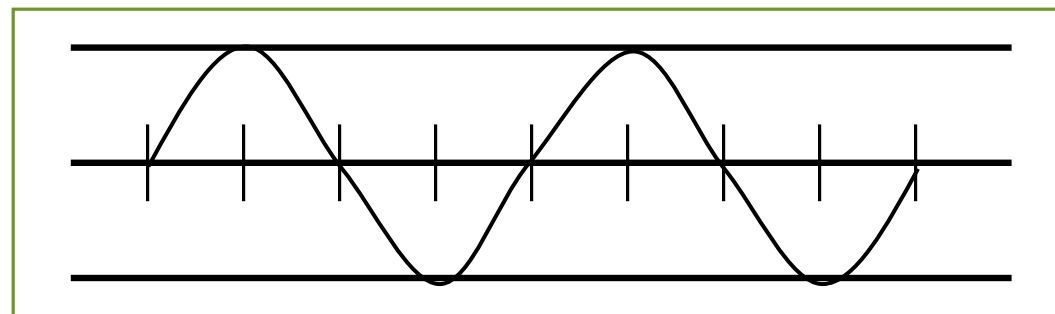

“Time-Clock”
provides the
time elapsed
since the “start”

- Time is steered to chosen reference, generally UTC
 - UTC: Defines the “start” plus corrections for astronomy

Alignment in Frequency, Phase & Time

Aligning (or Synchronization) of two Time Clocks implies:

Frequency B	=	Frequency A	Syntonization
Phase B	=	Phase A	Roll-over instant
Seconds B	=	Seconds A	Elapsed time equal
"Time": Same formatting convention, time-zone, etc.			

Clock is a frequency device, provides "ticks"

Electronic Systems count "ticks" for time interval

Time is a combination of a signal (event) and a label (time value)

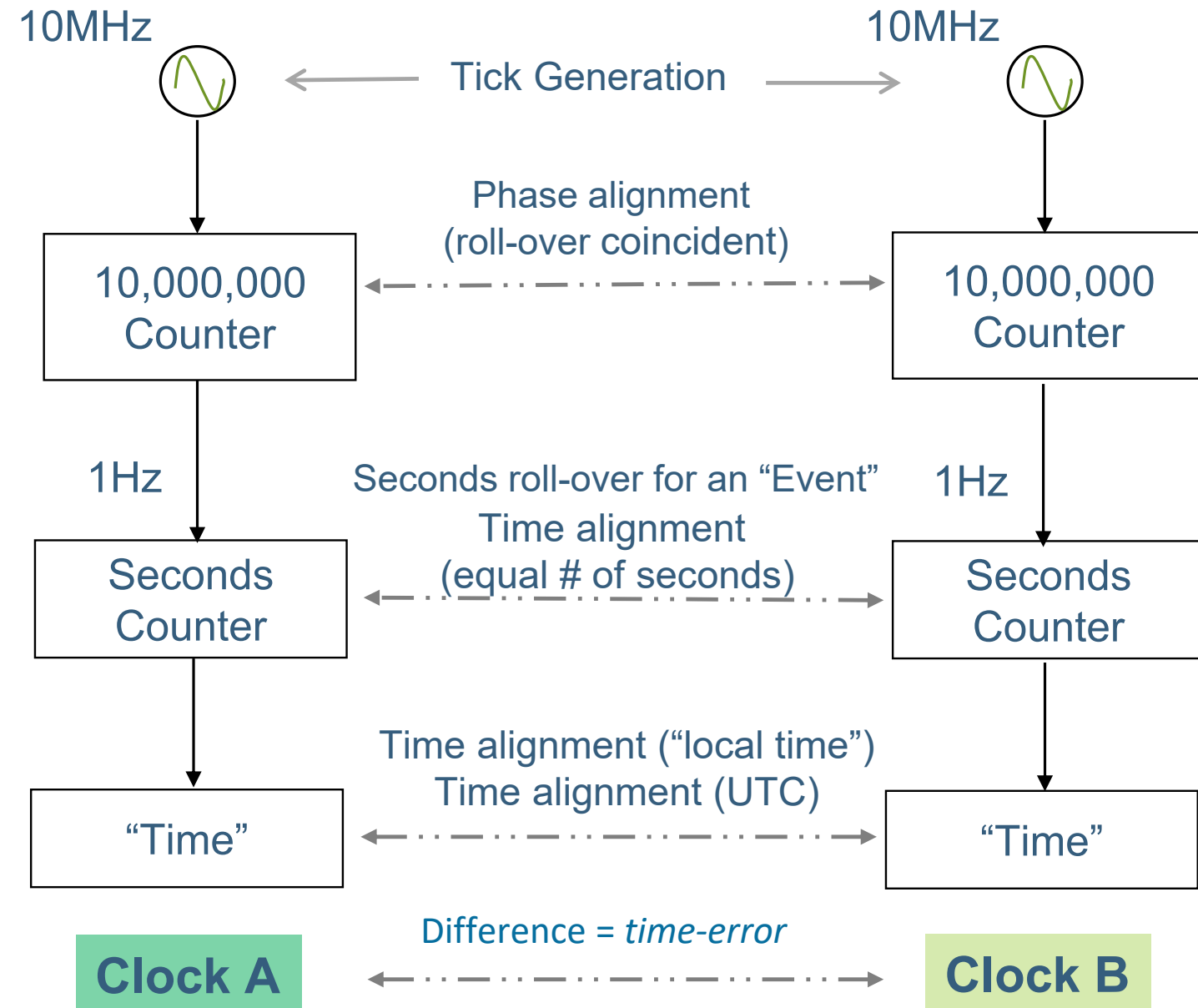

Time scales such as UTC

- Time is always measured against a reference clock. For example:
 - Some “clocks” are weighted averages of clocks, so-called paper clocks
 - GPS has its own time scale called GPS time, which is usually kept within ~10 ns of UTC, but is only required to be within 1 microsecond!
 - GPS also broadcasts a version of UTC based on the US Naval Observatory real-time UTC, UTC(USNO)
- UTC is a post-processed average of clocks from around the world
- Any real time UTC is a prediction for a given lab
 - UTC(NIST) in US, UTC(OP) in France, UTC(NPL) in UK, etc.

The Generation of Coordinated Universal Time, UTC

Any Real-Time UTC is only a Prediction,

A PLL with a one-month delay (There is a provisional “rapid” UTC published weekly)

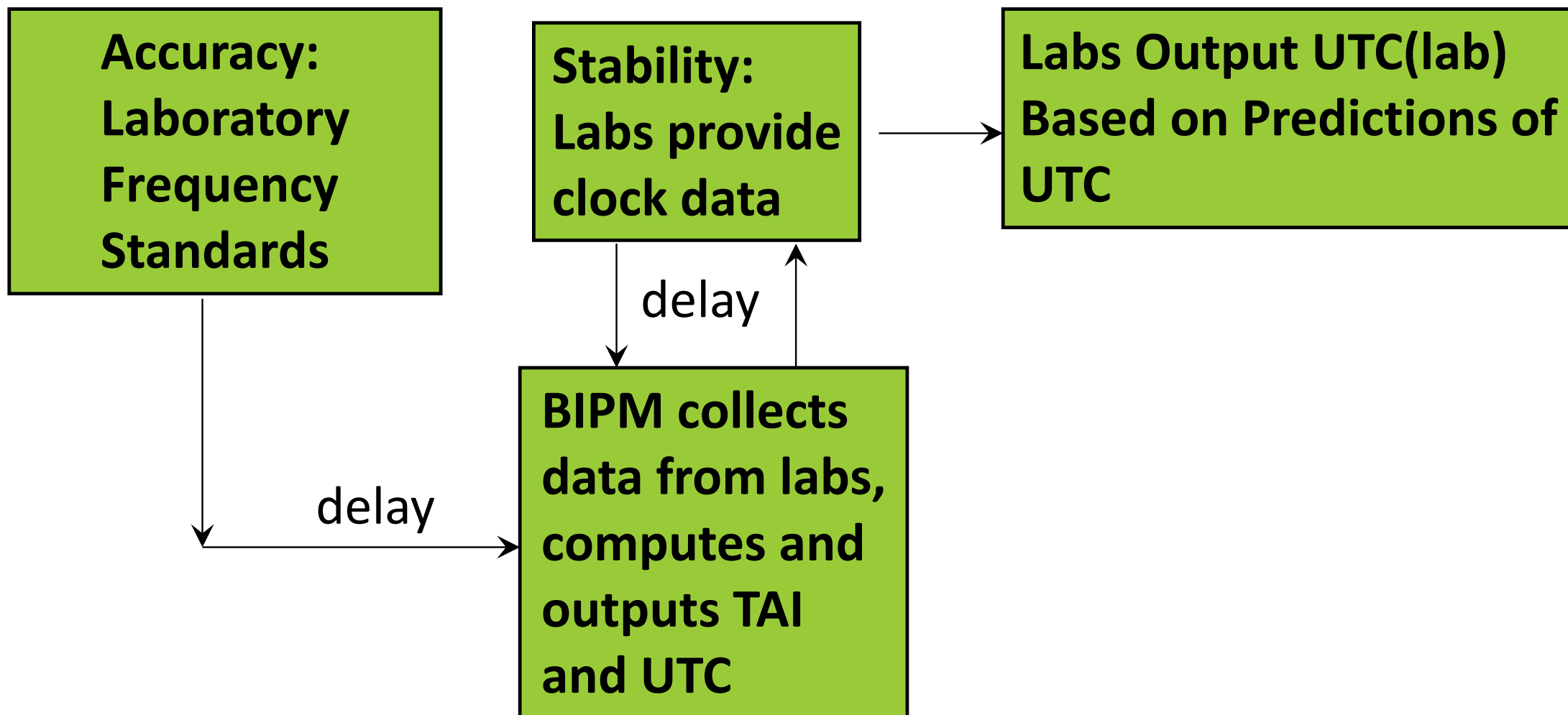

Time and Timescales

- Time is an artificial construct.
 - Choose an origin (“epoch”) that people can agree on
 - Count the number of seconds (milliseconds /microseconds /etc.) from the origin.
 - Define suitable units such as seconds and minutes and hours and days and so on to express the count from the origin
- Time Interval (e.g., 1 s) is based on a physical property of the Cesium atom.

Timescale	Epoch	Relationship	Leap Seconds	Other
TAI	Jan 1, 1958	Based on SI second	No	Continuous
UTC	Jan 1, 1972	TAI-UTC = 37sec	Yes	Discontinuous
UT-1	Jan 1, 1958	Earth’s rotation	No	Astronomical
GPS	Jan 6, 1980	TAI – GPS = 19sec	No	Continuous
Loran -C	Jan 1, 1958	UTC + 27 sec	No	Discontinuous
Local	Jan 1, 1972	TAI-UTC = 37sec	Yes	Discontinuous, Based on Time zone offset
PTP	Jan 1, 1970	TAI – PTP = 10sec	No	Continuous
NTP	Jan 1, 1900	UTC	Yes	Discontinuous

“discontinuous” timescale allows for jumps related to leap seconds

Synchronization Use Cases

Stefano Ruffini

Use cases requiring synchronization

- Synchronization (time and/or Frequency) is a key component in various contexts
- Traditionally required in “TDM” transport networks (SONET, SDH)
- Required by various Applications, that may themselves put requirements on the transport network (of any technology)
 - Cellular networks
 - Industrial Automation
 - Smart Grid
 - Positioning
- Time Sync often in the microsecond;
- Frequency sync in parts per billion (ppb)

Cellular network synchronization

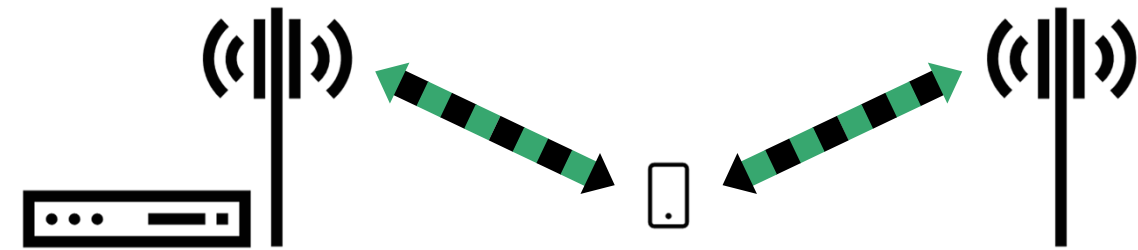

Synchronization for end applications

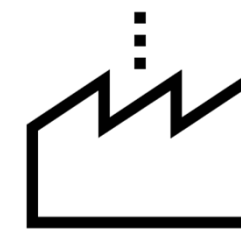

Smart industry

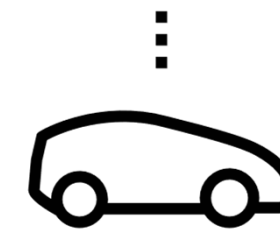

Positioning

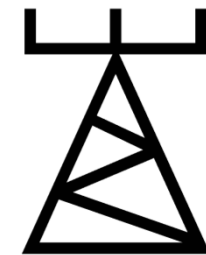

Smart power grids

Time-sensitive networking

Use cases requiring synchronization: 5G

- Coordinated Transmission reception (e.g., Carrier Aggregation):
 - max tolerated relative time difference at the UE (MRTD)

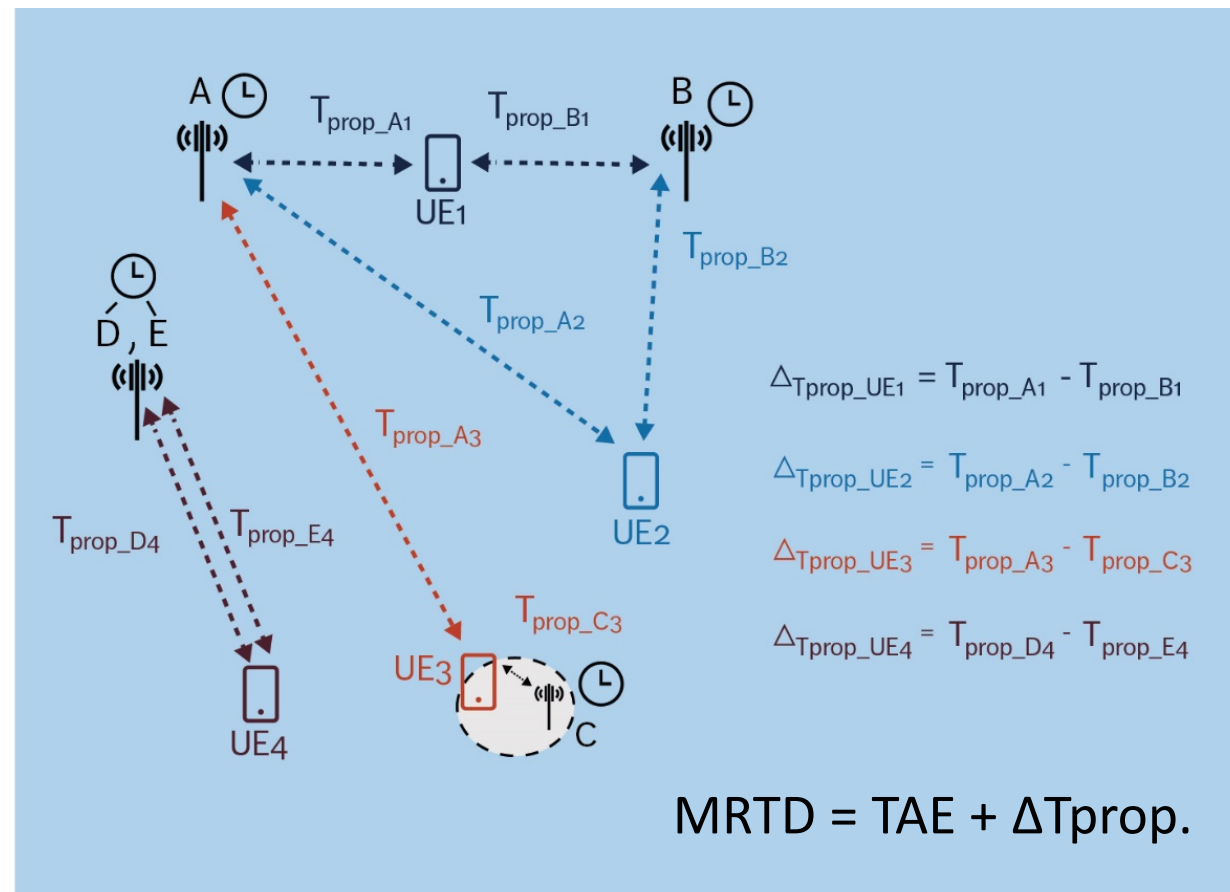

$$\Delta T_{prop_UE1} \text{ and } \Delta T_{prop_UE4} < \Delta T_{prop_UE2} < \Delta T_{prop_UE3}$$

For same delay spread \rightarrow UE1 and UE4 can tolerate larger TAE than UE2 and UE3. For colocated D and E, TAE_{D-E} generally $<$ TAE_{A-B}

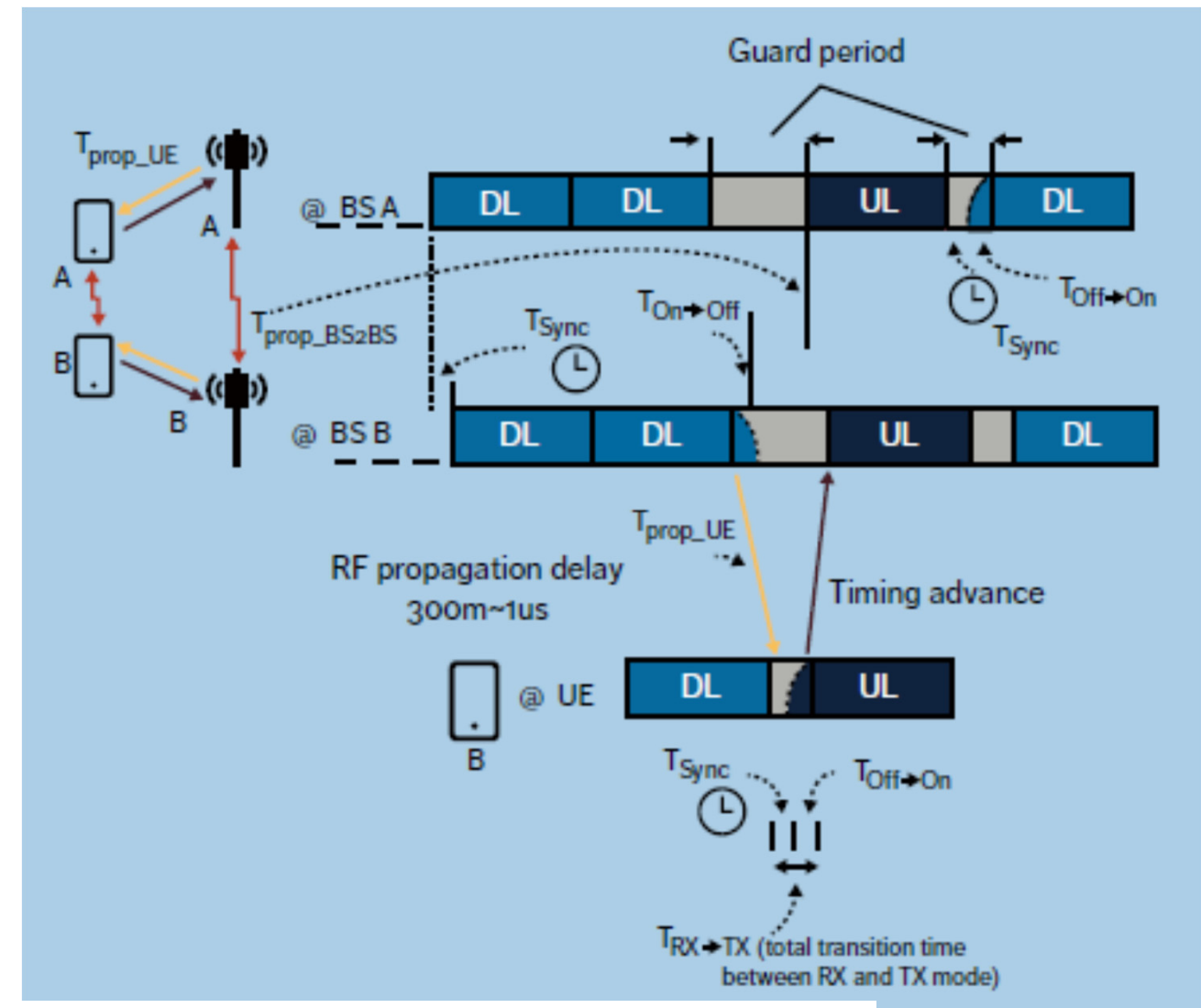

- Time Division Duplex:
 - Synchronization to avoid UL/DL interferences

Use cases requiring synchronization: 5G for TSN

- 5G to support Industrial Automation applications
- Need to meet relevant requirements (to align e.g., production lines, production cells, or machines/functional units)
 - IEEE, Use Cases IEC/IEEE 60802

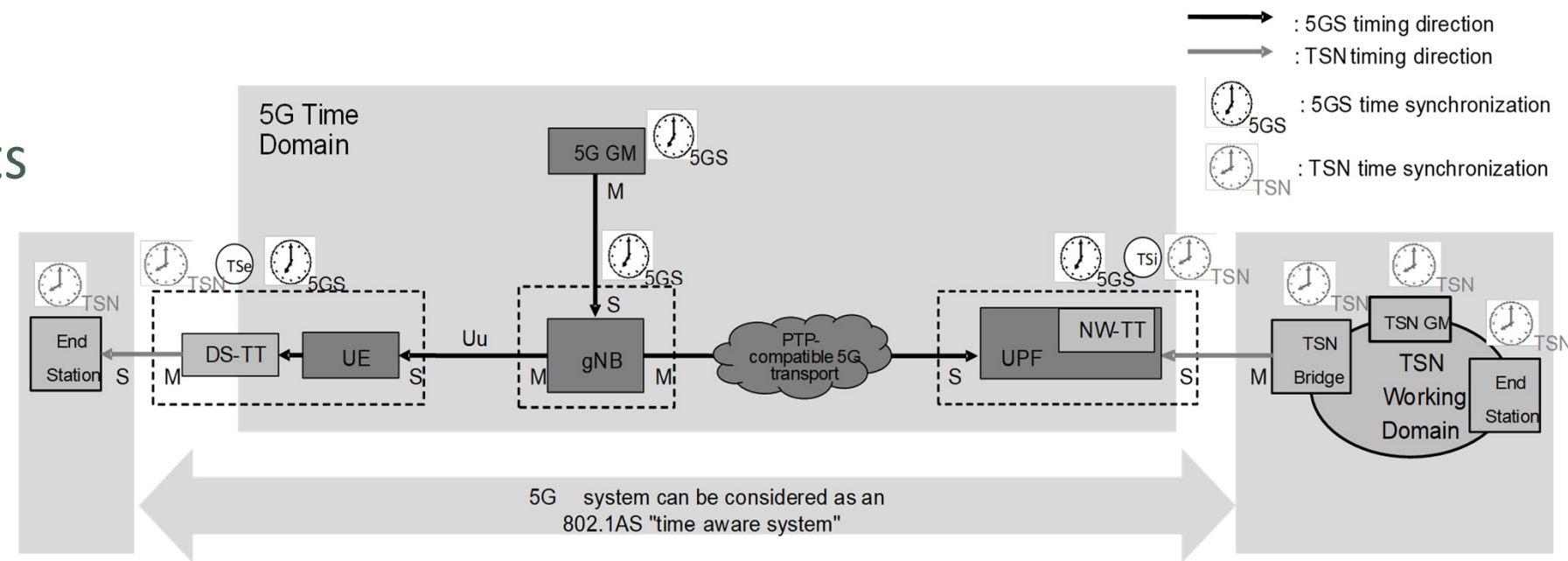

From 3GPP TS 23-501:

5G system is modeled as IEEE Std 802.1AS compliant time aware system for supporting TSN time synchronization

3GPP TS 22.104 The synchronicity budget for the 5G system within the global time domain shall not exceed 900 ns

Synchronization methods in ITU-T G.8271

- Time Sync distributed via PTP

- Distributed PRTC

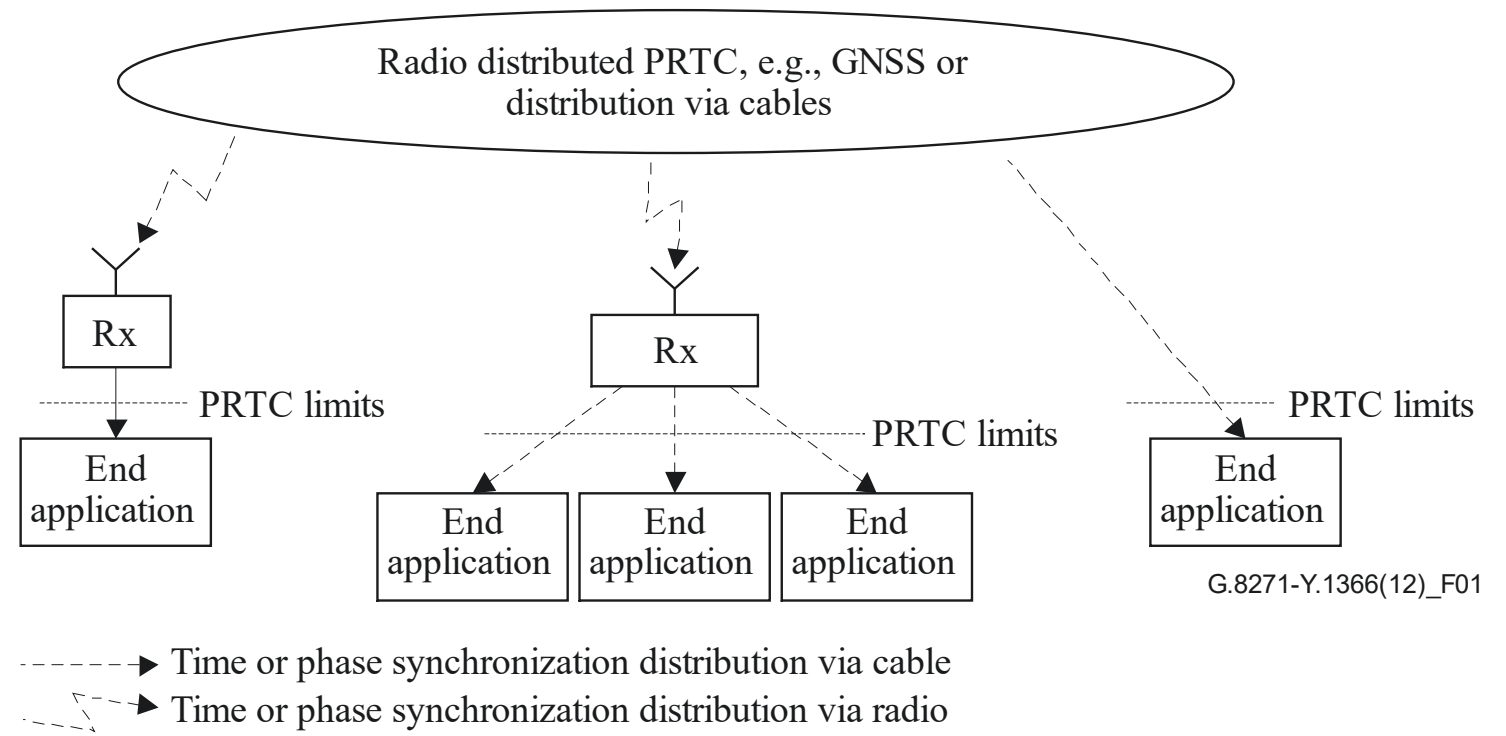
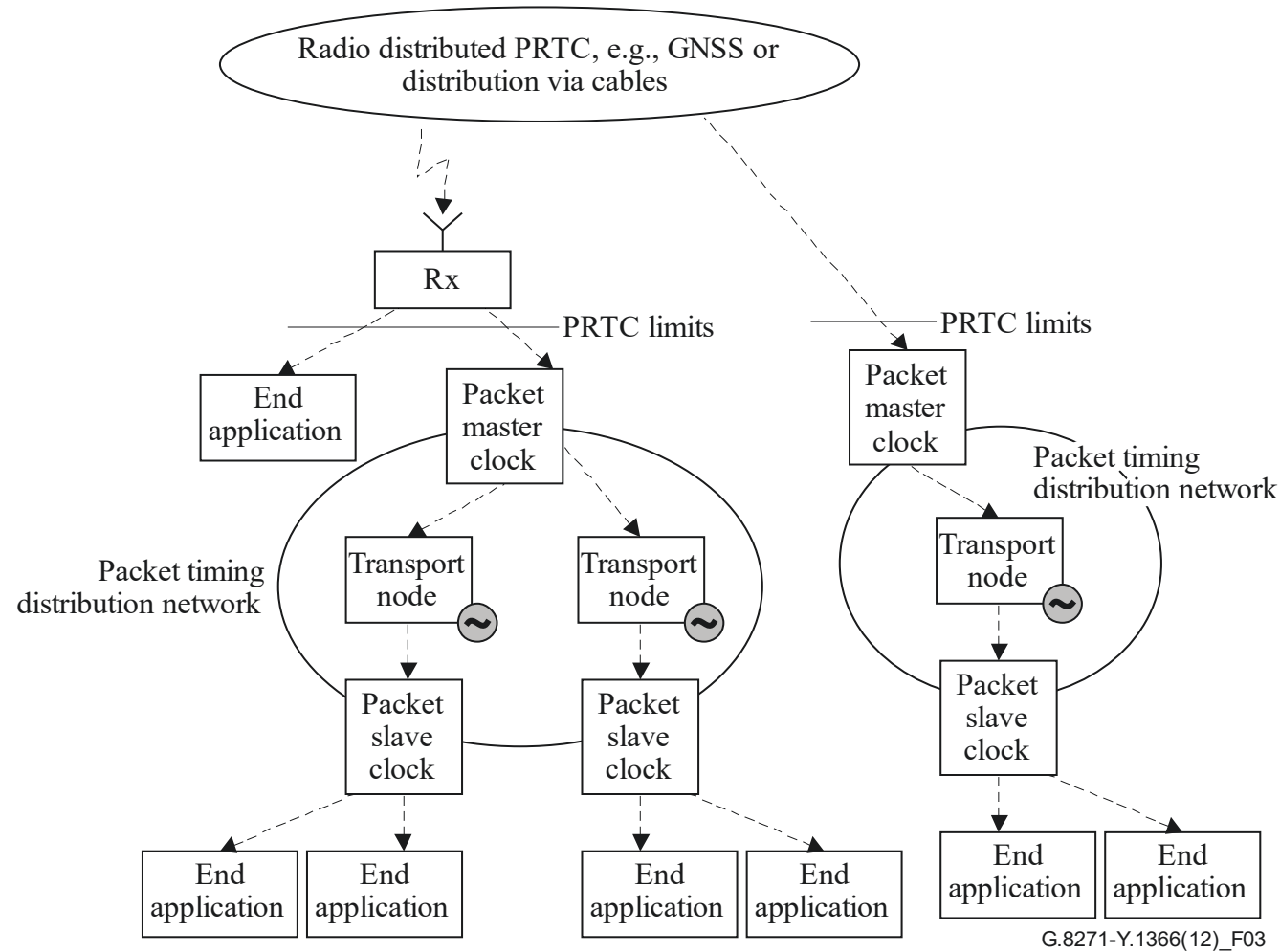

From ITU-T G.8271: Figure 3
Example of time synchronization distributed via packet based methods

- ⊗ T-BC
- > Time or phase synchronization distribution via cable
- - -> Time or phase synchronization distribution via radio

From ITU-T G.8271: Figure 1 – Example of a distributed PRTC synchronization network

Synchronization Architectures

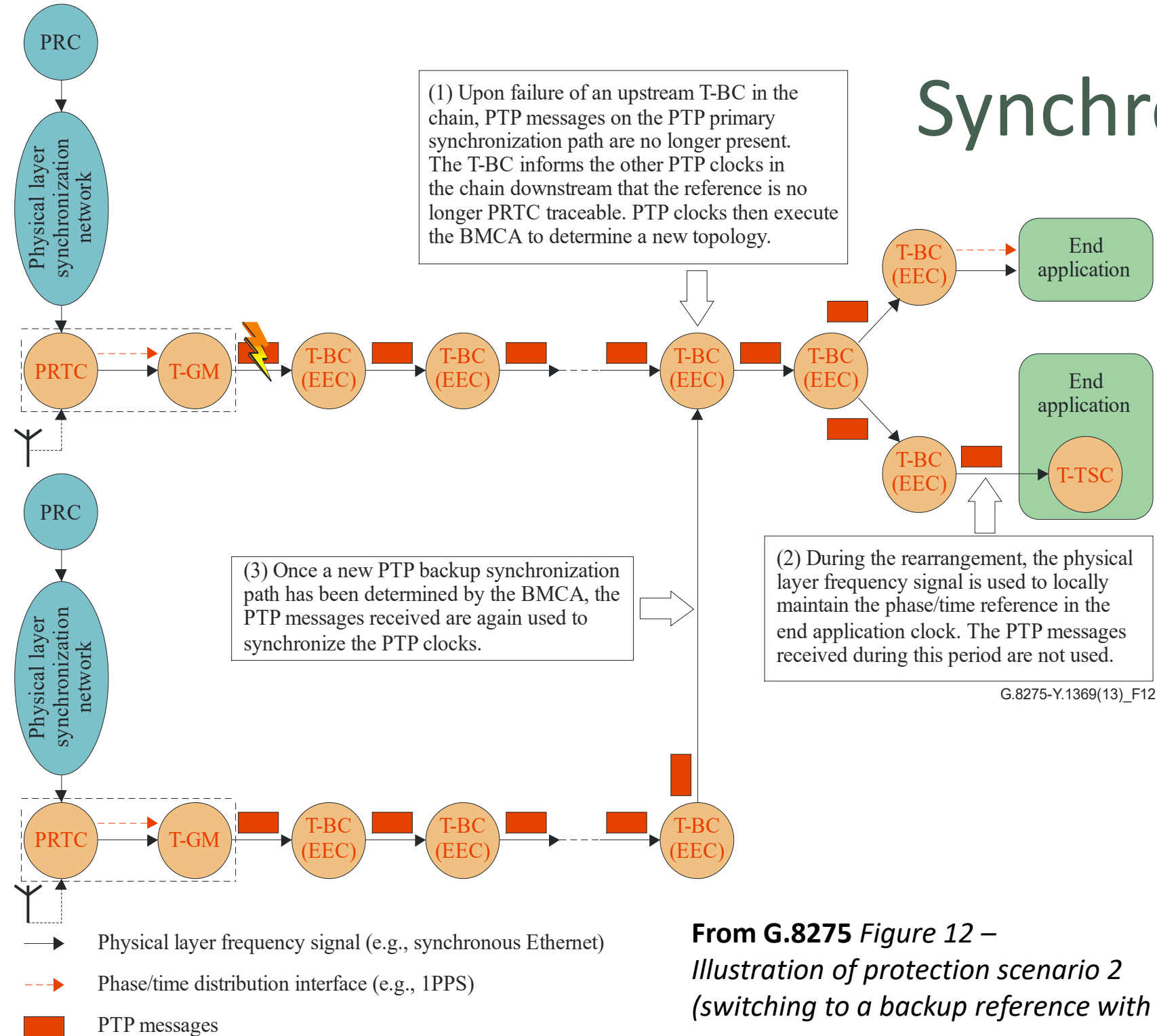

- ITU-T G.8275 specifies the General Architecture for packet-based time sync including related requirements
- Aspects addressed are for instance:
 - Protection scenarios
 - Interworking between PTP profiles

Distribution of Timing – Traditional Telecom Networks

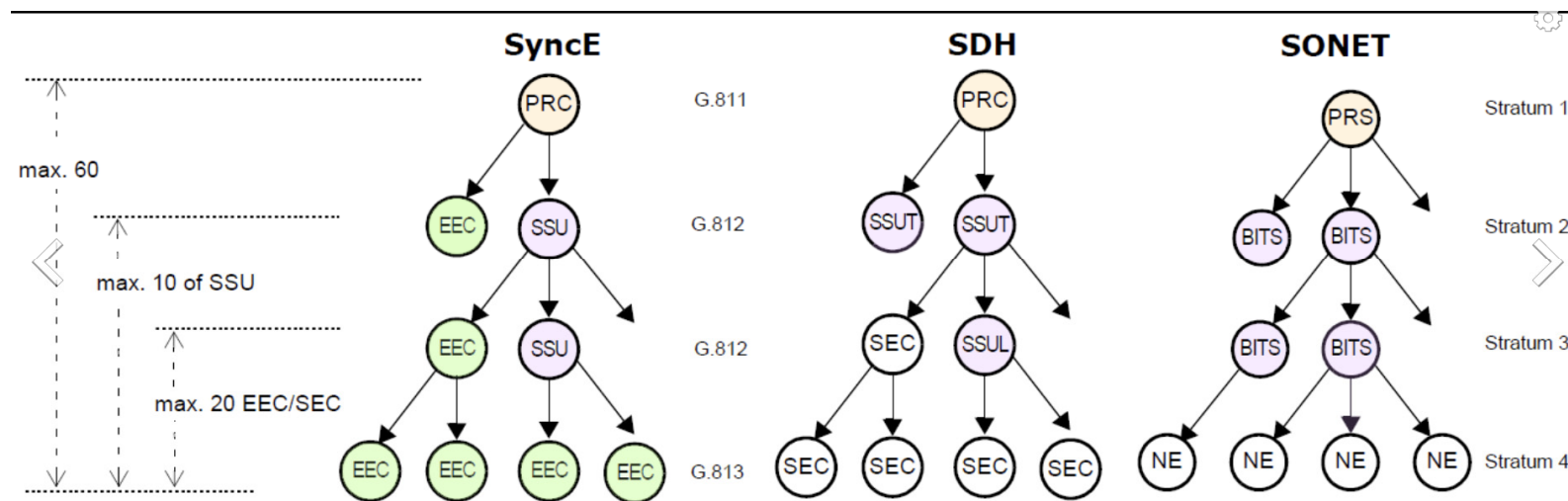

ITU-T G.803 and G.8261 describe the general architecture for physical-layer distribution of (frequency) sync including related requirements for SDH/SONET and Synchronous Ethernet scenarios.

- Traditional Telecom Networks distribute timing in a hierarchical manner
- A “most accurate clock” originates timing and timing references are delivered over the transmission medium allowing the generation of clocks that are aligned with the source
- Similar principles apply to frequency distribution (*aka* physical layer timing), as shown above, as well as time distribution (*aka* packet layer timing such as PTP) shown earlier
- Synchronized clocks utilize PLL methods (*aka* servo methods) for disciplining controlled oscillators and mitigating additive clock noise (jitter/wander/packet-delay-variation)

Clock technologies, modeling, and requirements

Kishan Shenoi and Marc Weiss

kshenoi@qulsar.com, marcweissconsulting@gmail.com

Clock Synchronization Models

Kishan Shenoi

Sync is Fundamentally ...

- Synchronization is fundamentally concerned with the **delay** of a timing signal between clocks
 - Time sync requires accounting for the delay: the better you know the delay, the better the accuracy of synchronization
 - Frequency sync is done over an interval and requires only that the delay remain the same between successive transmissions

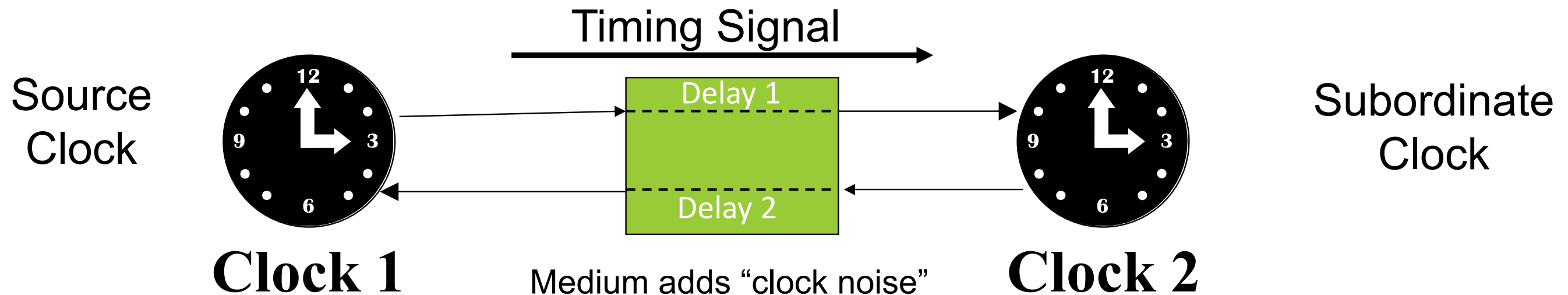

Synchronization Techniques

- A timing signal is a signal that inherently includes the clock properties of the source, allowing the destination to extract a timing reference
- Using this timing reference the destination can construct a (near) replica of the source clock.
- Example: the transmit waveform used to deliver digital information can provide a *frequency reference*.

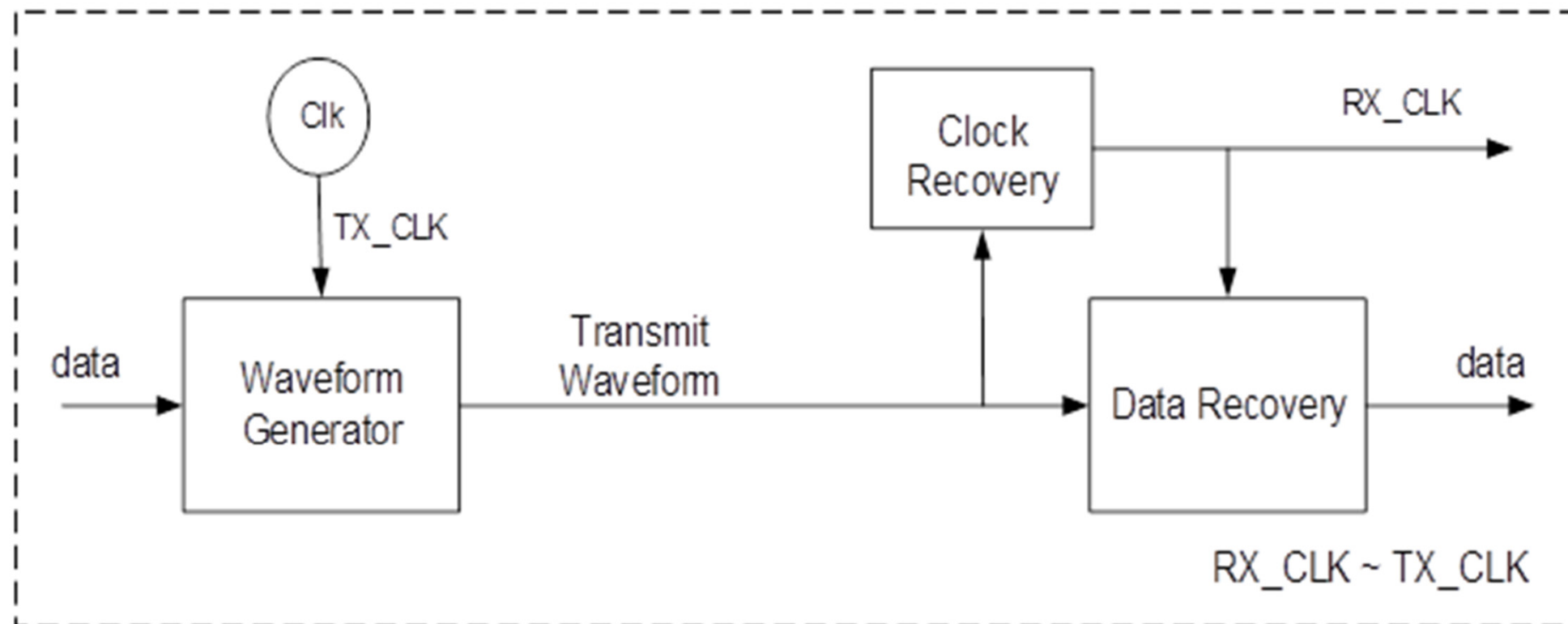

Transfer of frequency – *Timing Signal (one-way)*

- Example: Pulsed transmission provides an edge for each “1”
- Clock Recovery “fills” in the edges... recovered clock \sim transmit clock
- Phase is unknown because of unknown transmission delay (one-way suitable for frequency but not phase/time transfer)
- Jitter in recovered clock can be filtered out (lowpass filter function of a PLL)
- Example: Manchester encoding of data provides a signal transition every bit-time

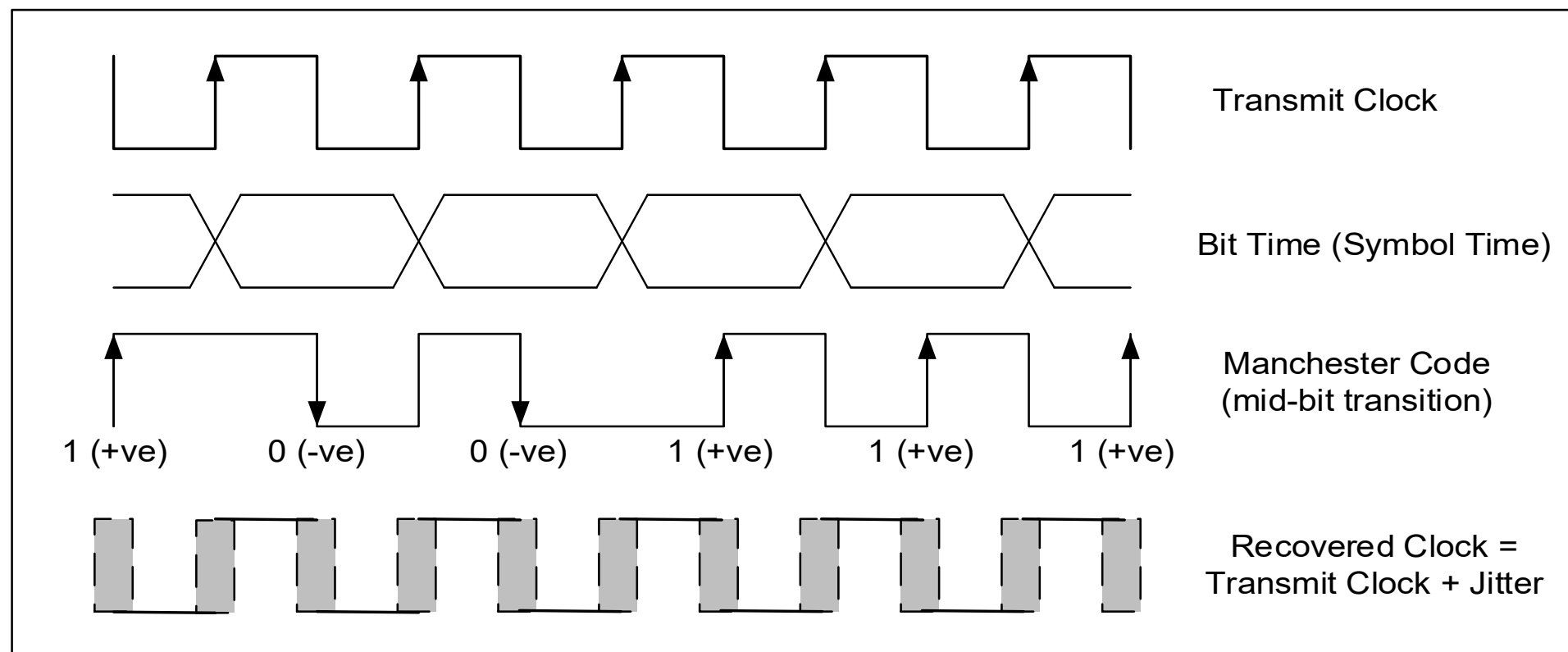

Transfer of Time (e.g. Precision Time Protocol: IEEE 1588™)

- Transfer of time and/or phase requires two-way exchange to determine round-trip delay
- Utilizes time-stamped packets to provide a timing reference
- Transfer quality affected by variable transmission delay and asymmetry
- PTP (aka IEEE 1588™):
 - Master sends *Sync_Message* (with T_1)
 - Slave time-stamps arrival (T_2)
 - Slave sends *Delay_Request*; time-stamps departure (T_3)
 - Master time-stamps arrival (T_4)
 - Master sends *Delay_Response* (with T_4)

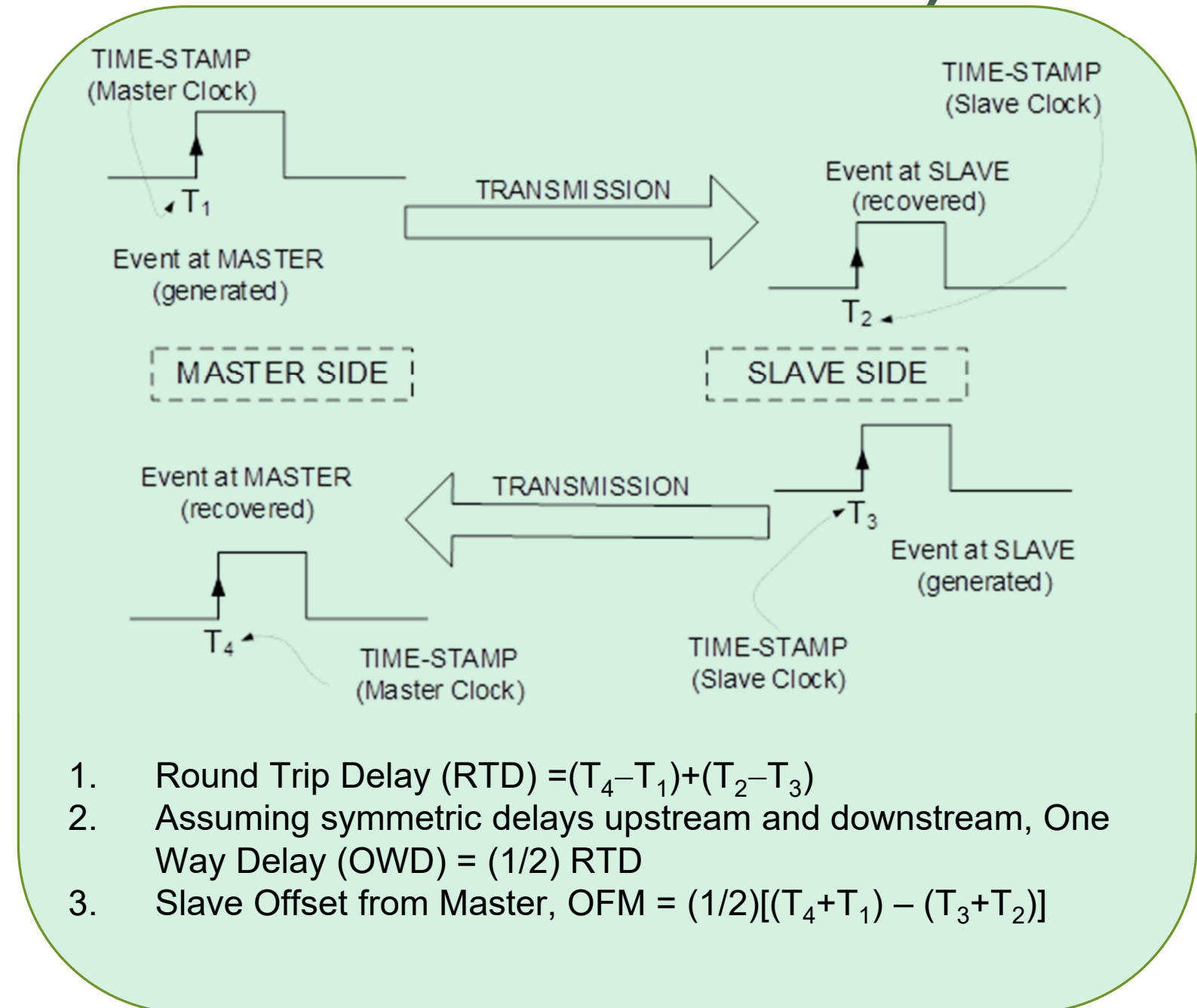

DSP view of a locked loop (Time Domain)

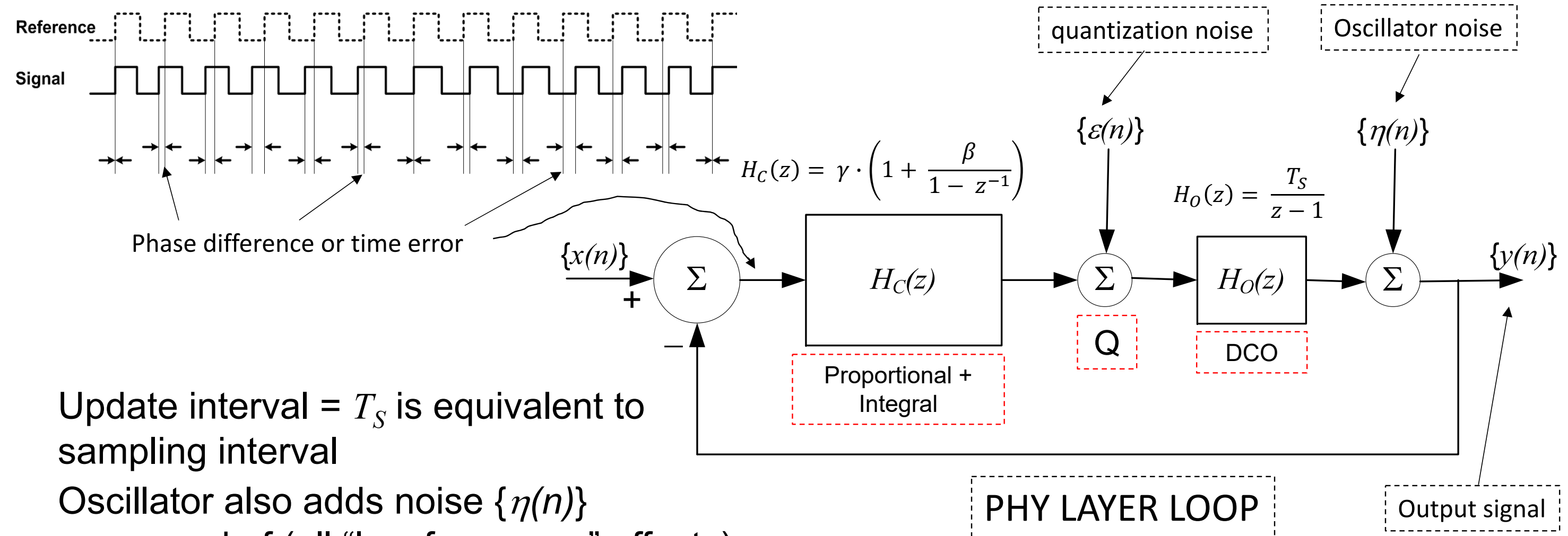

Update interval = T_S is equivalent to sampling interval

Oscillator also adds noise $\{\eta(n)\}$ composed of (all “low-frequency” effects):

- Random component (typically white-FM)
- Effect of aging
- Effect of temperature

PTP Layer Loop is mathematically similar with time error developed from time-stamped packets (“OFM”)

ITU-T Recommendations for Equipment Clocks

- Key items addressed related to timing performance:
 - Input noise limit (jitter & wander) tolerance
 - Output noise (wander) limit, usually as masks for MTIE and TDEV
 - Maximum output time error
 - Bandwidth of PLL or noise transfer characteristics
 - Holdover behavior
 - Transient behavior (e.g., reference switching)
 - Maximum frequency departure
 - Noise generation – output noise when reference inputs are pristine

ITU-T Recommendations for Equipment Clocks

- Principal Recommendations related to timing performance
 - **G.8272** : Primary Reference Time Clock (PRTC)
 - **G.8272.1** : Enhanced Primary Reference Time Clock (ePRTC)
 - **G.8273.2** : Telecom Boundary Clock (T-BC) and Telecom Slave Clock (T-TSC) assuming **full** on-path timing support
 - **G.8273.3** : Telecom Transparent Clocks
 - **G.8273.4** : Telecom Boundary Clock (T-BC) and Telecom Slave Clock (T-TSC) assuming **partial** on-path timing support
 - **G.8263** : Packet-based Equipment Clock (frequency) (assumes **no** on-path timing support)
 - **G.8266** : Telecom grandmaster clocks for frequency synchronization
 - **G.8262** : Synchronous Equipment Slave Clock (*aka* “SEC” and/or “EEC”)
 - **G.8262.1** : Enhanced Synchronous Equipment Slave Clock (*aka* “eSEC” or “eEEC”)

Clocks technologies and Oscillators

Marc Weiss

Block Diagram of Atomic Clock Passive Standard

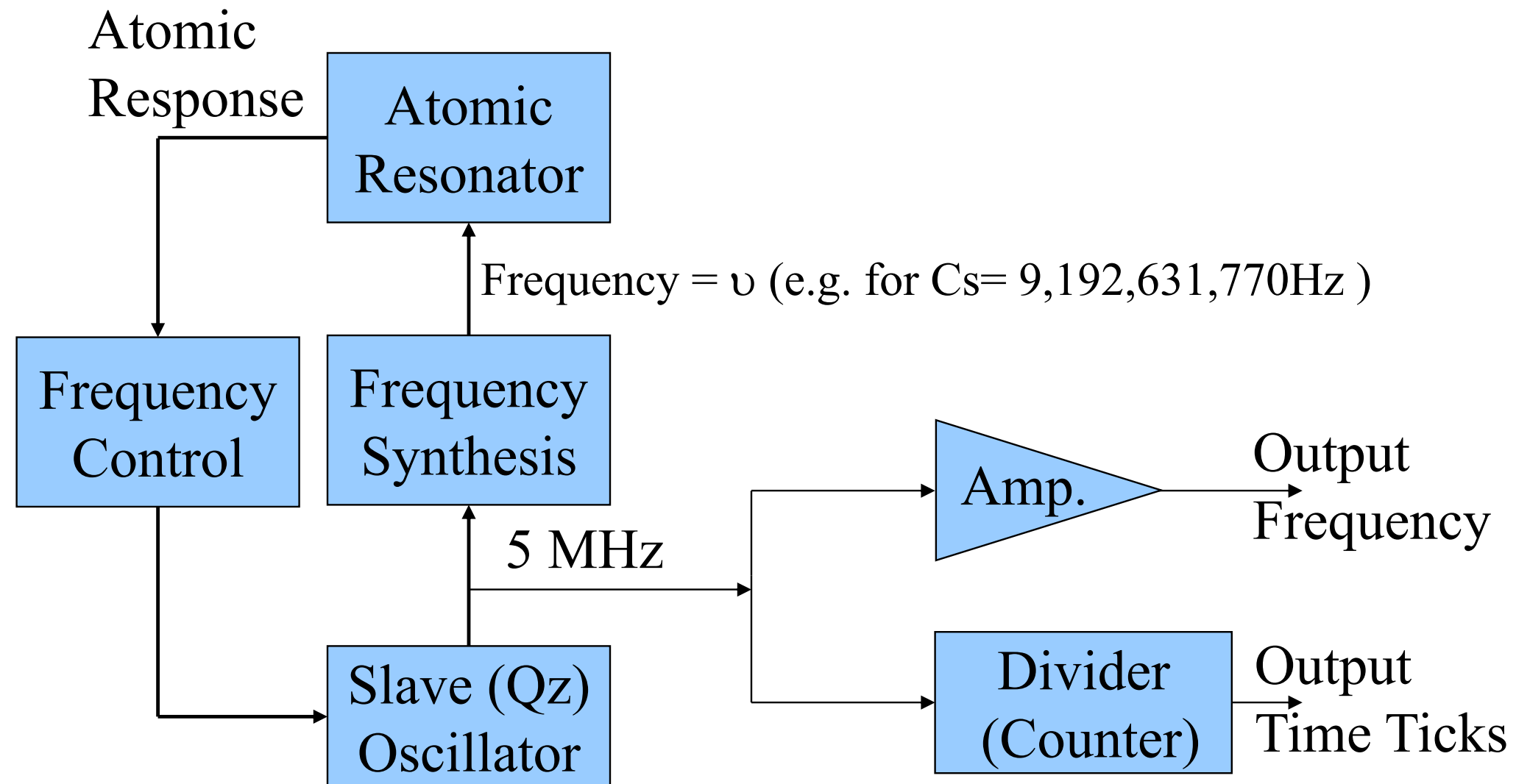

Types of Commercial Atomic Clocks

- Cesium (Cs) thermal beam standard
 - Best long-term frequency stability
- Rubidium (Rb) cell standard
 - Small size, low cost
- Hydrogen (H) maser
 - Best stability at 1 to 10 days (short-term stability)
 - Expensive several \$100K
- Chip Scale Atomic Clock (CSAC)
 - Very small size, low power
- Note that **new generations of clocks** are under development!

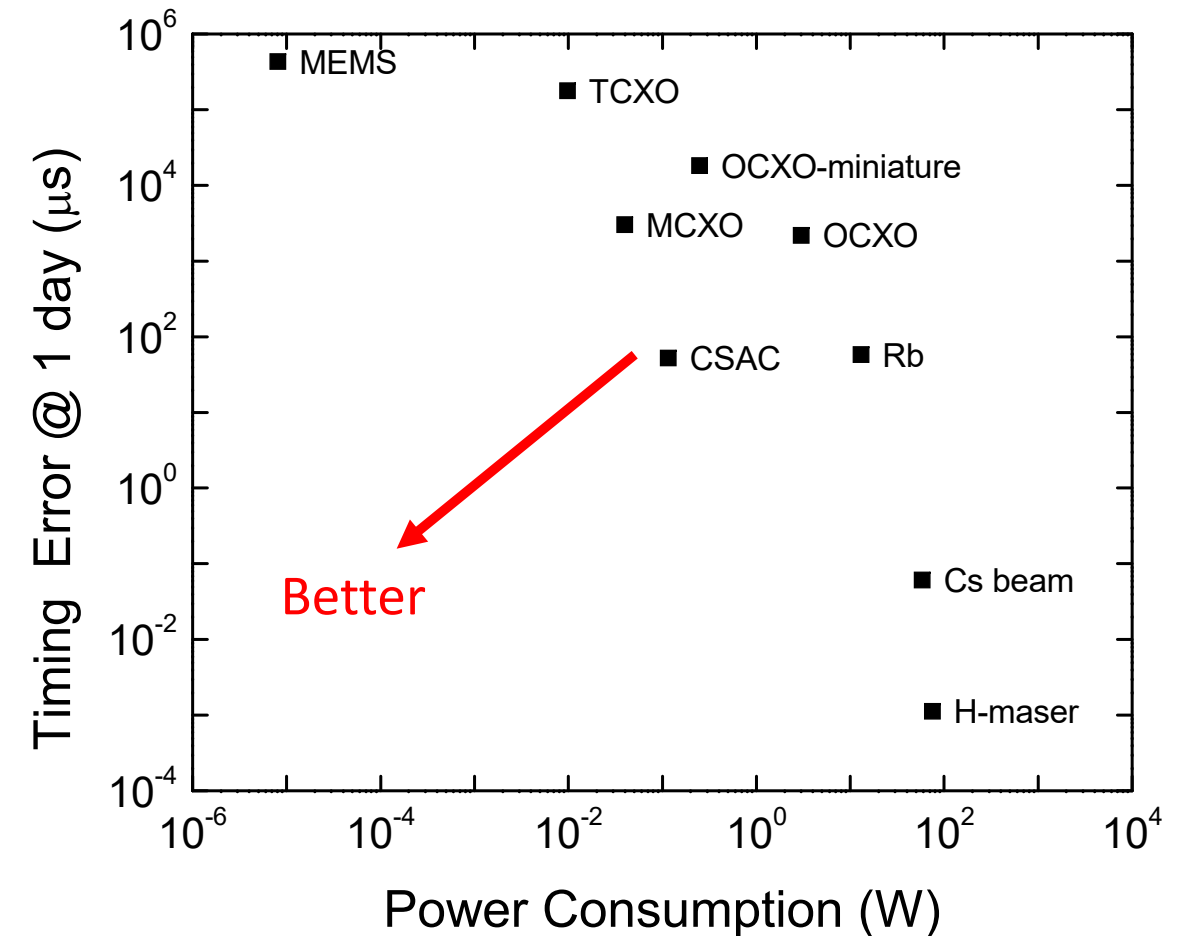

Oscillator Comparison

Technology	Intrinsic Accuracy	Stability (1s)	Stability (floor)	Aging (/day) initial to ultimate	Applications
Cheap Quartz, TCXO	10^{-6}	$\sim 10^{-11}$	$\sim 10^{-11}$	10^{-7} to 10^{-8}	Wristwatch, computer, cell phone, household clock/appliance,...
Hi-quality Quartz, OCXO	10^{-8}	$\sim 10^{-12}$	$\sim 10^{-12}$	10^{-9} to 10^{-11}	Network sync, test equipment, radar, comms, nav,...
Rb Oscillator	$\sim 10^{-9}$	$\sim 10^{-11}$	$\sim 10^{-13}$	10^{-11} to 10^{-13}	Wireless comms infrastructure, lab equipment, GPS, ...
Cesium Beam	$\sim 10^{-13}$	$\sim 10^{-11}$	$\sim 10^{-14}$	nil	Timekeeping, Navigation, GPS, Science, Wireline comms infrastructure,...
Hydrogen Maser	$\sim 10^{-11}$	$\sim 10^{-13}$	$\sim 10^{-15}$	10^{-15} to 10^{-16}	Timekeeping, Radio astronomy, Science,...

Oscillator Comparison (continued)

Technology	Size	Weight	Power	World Market	Cost
Cheap Quartz, TCXO	$\approx 1 \text{ cm}^3$	$\approx 10 \text{ g}$	$\approx 10 \text{ mW}$	$\approx 10^9\text{s/year}$	$\approx \$1\text{s}$
Hi-quality Quartz, OCXO	$\approx 50 \text{ cm}^3$	$\approx 500 \text{ g}$	$\approx 10 \text{ W}$	$\approx 10\text{Ks/year}$	$\approx \$100\text{s}$
Rb Oscillator	$\approx 200 \text{ cm}^3$	$\approx 500 \text{ g}$	$\approx 10 \text{ W}$	$\approx 10\text{Ks/year}$	$\approx \$1000\text{s}$
Cesium Beam	$\approx 30,000 \text{ cm}^3$	$\approx 20 \text{ kg}$	$\approx 50 \text{ W}$	$\approx 100\text{s/year}$	$\approx \$10\text{Ks}$
Hydrogen Maser	$\approx 1 \text{ m}^3$	$\approx 200 \text{ kg}$	$\approx 100 \text{ W}$	$\approx 10\text{s/year}$	$\approx \$100\text{Ks}$

Holding a Microsecond after Loss of Sync (circa 2020)

	Temperature Compensated Crystal Oscillator (TCXO)	Oven Controlled Crystal Oscillator (OCXO)	Chip Scale Atomic Clock (CSAC)	Rb Oscillator (5E-12/mo. aging)	Cs Beam-Tube Oscillator
Range of times to hold a microsecond	10 minutes – 1 hour	1 – 12 hours	3-15 hours	8 hours – 3 days	10-300 days
Cost Range	\$5-20	\$50-500	\$1.5K-3K	\$500-1500	\$20K - \$50K

IEEE 1588 PTP Telecom Profiles

Lee Cosart and Silvana Rodrigues

Lee.Cosart@microchip.com , silvana.rodrigues@huawei.com

Introduction on Profiles

Lee Cosart

Contents

- Profile concept
- ITU-T Q13/15 Telecom Profiles overview
- ITU-T G.8275.1 Profile
- ITU-T G.8275.2 Profile

The concept of Profile

- A **profile** is a subset of required **options**, prohibited options, and the ranges and defaults of configurable attributes
- e.g. for Telecom: update rate, unicast/multicast, etc.
- PTP profiles are created to allow organizations to specify selections of attribute values and optional features of PTP that, when using the same transport protocol, **inter-works** and achieve a **performance** that meets the requirements of a particular application
- Telecom Profiles: ITU-T G.8265.1, G.8275.1, G.8275.2
- Other (non-Telecom) profiles:
 - IEEE C37.238 (Standard Profile for Use of IEEE 1588 Precision Time Protocol in Power System Applications,)
 - IEEE 802.1AS (Timing and Synchronization for Time-Sensitive Applications in Bridged Local Area Networks)

ITU-T Q13/15 Profiles, Clocks and Migration of the Network

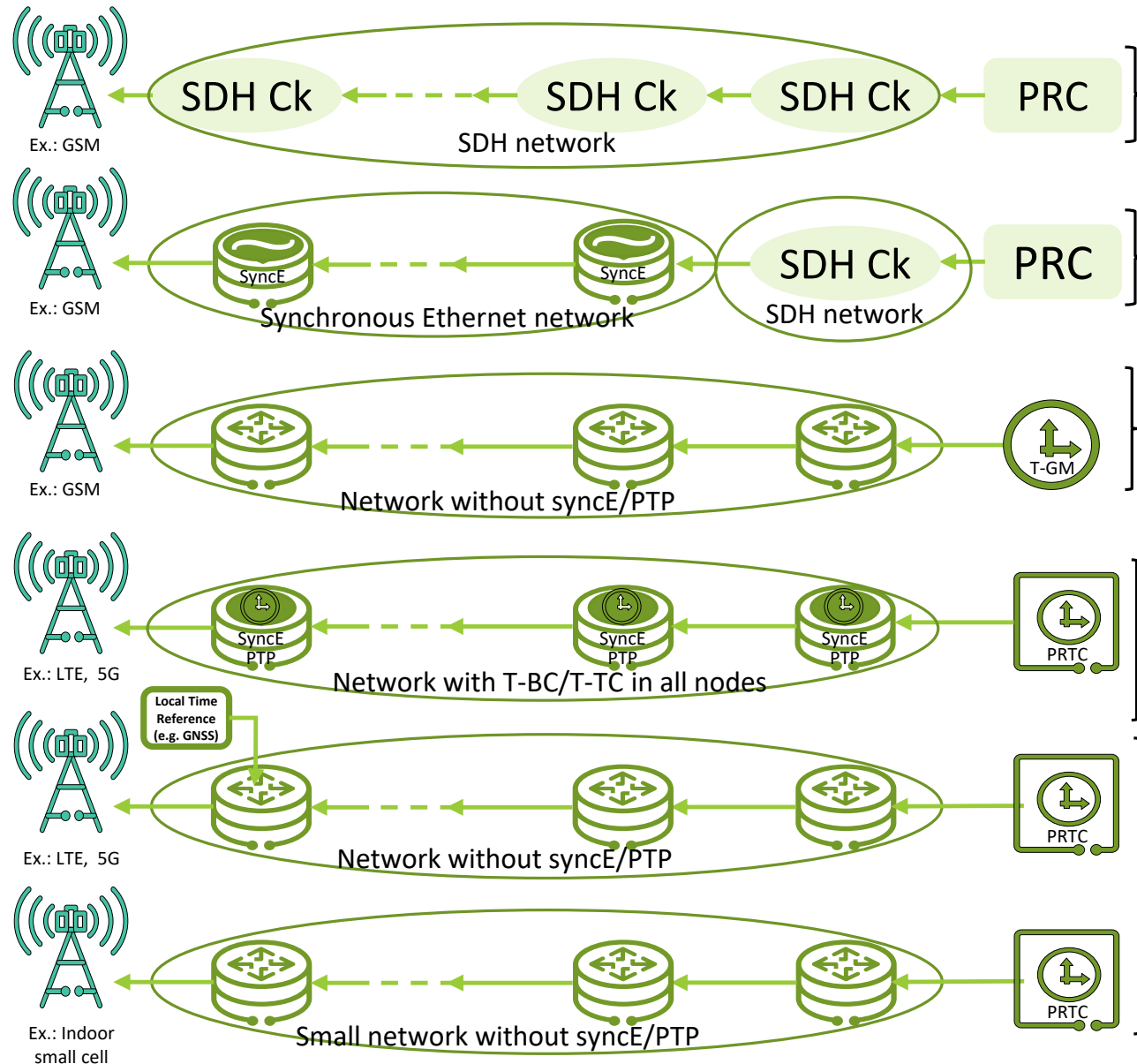

ITU-T G.813, G.811, G.812 specifies clocks used in the SDH Network

ITU-T G.8262 specifies synchronous clocks, including Synchronous Ethernet (SyncE), that are compatible with SDH clocks defined in G.813 and G.812

ITU-T G.8265.1 profile was targeted for applications that need frequency synchronization suitable for earlier deployment scenarios that only needed frequency when there was no syncE and no IEEE 1588 support in the equipment. ITU-T G.8263 specifies the end clock.

ITU-T G.8275.1 profile was targeted for applications that need accurate phase/time synchronization required due to increasing need for time sync in Telecom. It was enabled by upgrades done in the network to support T-BCs and/or T-TCs in every node of the network. Enhanced synchronous clocks (e.g., eSyncE) are specified in G.8262.1 for tighter clock accuracy. ITU-T G.8273.2 specifies T-BC/T-TSC and G.8273.3 specifies T-TC.

ITU-T G.8275.2 profile was targeted for applications that need accurate phase/time synchronization, but the network is not able to provide full time support (no T-BCs/T-TCs) due to legacy equipment or in the case of leased line. ITU-T G.8273.4 specifies the clocks.

Appendix III of ITU-T G.8275 provides generic interworking function used to connect network segments that are running different profiles

ITU-T G.8275.1 and G.8275.2 Profiles

Silvana Rodrigues

Time/phase Synchronization Architecture with full timing support from Network

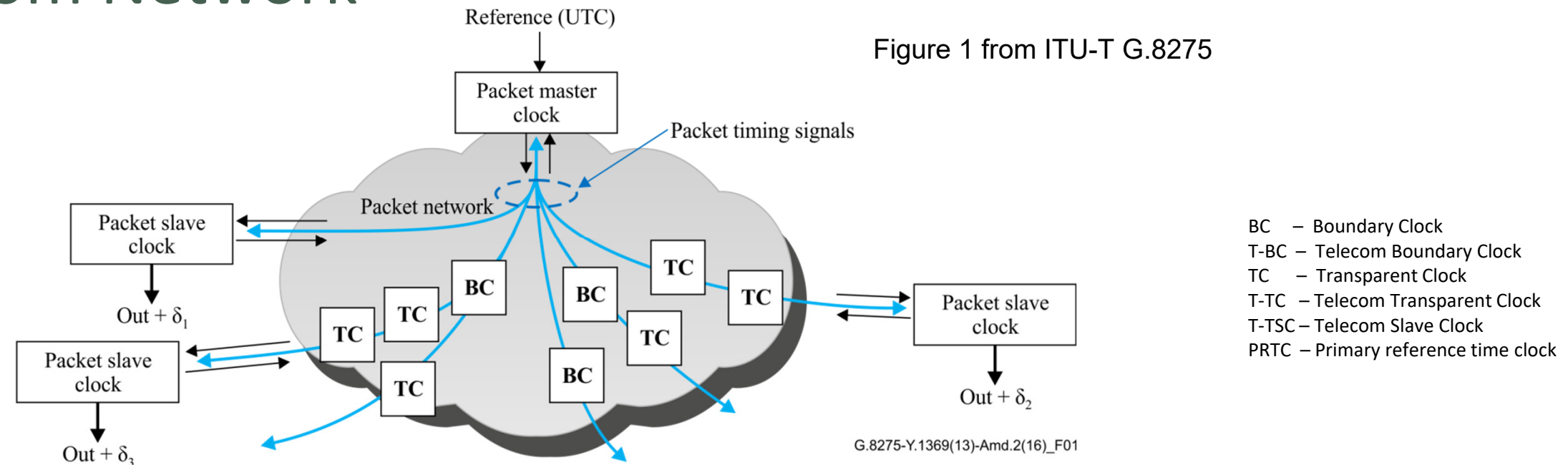

- General network topology for time/phase distribution from a packet master clock PRTC to a synchronous Equipment clock
- The synchronization flow is from the master to end equipment nodes, although the timing messages will flow in both directions
- Several ITU-T Recommendations has been developed to support accurate phase/time synchronization
 - **G.8275** (Architecture), **G.8275.1** (PTP telecom profile), **G.8271** (Network Requirements), **G.8271.1** (Network limits), **G.8272** (PRTC), **G.8272.1** (enhanced PRTC), **G.8273** (Framework of clocks), **G.8273.2** (T-BC and T-TSC), **G.8273.3** (T-TC)

ITU-T G.8271.1 PTP network architecture

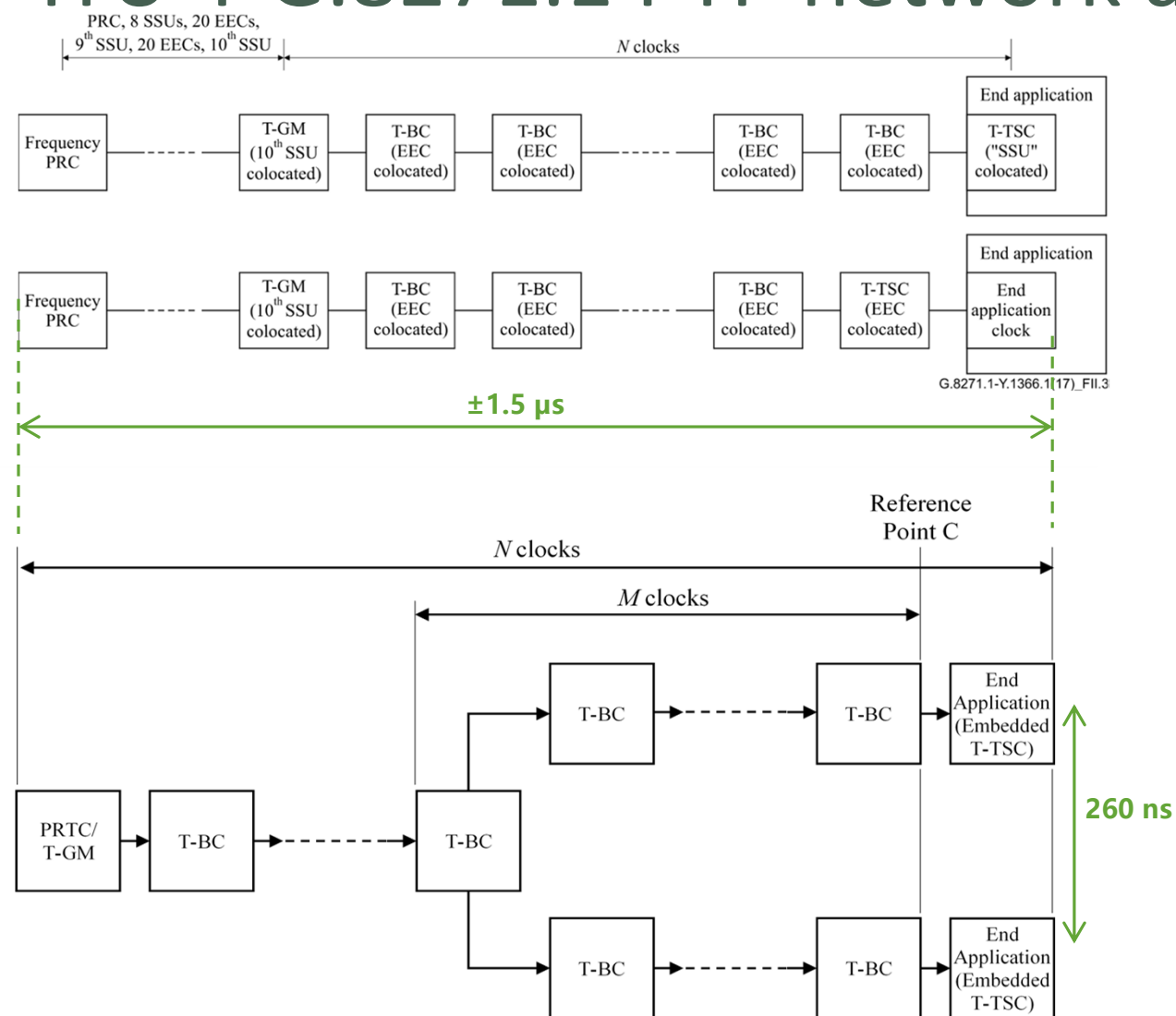

PRC = Primary Reference Clock
 PRTC = Primary Reference Time Clock
 T-GM = Telecom Grand Master
 T-BC = Telecom Boundary Clock
 T-TC = Telecom Transparent Clock
 T-TSC – Telecom Slave Clock

- G.8273.2 and G.8273.3 define several classes of T-BCs and T-TCs to be used in G.8271.1 architecture. Reference chains with class A and B have been fully studied for telecom backhaul
 - For shorter chain $N=12$ (uses T-BC/T-TC class A)
 - For longer chain $N=22$ (uses T-BC/T-TC class B)
- G.8275.1 profile is used in this architecture
- Guidelines for network dimensioning for telecom fronthaul
- Fronthaul assumes the use of T-BC Class C (enhanced Synchronous Ethernet required) or T-BC class B
- Short clock chain ($M \leq 4$ with class C and $M=1$ for class B)

T-BC/T-TC	cTE	dTE (MTIE)	max TE	dTE (High-Pass filtered)
Class A (with SyncE)	+/-50 ns	40 ns	100 ns	70 ns
Class B (with SyncE)	+/-20 ns	40 ns	70 ns	70 ns
Class C (with eSyncE)	+/-10 ns	10 ns	30 ns (T-BC) Under Study for T-TC	Under Study
Class D (with eSyncE) Only T-BC	Under Study	Under Study	5 ns *	Under Study

*measured with a first order filter of 0.1Hz bandwidth

ITU-T G.8275.1 Modes and Options

- The default domain is 24 and the range is 24 to 43
- Supports Ordinary clock (OC), Boundary Clock (BC) and Transparent Clock (TC)
- Supports both one-step and two-step clocks
- Supports only Multicast for PTP over IEEE 802.3/Ethernet
 - Both the non-forwardable multicast address 01-80-C2-00-00-0E and the forwardable multicast address 01-1B-19-00-00-00 are supported
- PTP Mappings
 - Transport of PTP over IEEE 802.3/Ethernet (IEEE Std 1588TM-2008 Annex F)
 - Transport of PTP over OTN (based on G.7041 and G.709)
- Path delay measurement based on delay request/delay response mechanism
- PTP Messages
 - Sync messages – nominal rate: 16 packets-per-second
 - Delay_Req/Delay_Resp messages – nominal rate: 16 packets-per-second
 - Announce messages – nominal rate: 8 packets-per-second
- Alternate BMCA – based on IEEE 1588 default BMCA
 - It allows two main approaches to set up the synchronization network: automatic topology establishment and manual network topology (use of the localPriority per PTP port)

ITU-T G.8275.1 – Optional Features

- Packet Timing Signal Fail
 - PTSF-lossSync – indicates the lack of reception of PTP timing messages
 - PTSF-unusable – indicates unusable PTP timing signal (e.g, excessive noise or abnormal timestamps)
 - PTSF-syncUncertain – indicates the receipt of synchronizationUncertain flag in the Announce message set to true from an upstream clock
- Virtual PTP port on a PTP clock
 - Allows the inclusion of a unidirectional phase/time interface on a PTP clock
- Path trace option as per clause 16.2 of IEEE Std 1588TM-2008
- Synchronization uncertain indication
 - Based on the synchronizationUncertain flag received in the Announce message
- Use of stepsRemoved to limit reference chain
 - Can be used to limit the length of the clock chain
 - Can be used to identify rogue frames
- Monitoring a PTP MASTER port by a PTP PASSIVE port
 - Allows a PTP port in PASSIVE state to exchange PTP messages with a PTP Master port for monitoring purposes only

Time/phase Synchronization Architecture without PTP timing support from Network

APTS

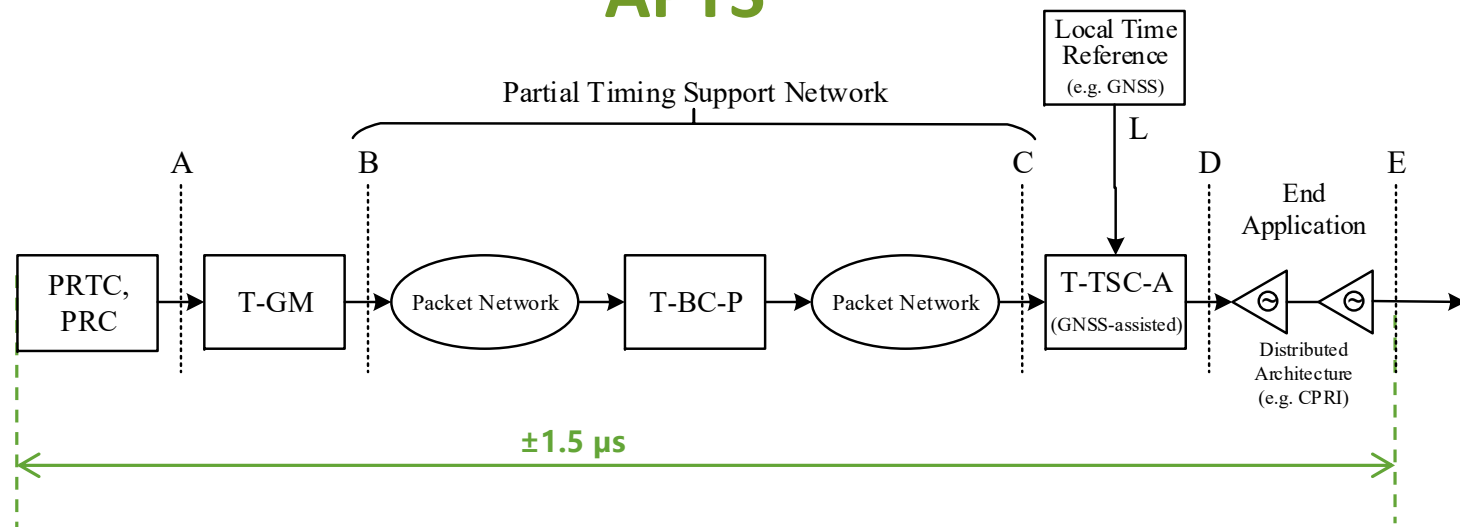

PTS

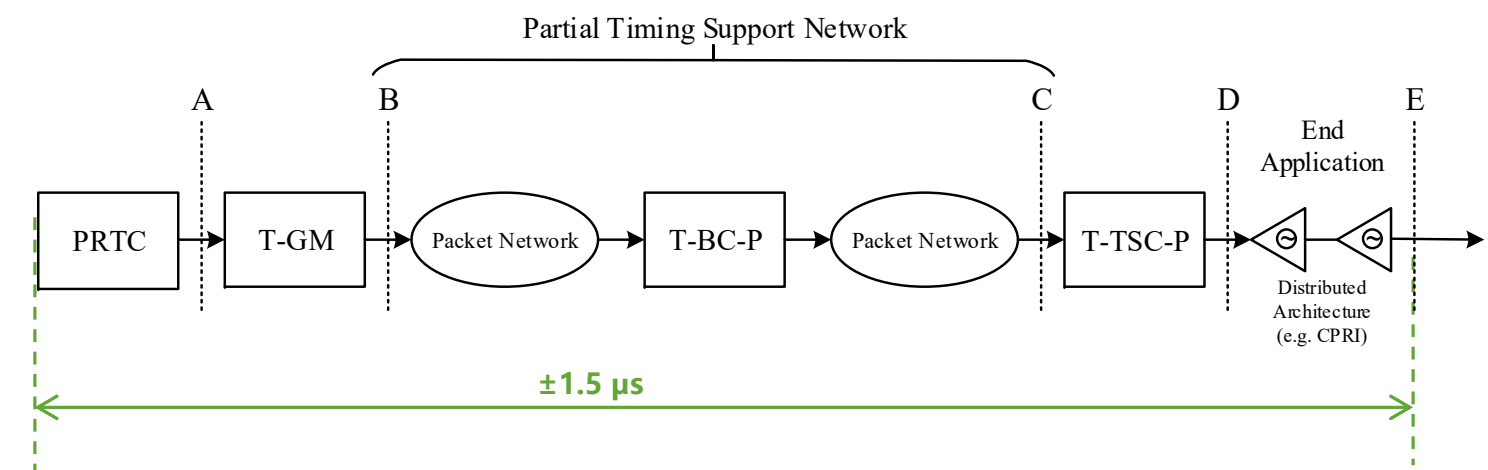

Figures I.1 and I.2 from ITU-T G.8275.2 latest draft

- Assisted Partial Timing Support (APTS) – GNSS is co-located with the T-TSC-A
 - PTP is used as a backup for GNSS failures
- Partial Timing Support (PTS) – without the GNSS co-located with T-TSC-P
 - Only PTP is used for timing
- Related ITU-T recommendations (G.827x) :
 - **G.8275** (Architecture), **G.8275.2** (PTP Telecom Profile); **G.8271** (Network Requirements), **G.8271.2** (Network), **G.8272** (PRTC), **G.8272.1** (enhanced PRTC), **G.8273** (Framework of clocks), **G.8273.4** (T-BC-A, T-BC-P, T-TSC-A, T-TSC-P)

GNSS= Global Navigation Satellite System
 T-BC-A – Telecom Boundary Clock – Assisted
 T-TSC-A – Telecom Time Slave Clock – Assisted
 T-TSC-P – Telecom Boundary Clock – Partial support
 T-TSC-P – Telecom Time Slave Clock – Partial support

ITU-T G.8275.2 Modes and Options

- The default domain is 44 and the range is 44 to 63
- Supports Ordinary clock (OC) and Boundary Clock (BC)
- Supports both one-step and two-step clocks
- Supports only unicast for PTP over IP
- PTP Mappings
 - Transport of PTP over User Datagram Protocol over Internet Protocol Version 4 (IEEE Std 1588™-2008 Annex D)
 - Transport of PTP over User Datagram Protocol over Internet Protocol Version 6 (IEEE Std 1588™-2008 Annex E)
- Path delay measurement based on delay request/delay response mechanism
- PTP Messages
 - Sync messages – minimum of 1 packet-per-second and a maximum of 128 packets-per-second
 - Delay_Req/Delay_Resp messages – minimum of 1 packet-per-second and a maximum of 128 packets-per-second
 - Announce messages – minimum of 1 packet-per-second and a maximum of 8 packets-per-second
 - Signalling messages – no rate is specified
- Supports Unicast message negotiation in accordance with clause 16.1 of IEEE Std 1588™-2008
- Alternate BMCA – based on IEEE 1588 default BMCA
 - It allows two main approaches to set up the synchronization network: automatic topology establishment and manual network topology (use of the localPriority per PTP port)

ITU-T G.8275.2 – Optional Features

- Packet Timing Signal Fail
 - PTSF-lossSync – indicates the lack of reception of PTP timing messages
 - PTSF-unusable – indicates unusable PTP timing signal (e.g., excessive noise or abnormal timestamps)
 - PTSF-syncUncertain – indicates the receipt of synchronizationUncertain flag in the Announce message set to true from an upstream clock
- Virtual PTP port on a PTP clock
 - Allows the inclusion of a unidirectional phase/time interface on a PTP clock
- PTP interface rate
 - TLV to exchange information about PTP interface rate between a slave port and a master port. This allows asymmetry due to different port rates to be compensated at the slave port
- Synchronization uncertain indication
 - Based on the synchronizationUncertain flag received in the Announce message

ITU-T G.8265.1, G.8275.1, G.8275.2 - PTP Options and Configurable Attributes

PTP Options/Attributes	G.8265.1	G.8275.1	G.8275.2
Domain Number	default : 4, range: {4-23}	default : 24, range: {24-43}	default : 44, range: {44-63}
Types of Clocks	Ordinary clocks (i.e. Grandmasters, slave-only clocks)	<ul style="list-style-type: none"> - Ordinary clocks (i.e. Grandmasters, slave-only clocks) - Boundary clocks - End-to-end transparent clocks 	<ul style="list-style-type: none"> - Ordinary clocks (i.e. Grandmasters, slave-only clocks) - Boundary clocks
Time Transfer	<ul style="list-style-type: none"> - One-way - Two-way 	<ul style="list-style-type: none"> - Two-way 	<ul style="list-style-type: none"> - Two-way
Type of clocks	One-step and two-step	One-step and two-step	One-step and two-step
Transport Mode	Unicast <ul style="list-style-type: none"> - IEEE1588-2008 Annex D IPv4/UDP stack - IEEE1588-2008 Annex E IPv6/UDP stack 	Multicast <ul style="list-style-type: none"> - IEEE1588-2008 Annex F - Transport of PTP over OTN (based on G.7041 and G.709) 	Unicast <ul style="list-style-type: none"> - IEEE1588-2008 Annex D IPv4/UDP stack - IEEE1588-2008 Annex E IPv6/UDP stack
Path delay measurement	delay request/delay response mechanism	delay request/delay response mechanism	delay request/delay response mechanism
PTP Message rate (packets/s)	Sync /Follow-up – min rate:1/16, max rate: 128 Delay_Request/Delay_Response – min rate:1/16, max rate: 128 Announce – min rate:1/16, max rate: 128	Sync /Follow-up – fixed rate of 16 Delay_Request/Delay_Response – fixed rate of 16 Announce – fixed rate of 8	Sync /Follow-up – min rate:1, max rate: 128 Delay_Request/Delay_Response – min rate:1, max rate: 128 Announce – min rate:1, max rate: 128 Signaling messages – no rate is specified
BMCA	Alternate BMCA	alternate BMCA based on the IEEE 1588 default BMCA	alternate BMCA based on the IEEE 1588 default BMCA

References

ITU-T Recommendations (Packet Sync - Frequency)

- All ITU-T Published Recommendations can be downloaded from: <http://www.itu.int/rec/T-REC-G/e>
- ITU-T Recommendation G.8260, Definitions and terminology for synchronization in packet networks
- ITU T Recommendation G.8261, Timing and synchronization aspects in packet networks.
- Recommendation ITU-T G.8261.1, Packet Delay Variation Network Limits applicable to Packet Based Methods (Frequency Synchronization)
- ITU T Recommendation G.8262, Timing characteristics of Synchronous Equipment slave clock.
- ITU T Recommendation G.8262.1, Timing characteristics of an enhanced synchronous equipment slave clock
- ITU-T Recommendation G.8263, Timing Characteristics of Packet based Equipment Clocks
- ITU T Recommendation G.8264, Distribution of timing through packet networks
- ITU-T Recommendation G.8265, Architecture and requirements for packet based frequency delivery
- ITU-T Recommendation G.8265.1, Precision time protocol telecom profile for frequency synchronization
- ITU T Recommendation G.8266, Timing characteristics of telecom grandmaster clocks for frequency synchronization

ITU-T Recommendations (Packet Sync – Phase/Time)

- All ITU-T Published Recommendations can be downloaded from: <http://www.itu.int/rec/T-REC-G/e>
- ITU T Recommendation G.8271, Time and phase synchronization aspects of packet networks
- ITU T Recommendation G.8271.1, Network limits for time synchronization in packet networks with full timing support from the network
- ITU T Recommendation G.8271.2, Network limits for time synchronization in packet networks with partial timing support from the network
- ITU T Recommendation G.8272, Timing characteristics of Primary reference time clock
- ITU T Recommendation G.8272.1, Timing characteristics of enhanced primary reference time clock
- ITU T Recommendation G.8273, Framework of phase and time clocks
- ITU T Recommendation G.8273.2, Timing characteristics of telecom boundary clocks and telecom time slave clocks for use with full timing support from the network
- ITU T Recommendation G.8273.3, Timing characteristics of telecom transparent clocks for use with full timing support from the network
- ITU T Recommendation G.8273.4, Timing characteristics of partial timing support telecom boundary clocks and telecom time slave clocks
- ITU T Recommendation G.8275, Architecture and requirements for packet-based time and phase delivery
- ITU T Recommendation G.8275.1, Precision time protocol telecom profile for phase/time synchronization with full timing support from the network
- ITU T Recommendation G.8275.2, Precision time Protocol Telecom Profile for time/phase synchronization with partial timing support from the network
- ITU T G.Suppl.65, Simulations of transport of time over packet networks
- ITU T G.Suppl.68, Synchronization OAM requirements
- ITU-T TR TP-GSTR-GNSS - Considerations on the use of GNSS as a primary time reference in telecommunications (https://www.itu.int/dms_pub/itu-t/opb/tut/T-TUT-HOME-2020-PDF-E.pdf)

Q&A

A decorative horizontal line consisting of a solid green bar on top, followed by a white bar, and then three thin, parallel green lines on the right side.

Tutorial Outline

- Introduction to principles and use cases
- Clock technologies, modeling, and requirements
- IEEE 1588 PTP Telecom Profiles
- Q&A
- IEEE 802.1AS PTP profile for TSN
- IEC/IEEE 60802 TSN Profile for Industrial Automation
- IEEE P802.1DG TSN Profile for Automotive In-Vehicle Ethernet Communications
- Q&A



IEEE 802.1AS PTP profile for TSN

Geoffrey Garner

gmgarner@alum.mit.edu

Contents

- IEEE Std 802.1AS Includes a PTP Profile
- IEEE Std 802.1AS-2011 Features
- New Features in IEEE Std 802.1AS-2020

IEEE Std 802.1AS Includes a PTP Profile

- IEEE Std 802.1AS includes
 - A profile of IEEE Std 1588 (i.e., a PTP profile)
 - Performance requirements and related informative description (mainly oriented towards audio/video applications)
 - Newer TSN applications (e.g., industrial, automotive) will specify their own performance requirements
 - Additional protocol features (not part of IEEE 1588)
- See the section on IEEE 1588 PTP Telecom Profiles for description of the PTP profile concept

IEEE Std 802.1AS Includes a PTP Profile - details

- IEEE Std 802.1AS includes
 - A profile of IEEE Std 1588 (i.e., a PTP profile)
 - Performance requirements and related informative description (mainly oriented towards audio/video applications)
 - These performance requirements and information were developed for 802.1AS-2011, prior to the development of newer TSN applications (e.g., industrial, automotive)
 - Newer TSN applications will specify their own performance requirements
 - Additional protocol features (not part of IEEE 1588)
- See the section on IEEE 1588 PTP Telecom Profiles for description of the PTP profile concept
- IEEE 802.1AS-2011 includes a profile of IEEE 1588-2008
- IEEE 802.1AS-2020 includes a profile of IEEE 1588-2019

IEEE Std 802.1AS-2011 Features

Transport of Time Synchronization (Full-Duplex Ethernet Transport)

- Mean link delay measurement using 1588 peer-to-peer delay mechanism
- Measurement of frequency offset between the two endpoints of a link, (neighborRateRatio) also using peer-to-peer delay messages
- Accumulation of neighbor frequency offsets to obtain frequency offset relative to Grandmaster (source of time)
- Computation of offset of a clock relative to Grandmaster using above measurements and timestamped Sync messages

Mean Link Delay and neighborRateRatio Measurement

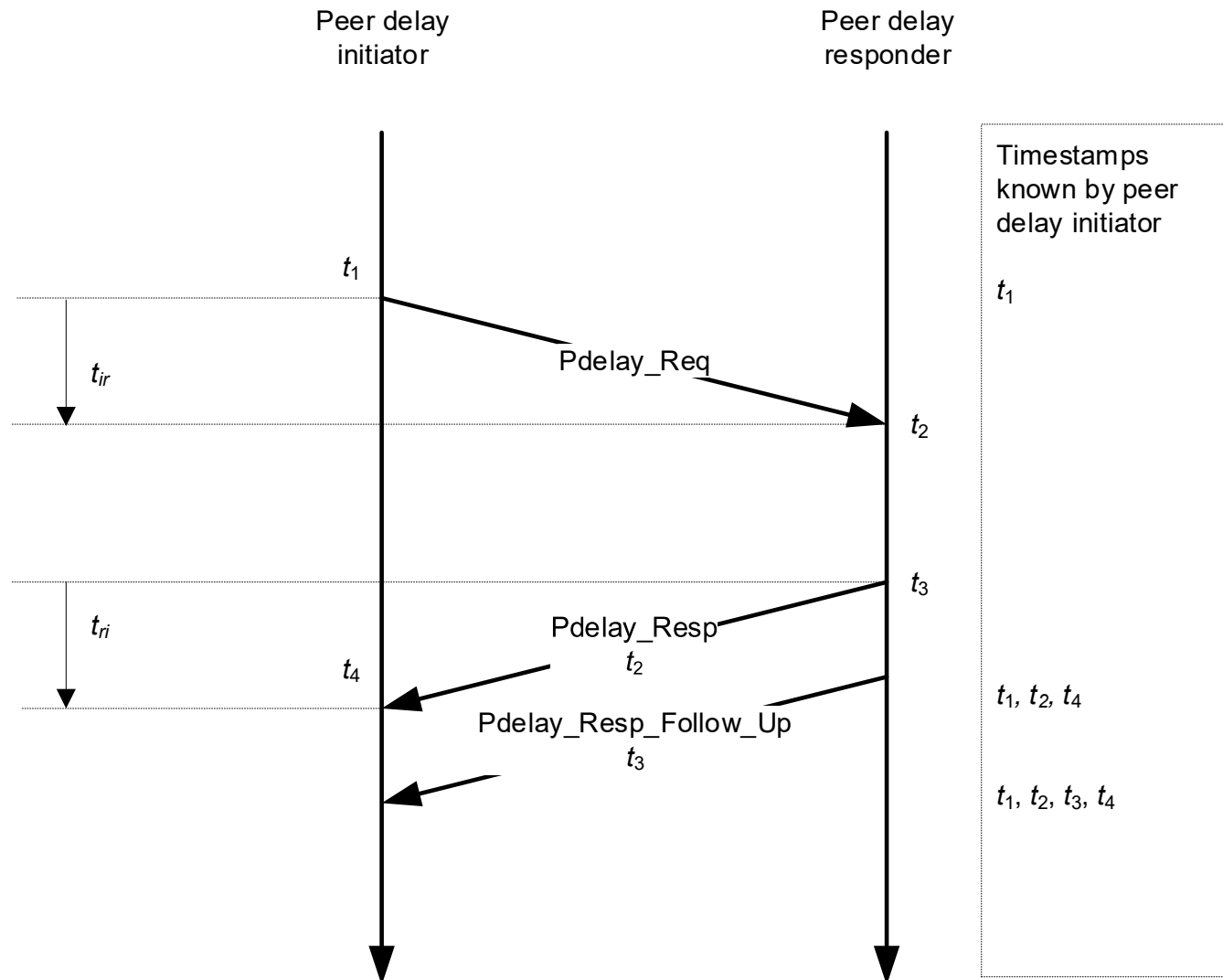

- Mean Link Delay D (at peer delay initiator)

$$D = \frac{(t_4 - t_1) - (t_3 - t_2)}{2}$$

- Additional correction for neighbor frequency offset
- Neighbor frequency offset is measured using successive **Pdelay_Resp_Follow_Up** messages
- Delay asymmetry must be measured externally (outside of PTP); its effect can be included via managed objects

Mean Link Delay and neighborRateRatio Measurement - details

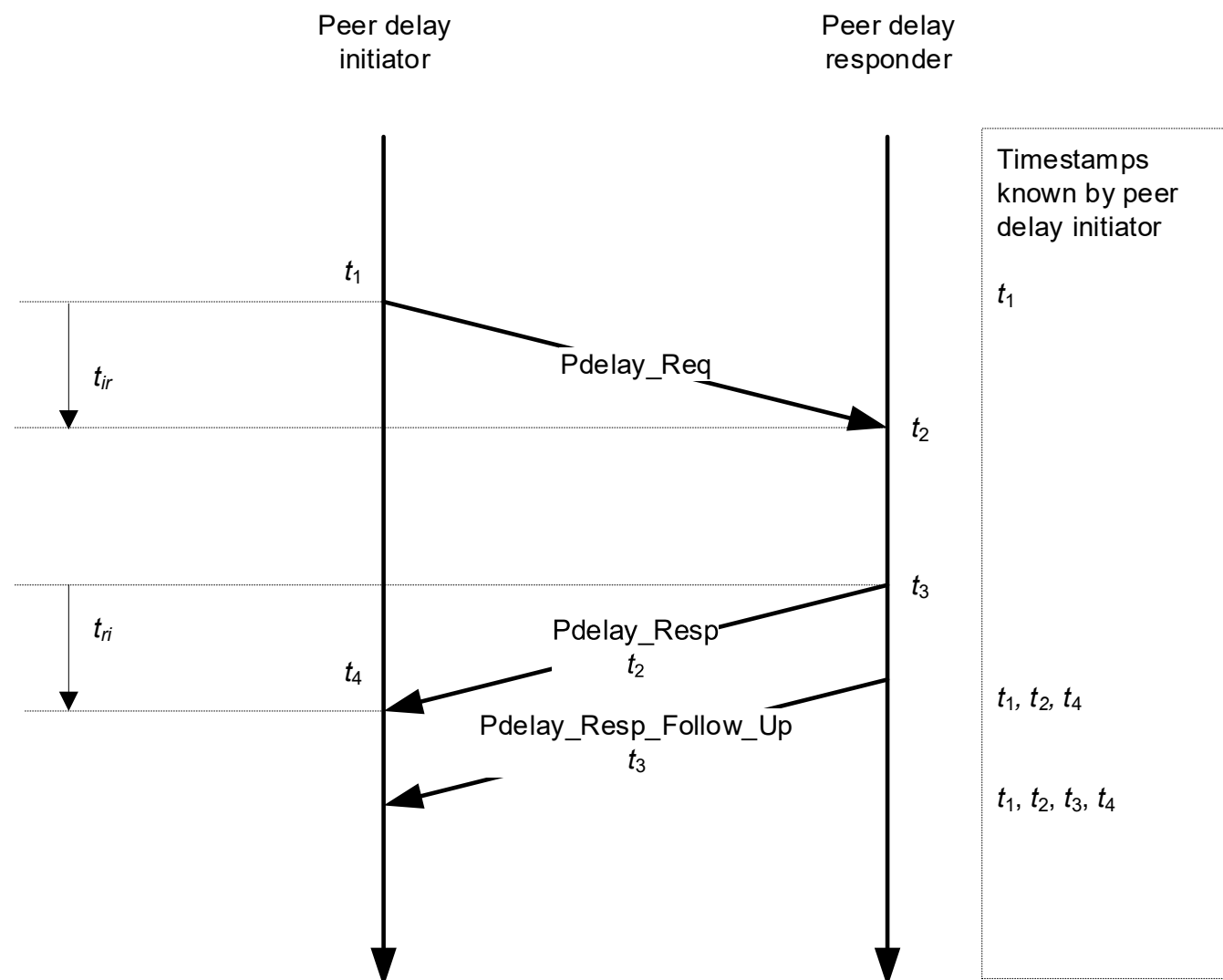

- Mean Link Delay D (at peer delay initiator)

$$D = \frac{r \cdot (t_4 - t_1) - (t_3 - t_2)}{2}$$

- neighborRateRatio (r) is the ratio of the frequency of the peer delay initiator to the frequency of the peer delay responder
- neighborRateRatio is measured using successive Pdelay_Resp_Follow_Up messages to obtain the ratio of elapsed time at the responder to elapsed time at the initiator, of the same time interval
- Delay asymmetry must be measured externally (outside of PTP); its effect can be included via managed objects
- D as computed above is relative to time base of responder

Transport of Time Synchronization

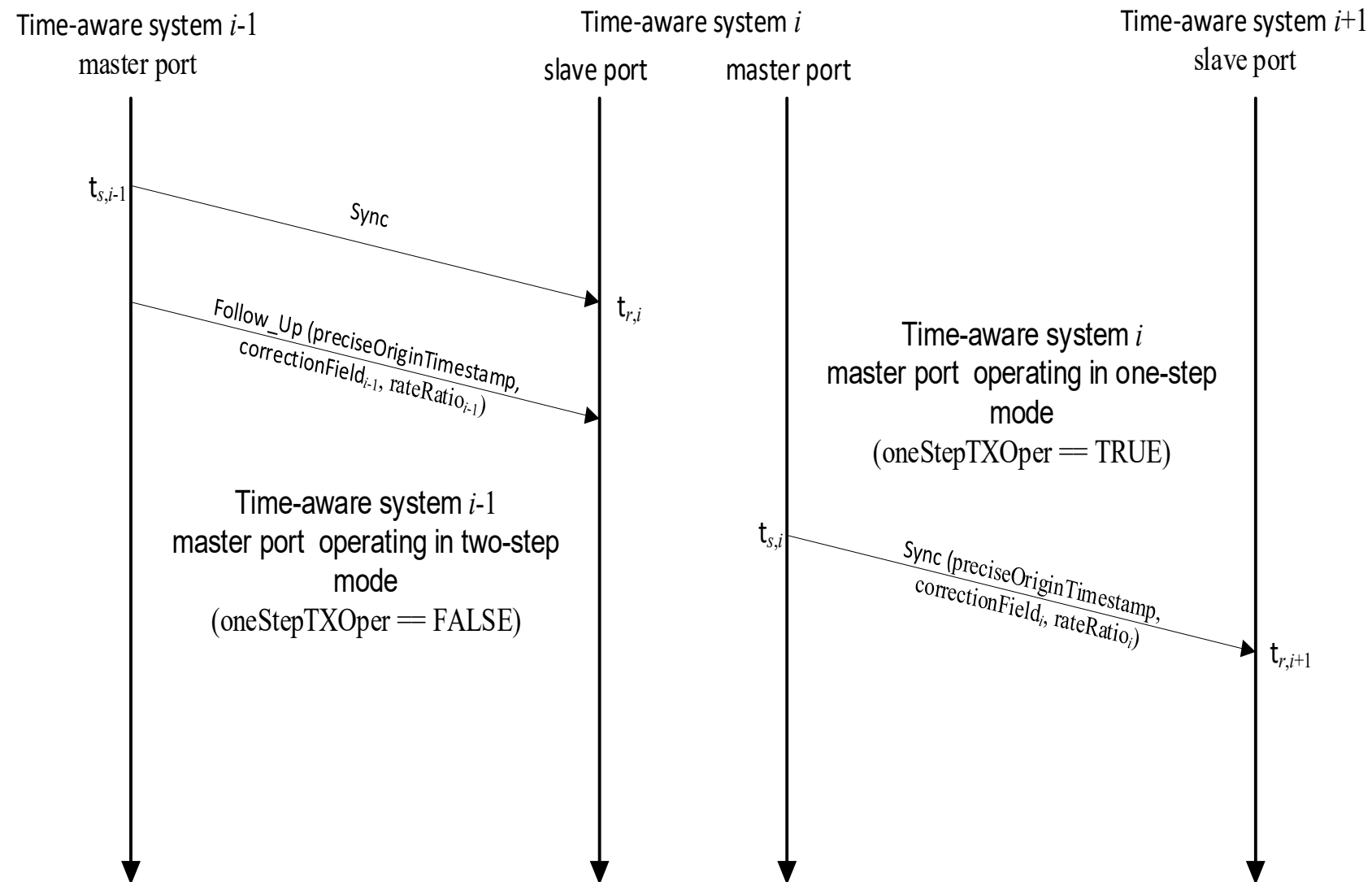

- Master port sends Sync message
 - If one-step, Sync contains timestamp of when message was sent
 - If two-step, timestamp is sent in separate Follow_Up message
- Slave port receives and timestamps Sync message
- Offset from master = (receive timestamp) – (send timestamp) – (mean link delay) – (asymmetry correction if known)
- Offset from master is used to compute master time at instant Sync message is received
- Master time is filtered before being provided to end application (but not in computing master time sent to subsequent downstream system)

Transport of Time Synchronization - details

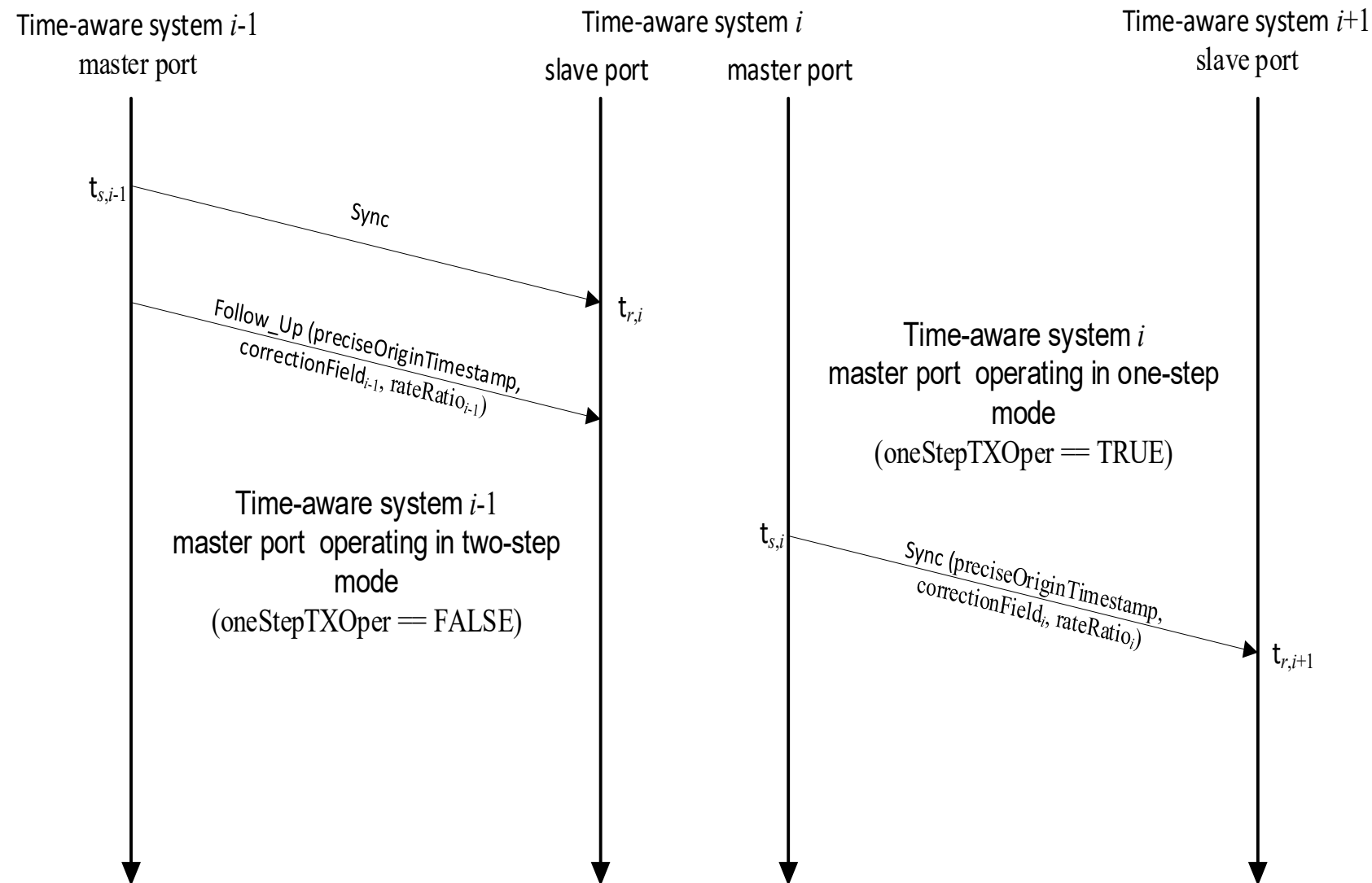

- Master port of system $i-1$ sends Sync message
 - If one-step, Sync contains timestamp of when message was sent
 - If two-step, timestamp is sent in separate Follow_Up message
- Slave port of system i receives and timestamps Sync message
- Offset from master of system i relative to system $i-1$ = (receive timestamp) – (send timestamp) – (mean link delay) – (asymmetry correction if known)
- Offset from master is used to compute master time at instant Sync message is received
- When system i sends Sync message to system $i+1$, master time is computed as (master time when most recent Sync message was received) + (accumulated rate ratio relative to master)([send time] – [receipt time of most recent Sync])
 - This master time is placed in Sync message sent to $i+1$
- Master time is filtered before being provided to end application (but not in computing master time sent to $i+1$)

Layering

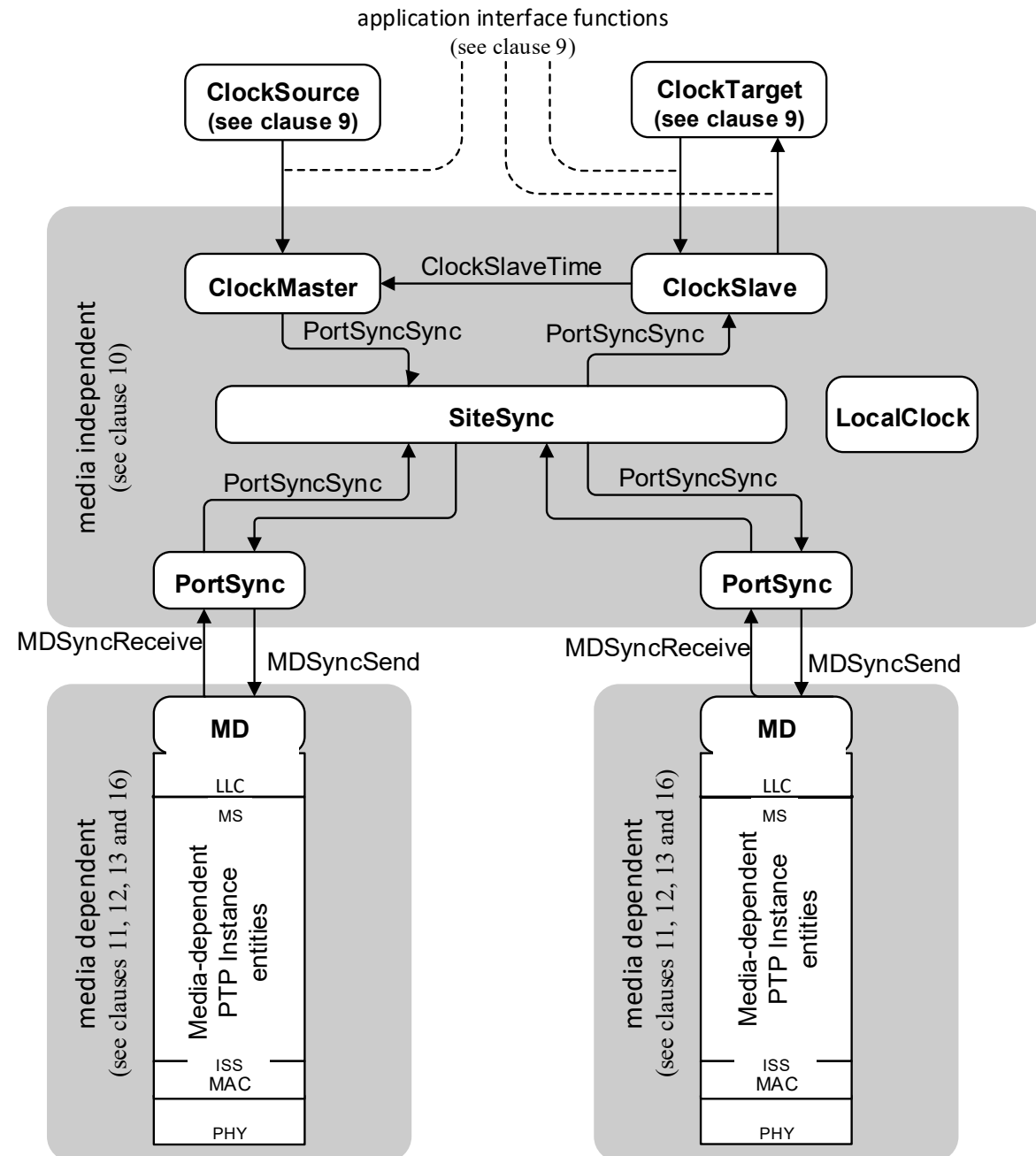

- 802.1AS architecture is divided into media-independent and media-dependent layers
- This division was made because certain media, e.g., IEEE 802.11, IEEE 802.3 EPON, Coordinated Shared Network (e.g., MoCA), have inherent time transport mechanisms (i.e., other than IEEE 1588)
- The description on the previous slides uses the timing messages of IEEE 1588, and is used for full-duplex Ethernet transport (which does not have an inherent timing mechanism)

Layering - details

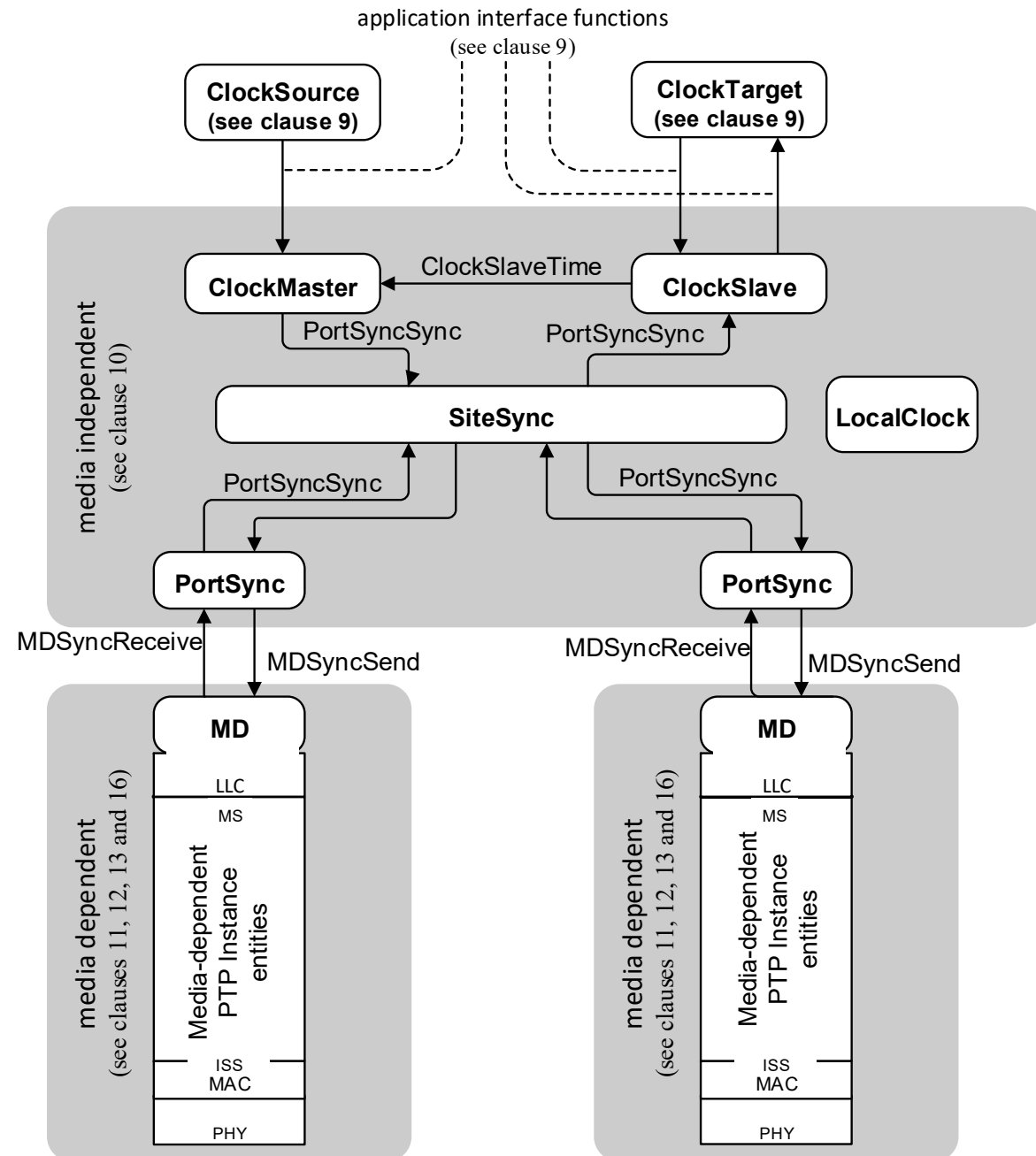

- 802.1AS architecture is divided into media-independent and media-dependent layers
- This division was made because certain media, e.g., IEEE 802.11, IEEE 802.3 EPON, Coordinated Shared Network (e.g., MoCA), have inherent time transport mechanisms (i.e., other than IEEE 1588)
 - These mechanisms allow the endpoints of a link to be synchronized, but do not provide for end-to-end network synchronization
 - The mechanisms were developed for media-specific reasons, e.g., location determination in 802.11
- The description on the previous slides uses the timing messages of IEEE 1588, and is used for full-duplex Ethernet transport (which does not have an inherent timing mechanism)
- Primitives are used to transfer media-independent information from between the media-independent and media-dependent layers
 - The needed information is provided by the media-dependent layer in a common format
- The architecture also defines common (abstract) application interfaces

Synchronization Spanning Tree

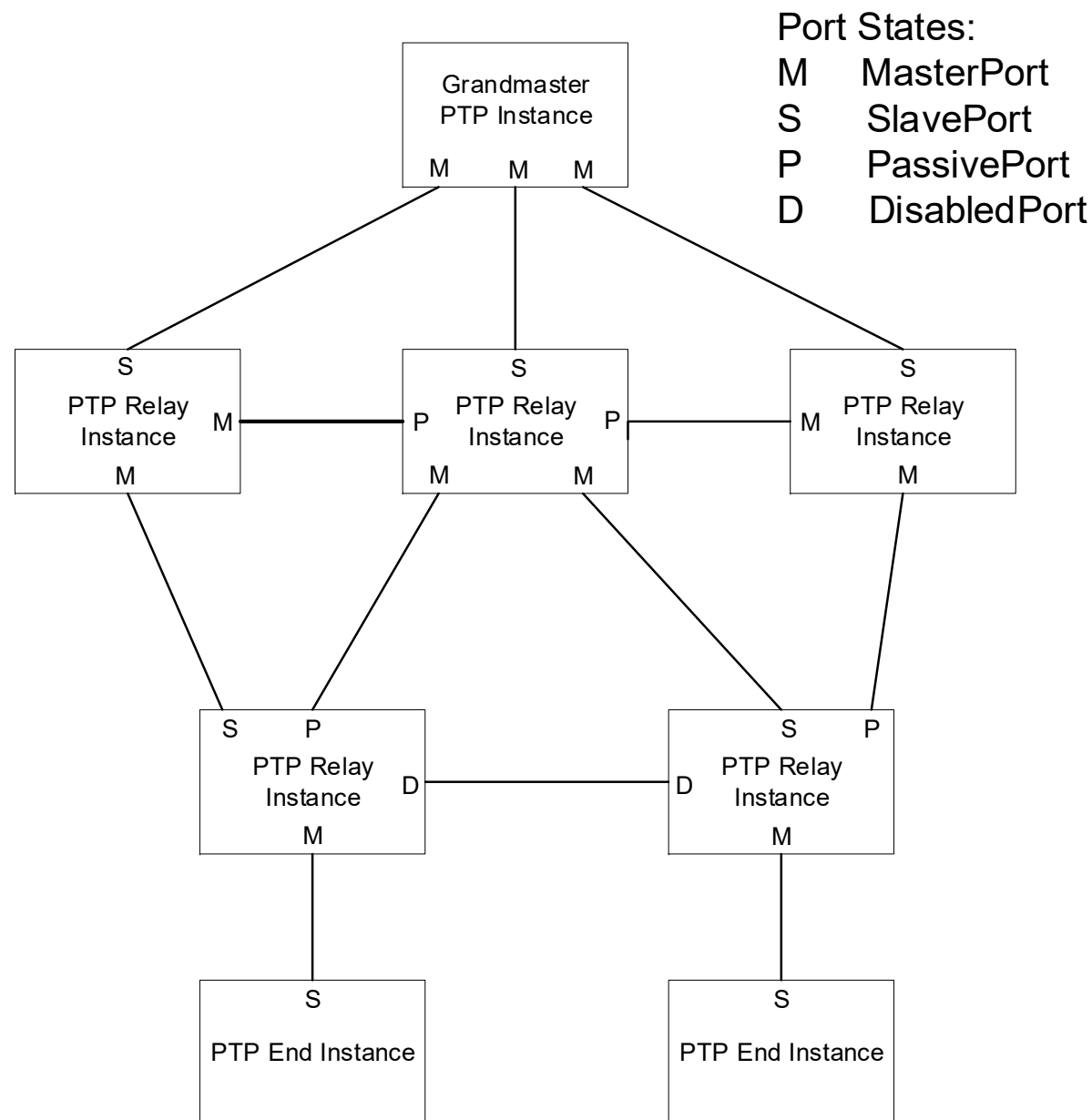

- 802.1AS uses the 1588 Best Master Clock Algorithm (BMCA) to form the synchronization hierarchy, i.e., spanning tree
- The BMCA is functionally equivalent to the portion of 802.1Q Rapid Spanning Tree Protocol (RSTP) that sets the 802.1Q port roles (called *port states* in 1588 and 802.1AS)
 - Note: It is planned to replace the terms *master* and *slave* with alternate terms, which will be recommended by 1588, that are more inclusive

802.1/1588 Port States	
802.1AS/1588	Corresponding 802.1Q terminology
MasterPort	Designated Port
SlavePort	Root Port
PassivePort	Alternate Port

Best Master Clock Algorithm

- Each MasterPort sends Announce messages to its neighboring port
- An Announce message contains attributes of the clock that the port thinks is the best master clock
- On receipt of an Announce message, the BMCA is invoked, and port states are set
- The algorithm operates at each PTP Instance, and the network converges to a spanning tree with the best clock as the grandmaster (root)

Clock Attributes	
Priority1	Used to override all other attributes
ClockClass	Denotes the traceability of the clock
clockAccuracy	Denotes the time accuracy of the clock
offsetScaledLogVariance	Characterizes the frequency stability of the clock
Priority2	Used to set preferences among clocks for which the above attributes are the same
timeSource	Denotes the source of time (for information; not used for best master selection)

IEEE Std 802.1AS-2020 Features

New Features of IEEE Std 802.1AS-2020

- External port configuration
- Fine Timing Measurement (FTM) for 802.11 transport
- Management support for delay asymmetry measurement (using line-swapping)
- Multiple domains
- Common mean link delay service to make mean link delay measurements that are common across all domains
- One-step ports (1588-2008 allowed one-step clocks, but 802.1AS-2011 was limited to two-step)
- Automatic signaling of 802.1AS capability and determination of whether the port at the other end of the link is capable of executing the 802.1AS protocol

New Features of IEEE Std 802.1AS-2020 - details

- External port configuration
 - Alternative to BMCA; can be used with external mechanism when redundancy is desired via multiple domains
- Fine Timing Measurement (FTM) for 802.11 transport
 - Provides improved time accuracy compared to Timing Measurement (TM) used in 802.1AS-2011
- Management support for delay asymmetry measurement (using line-swapping)
- Multiple domains
 - 1588-2008 allowed multiple domains, but 802.1AS-2011 was limited to a single domain (domain 0)
 - In a node that supports multiple domains, each domain is a separate instance of PTP (i.e., a separate *PTP Instance*)
- Common mean link delay service to make mean link delay measurements that are common across all domains
 - This is useful because mean link delay for 802.3 transport depends on the physical characteristics of the link and should not vary from one domain (PTP Instance) to another
- One-step ports (1588-2008 allowed one-step clocks, but 802.1AS-2011 was limited to two-step)
- Automatic signaling of 802.1AS capability and determination of whether the port at the other end of the link is capable of executing the 802.1AS protocol

Multiple Domains

- Every time-aware system supports domain 0 (for backward compatibility)
- Some time-aware systems have only domain 1 active
- Domains 0 and 1 use different timescales

Note: all the “bridges” and “routers” in this figure are examples of time-aware systems that contain at least one PTP Relay Instance, and the end stations are time-aware systems that contain at least one PTP End Instance.

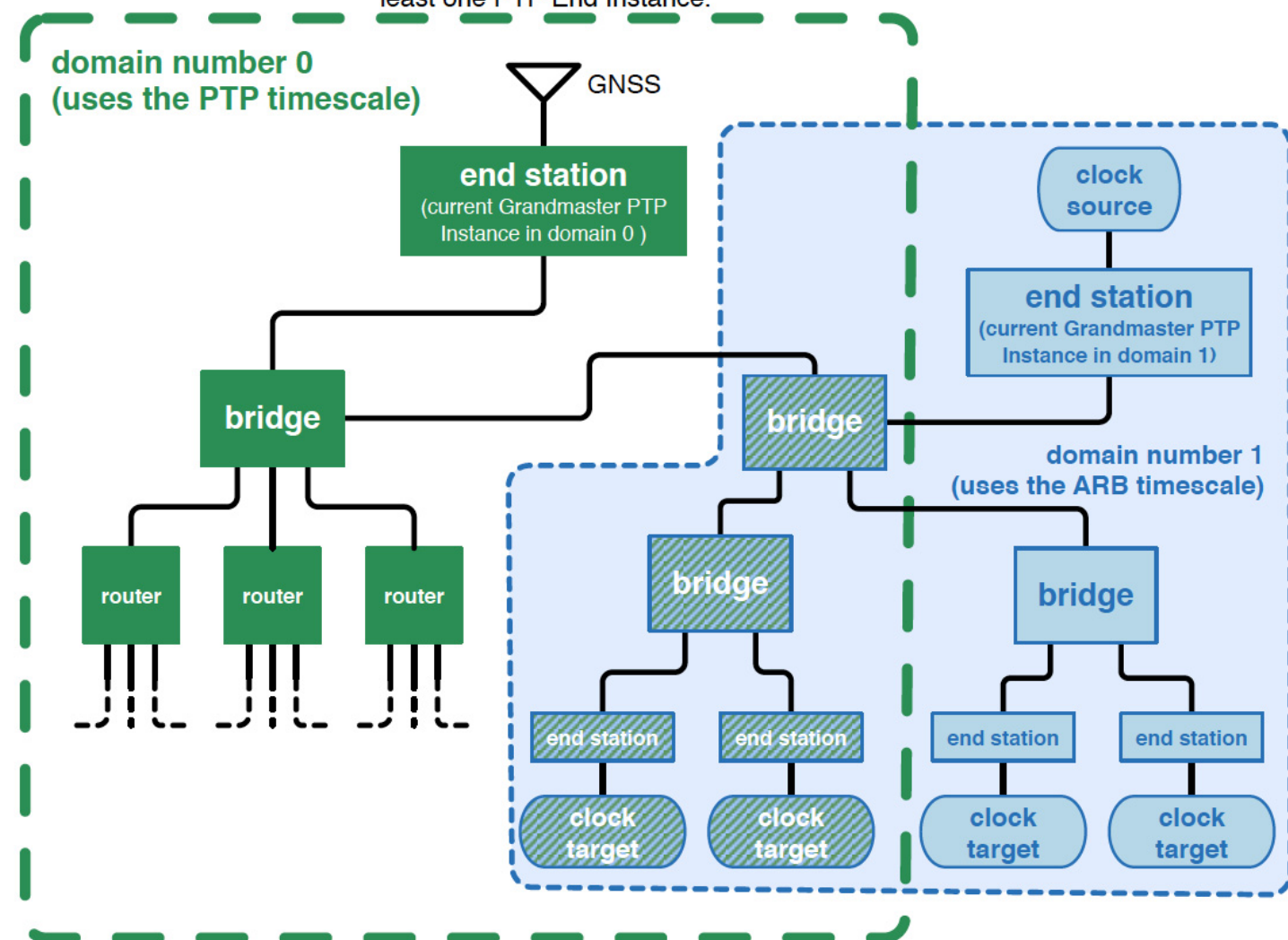
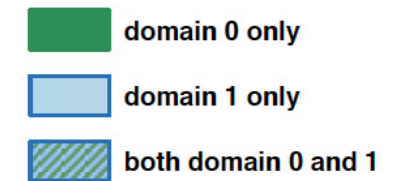

Backward Compatibility

- 802.1AS-2020 is backward compatible with 802.1AS-2011
 - This means that an 802.1AS-2011 time-aware system (PTP Instance) will interoperate with an 802.1AS-2020 PTP Instance provided new features of 802.1AS-2020 are not used
 - The 802.1AS-2020 state machines that automatically signal 802.1AS capability can determine if the port at the other end of a link is an 802.1AS-2011 port, and reflect this when they receive, process, and transmit messages

Backward Compatibility - details

- 802.1AS-2020 is backward compatible with 802.1AS-2011
 - This means that an 802.1AS-2011 time-aware system (PTP Instance) will interoperate with an 802.1AS-2020 PTP Instance provided
 - BMCA, and not external port configuration, is used to construct the synchronization spanning tree
 - domainNumber is 0
 - TM is supported if the transport is 802.11
 - 802.1AS-2020 requires PTP Relay Instances (bridges) to support at least TM, but PTP End Instances are required to support at least one of TM or FTM
 - asymmetryMeasurementMode cannot be used with 802.1AS-2011 systems
 - The 802.1AS-2020 state machines that automatically signal 802.1AS capability can determine if the port at the other end of a link is an 802.1AS-2011 port, and reflect this when they receive, process, and transmit messages

IEC/IEEE 60802 TSN Profile for Industrial Automation

Jordon Woods

Jordon.Woods@analog.com

IEC/IEEE 60802 TSN Profile for Industrial Automation

- Time-Sensitive Networking technology provides the features required for industrial networks:
 - Meeting low latency and latency variation requirements concerning data transmission.
 - Efficient exchange of data records on a frequent time period.
 - Reliable communications with calculable downtime.
 - High availability meeting application requirements
- The 60802 Profile selects “features, options, configurations, defaults, protocols, and procedures of bridges, end stations, and LANs to build industrial automation networks.”

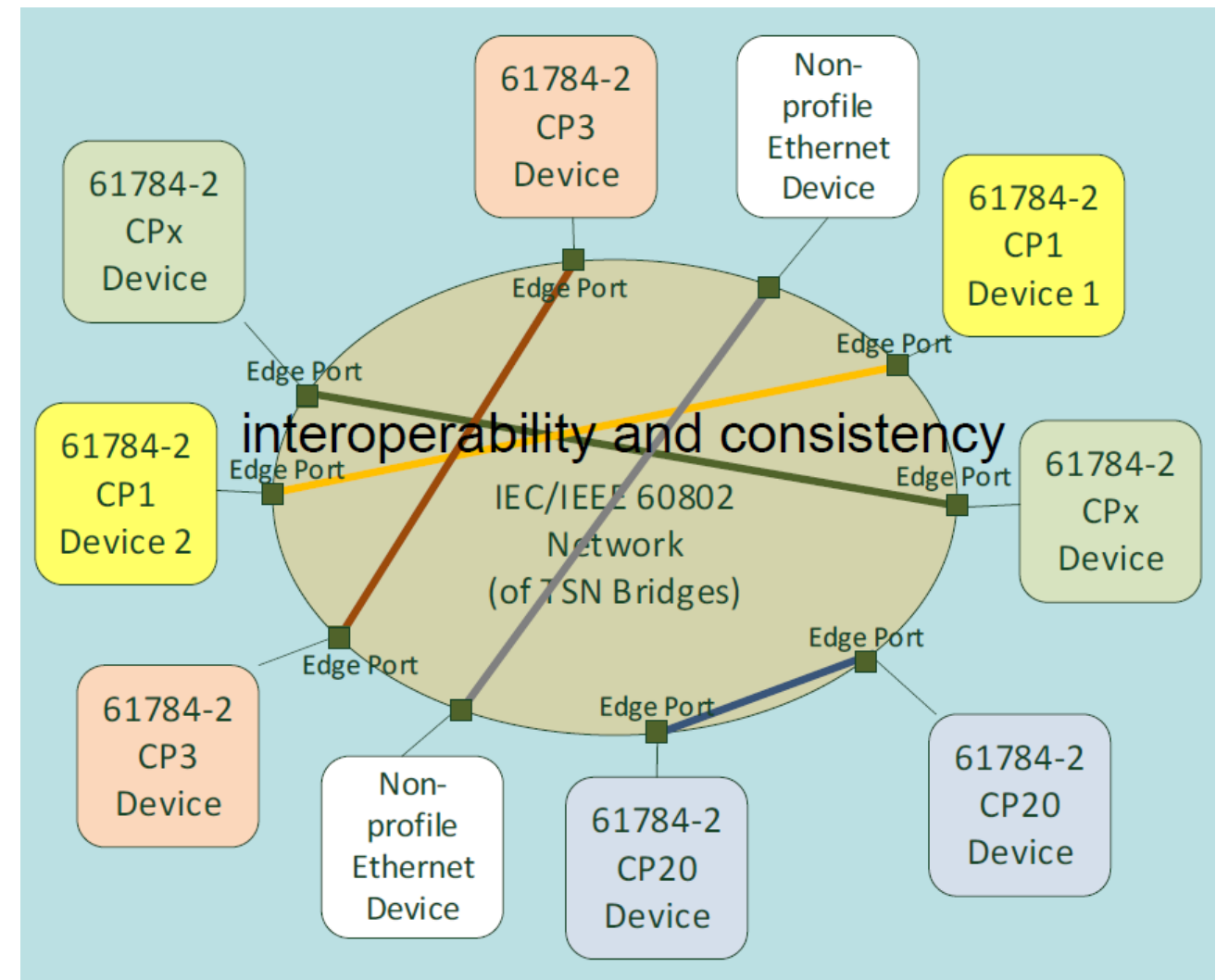

Industrial Automation Synchronization Requirements



- Environmental
 - -40 to +85°C
 - Life cycle of 10+ years running 24/7
 - Frequency deviation due to
 - Production process tolerances and aging
 - Temperature and temperature change
 - Supply voltage and supply voltage quality
 - Shock and vibration
- Topologies
 - Physical constraints make cabling for star topologies impractical
 - The construction of the application naturally lends itself to point-to-point connectivity

Control Applications and Line Topologies

- Utilization of line topologies is prevalent in motion applications utilizing embedded switch technology
- There can be many hops along the line (64 hops or greater)
- Control loop times can be in the 10 s of microseconds
- $\max|TER|$ of the synchronized time, relative to the Grandmaster Clock, is expected to be $1 \mu\text{s}$ across 64 network hops (goal: 100 hops)

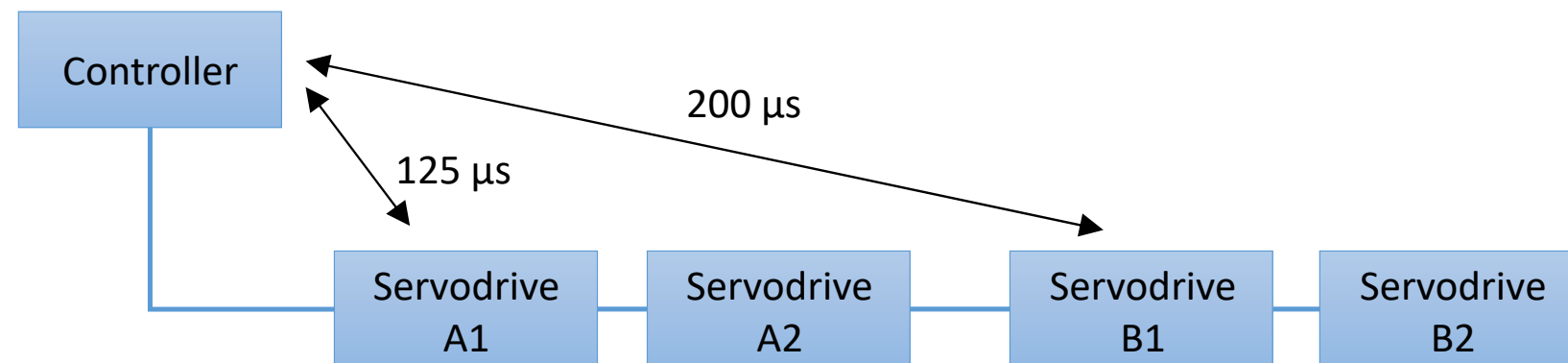

Requirements for Scheduled Traffic

- **Scheduled Traffic (802.1Qbv)** introduces transmission gates for time-based control of queues:
 - A tick granularity of less than or equal to 10 ns
 - A gating cycle of 250 μ s to 10 ms at the 100 Mbps data rate
 - A gating cycle of 31.25 μ s to 1 ms for the 1 Gbps data rate and above.
 - Timing points of less than or equal to 10 ns

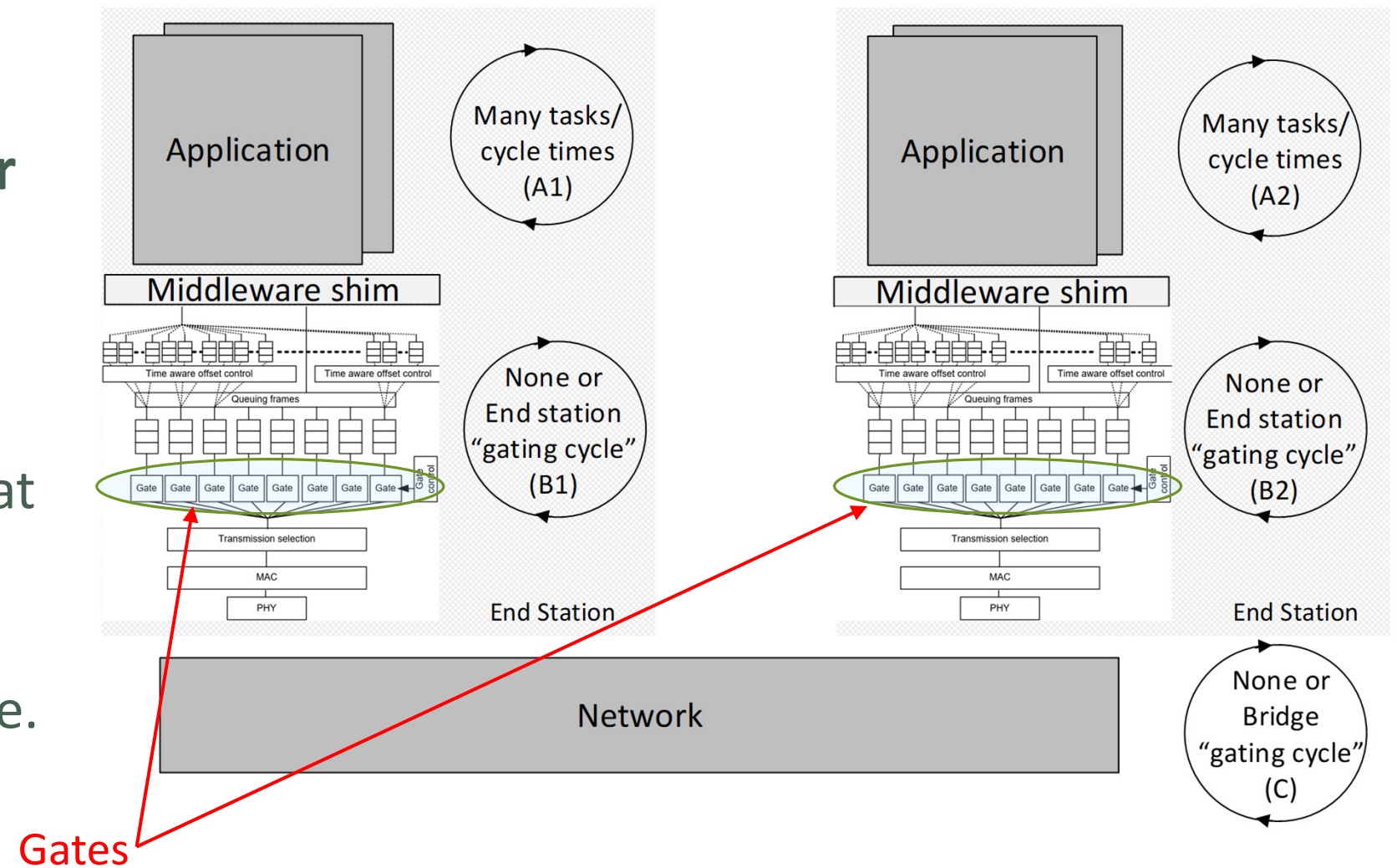

Industrial Automation Synchronization Requirements

- Industrial automation applications require:
 - synchronized time that is traceable to a known source (i.e. Global Time)
 - a source of time for use by the application (i.e. Working Clock).
 - A secondary domain for both Global Time and working clock may be optionally supported

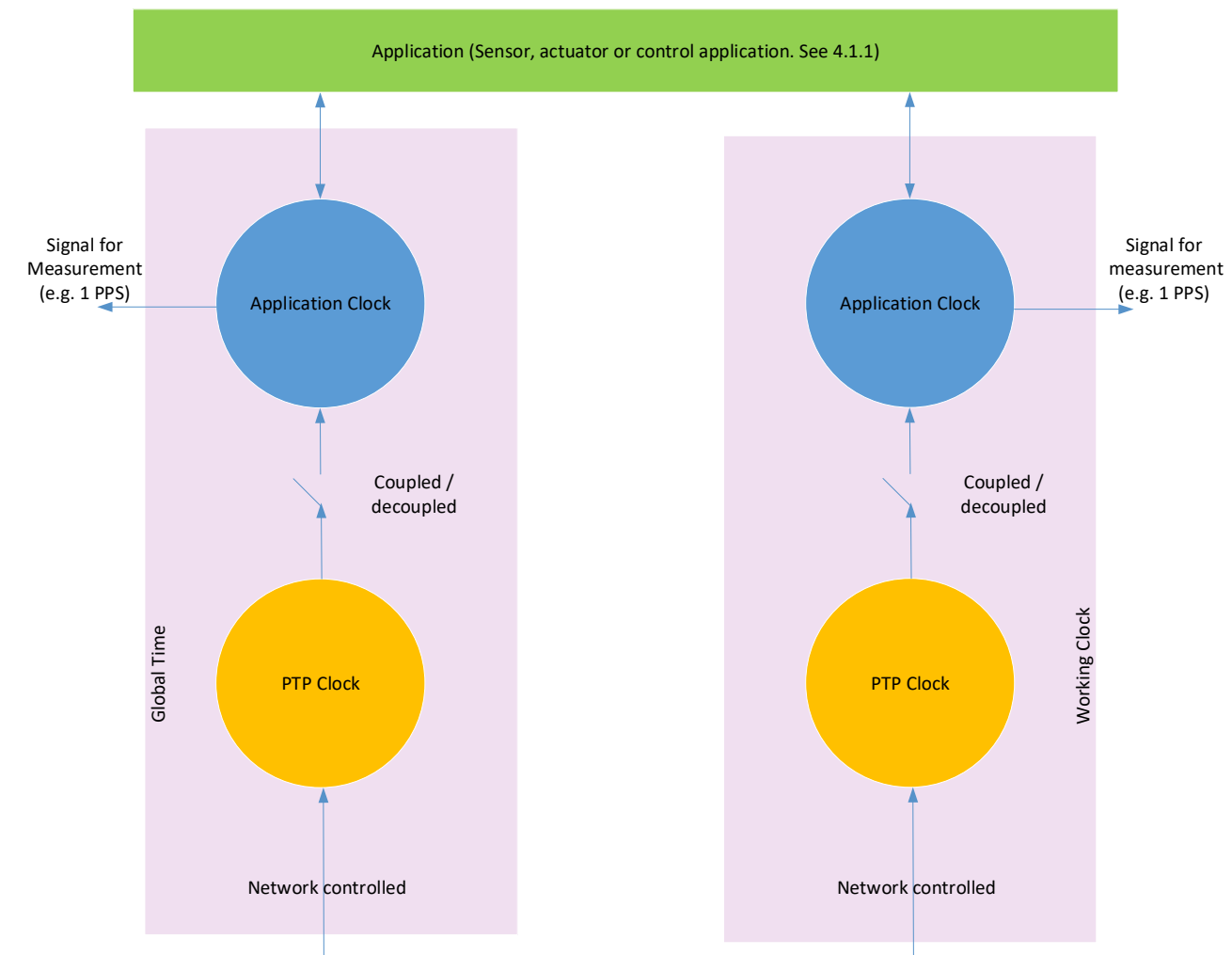

Domain	primary.domainNumber	secondary.domainNumber
Working Clock	20	21
Global Time	0	1

A Work in Progress

- Currently, the IEC/IEEE 60802 Joint Project is engaged in simulations to establish that the 1 μ s goal is achievable using IEEE 802.1AS-2020
- This work will establish default parameters for industrial applications including:
 - Timestamp accuracy
 - Timestamp precision
 - Residence time
 - Message intervals (sync, pdelay, etc.)

IEEE P802.1DG TSN Profile for Automotive In-Vehicle Ethernet Communications

Max Turner

max.turner@ethernovia.com

IEEE P802.1DG - TSN Profile for Automotive In-Vehicle Ethernet Communications

- Automotive Networks introduction
 - Topologies
 - Latency Requirements and Traffic Types
- Life Cycle of an automotive network
 - Manufacturing
 - “daily” Start-Up
 - Maintenance
- Recommendations for Automotive TSN Implementations
 - Protocols
 - Safety
 - Redundancy
 - Security
- Implementation Profiles

Related Work (examples)

- AVnu Automotive Profile for AVB (<https://avnu.org/automotive/>)
 - AVB Interoperability
 - 802.1AS Recovered Clock Quality Testing
- OPEN Alliance (<https://www.opensig.org/>)
 - Switch Requirements
 - PHY testing
 - Wake-Up and Sleep
- IEEE 1588: proposed PAR on Time-Sync Monitoring
 - Discussion just starting

Choosing Oscillators

- Automotive is still very Hardware Cost driven
- Temperature
 - Starting a vehicle in Sweden in winter
 - vs. starting a vehicle in South-Africa in summer
- Power-Consumption while Parking
 - Privately owned Vehicles are parked for 95% of the time
 - Convertibles may be parked (under ground) for several months
 - Especially ICE-Vehicles must minimize power consumption while parked
 - EV's have different challenges while parked (conversion & charging efficiency)

Holding a Microsecond after Loss of Sync
(circa 2020)

	Temperature Compensated Crystal Oscillator (TCXO)	Oven Controlled Crystal Oscillator (OCXO)	Chip Scale Atomic Clock (CSAC)	Rb Oscillator (5E-12/mo. aging)	Cs Beam-Tube Oscillator
Range of times to hold a microsecond	10 minutes – 1 hour	1 – 12 hours	3-15 hours	8 hours – 3 days	10-300 days
Cost Range	\$5-20	\$50-500	\$1.5K-3K	\$500-1500	\$20K - \$50K

Start-Up and Availability

- Vehicles need to Start Up from Low Power within a Few Seconds
 - FMVSS No. 111 – Rear-View Cameras
 - Clearing windshield for ADAS Cameras (e.g., LDP)
- GNSS may not be available while the Vehicle is parked
- (Cellular) Data Connection (GSM, 5G, WiFi) may not be available while the Vehicle is parked
- Some Vehicles cross Time-Zones frequently
 - (e.g., near the Michigan/Wisconsin state border)
- Conclusion: Use the “Right Clock” for each Application

Applications of “Time” in the Vehicle

- AVB: Lip-Sync replay of Audio and Video from various sources (live and stored) on distributed Screens and Speakers (48 kHz ↔ 21 μs)
- V2x: Exchange events and data with a Backend or other Vehicles
- Application-Delay Measurement: “How long ago was this GPS Position recorded and what does the model say where the vehicle has moved since?”
- Link-Delay Measurement: “Can we detect Man-in-the-Middle attacks via Link-Delays?”

Monitoring Time in Safety-Related Systems.

- For Sensor-Fusion it is important to understand WHEN each of the Sensors detected an “Object”
- PTP at its core is a One Way Distribution System, no Feedback is available form the Subordinate-Clock
- How can we check the Subordinate Clock has actually synchronized?

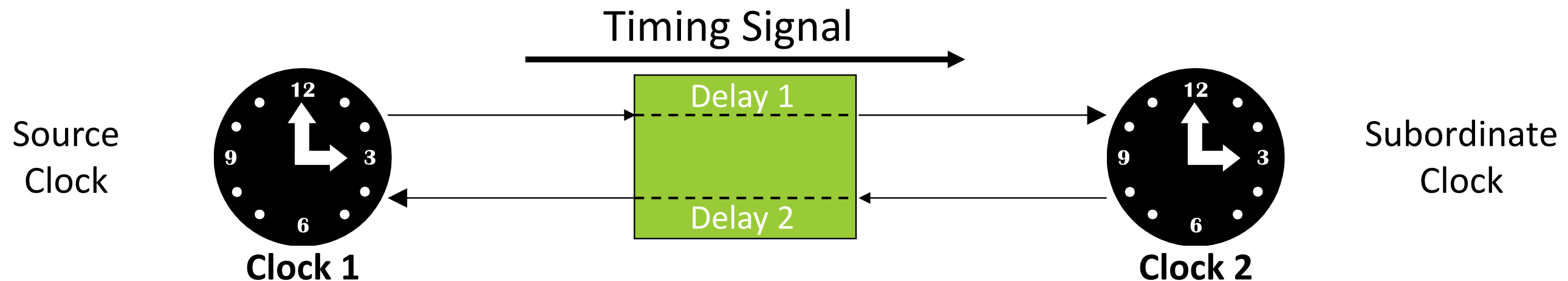

The “Byzantine” Bridge Error

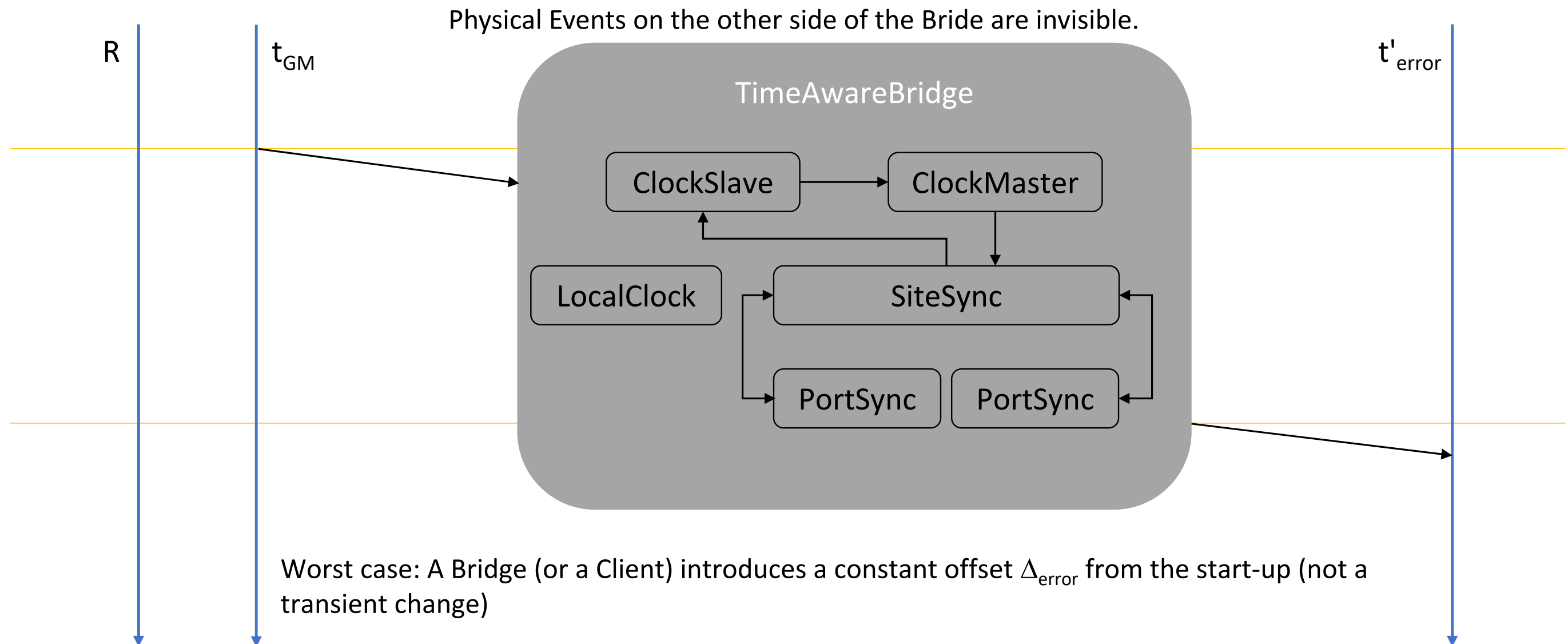

IEEE 802.1DG – Automotive Acronyms

- ADAS – Advanced Driver Assistance Systems
- AVB – Audio Video Bridging
- EV – Electric Vehicle
- FMVSS – US Federal Motor Vehicle Safety Standard
- GNSS – Global Navigation Satellite System
- GPS – Global Positioning System
- GSM – Global System for Mobile communication
- ICE – Internal Combustion Engine
- LDP – Lane Departure Warning
- V2x – wireless Vehicle to everything communication

Q&A

A decorative graphic consisting of a solid green horizontal bar that transitions into a white background. On the right side, there are several thin, parallel white lines of varying lengths, creating a layered, modern look.

Tutorial Outline

- Introduction to principles and use cases
- Clock technologies, modeling, and requirements
- IEEE 1588 PTP Telecom Profiles
- Q&A
- IEEE 802.1AS PTP profile for TSN
- IEC/IEEE 60802 TSN Profile for Industrial Automation
- IEEE P802.1DG TSN Profile for Automotive In-Vehicle Ethernet Communications
- Q&A



References for Standardization Activities

- ITU-T SG15 (Q13):
 - <https://www.itu.int/en/ITU-T/studygroups/2017-2020/15/Pages/default.aspx>
- ATIS SYNC:
 - <https://www.atis.org/committees-forums/sync/>
- IEEE 1588 WG:
 - <https://sagroups.ieee.org/1588/>
- IEEE 802.1 WG, TSN TG, IEC/IEEE 60802, IEEE P802.1DG:
 - <https://ieee802.org/1>
 - <https://1.ieee802.org/tsn/>
 - <https://1.ieee802.org/tsn/iec-ieee-60802/>
 - <https://1.ieee802.org/tsn/802-1dg/>

WORKSHOP
— ON —
SYNCHRONIZATION
— AND —
TIMING SYSTEMS

MARCH 30, 31 AND APRIL 1

30 Years in Sync

Time-Sensitive Everything for 5G and Connected Industries

Thank you!

Further Tutorials Coming Soon
Visit <https://wsts.atis.org/tutorials>

