

Effects of long RTT - A case for RTT adaptivity

Cyriel Minkenberg & Mitch Gusat

IBM Research GmbH, Zurich

November 1, 2007

Baseline Input-Generated Hotspot

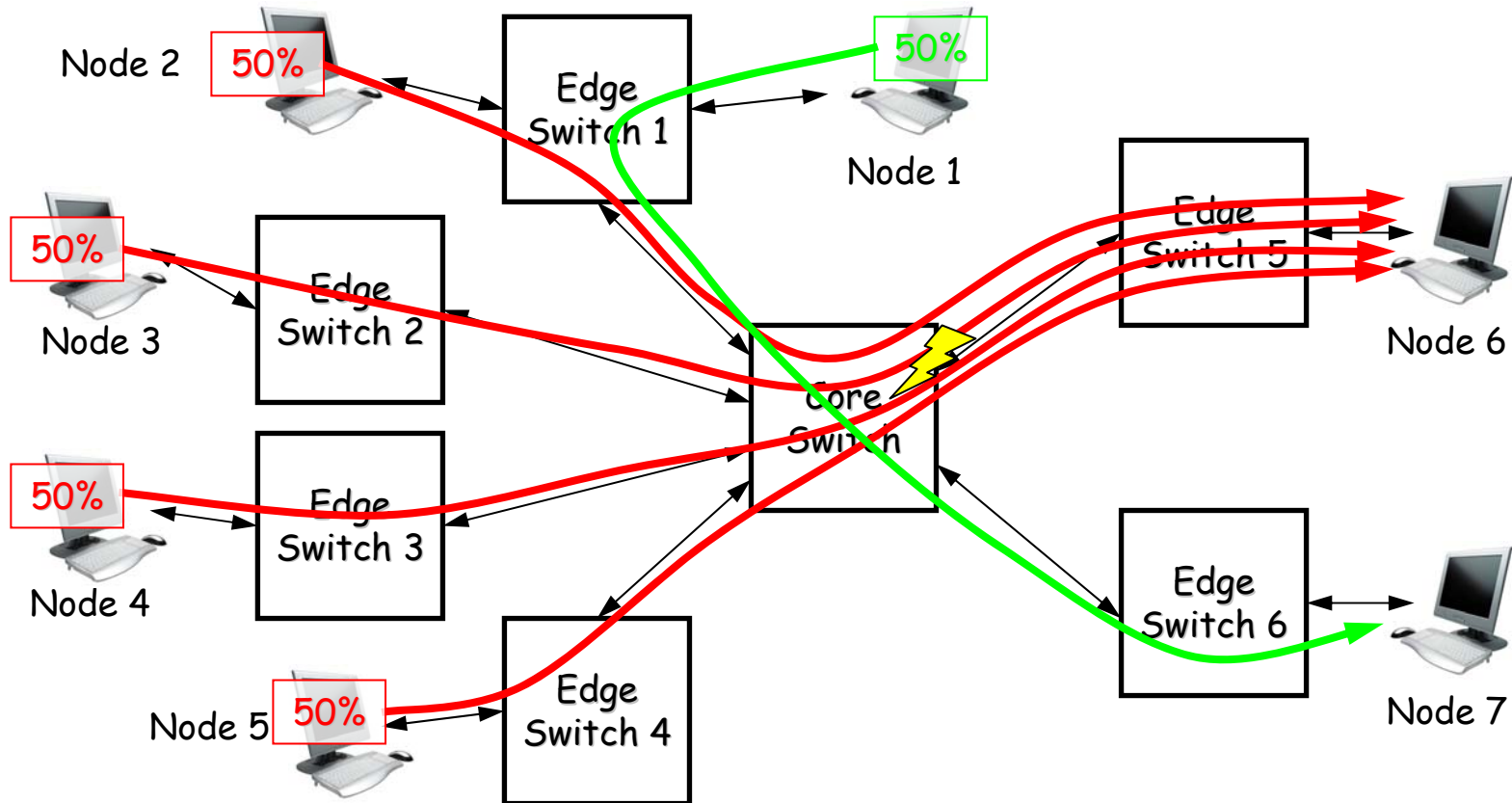

- Four culprit flows of 5 Gb/s each from nodes 2, 3, 4, 5 to node 6 (hotspot)
- One victim flows of 5 Gb/s from node 1 to node 7
- Fair allocation provides 2.5 Gb/s to all culprits and 5 Gb/s to the victim

Simulation Parameters

- Baseline scenario, $t_{\text{hotspot}} = 0.1 - 1.0 \text{ s}$
- $M = 1.5 \text{ MB/port}$
- Unlimited input buffers
- $Q_{\text{eq}} = 375 \text{ KB}$
- $P_s = 1\%$ (QCN: 1-10%)
- QCN active increase
 - $\text{to_thresh} = \text{packet_size} / \text{p_sample}$
 - $R_i = 12 \text{ Mb/s}$
- Drift enabled: 4 Mb/s every 20 ms
- ECM_MAX enabled, $Q_{\text{mc}} = 1.5 \text{ MB}$
- No ECM_(0,0), no PAUSE
- Per-link RTT = [2 us, 20 us, 50 us, 200 us, 500 us, 1ms]
 - Note that RP \Leftrightarrow CP RTT = 2*link RTT
- 8-bit quantization
- $W = [2, 8, 32]$

Hot queue length, QCN, $P_{\text{sample_base}} = 1\%$

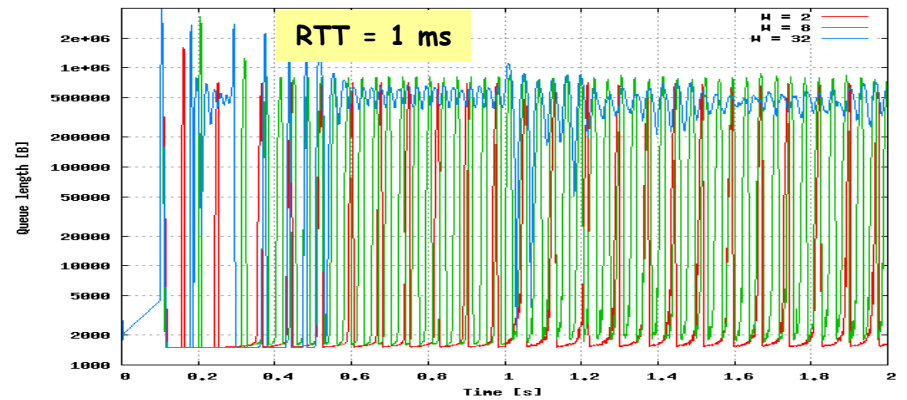
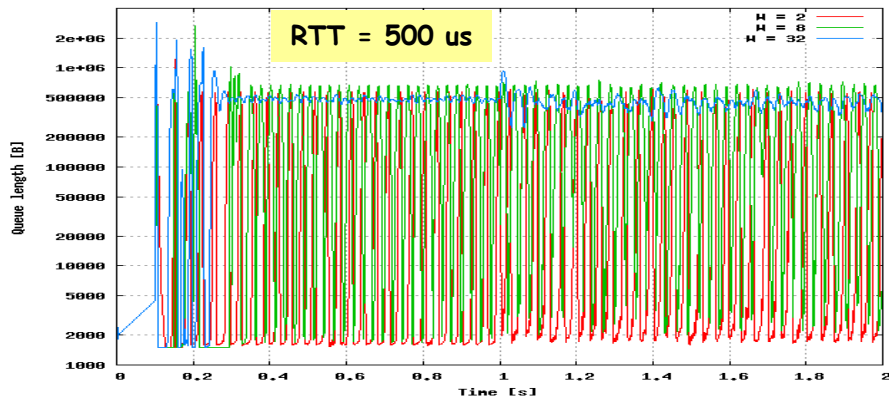
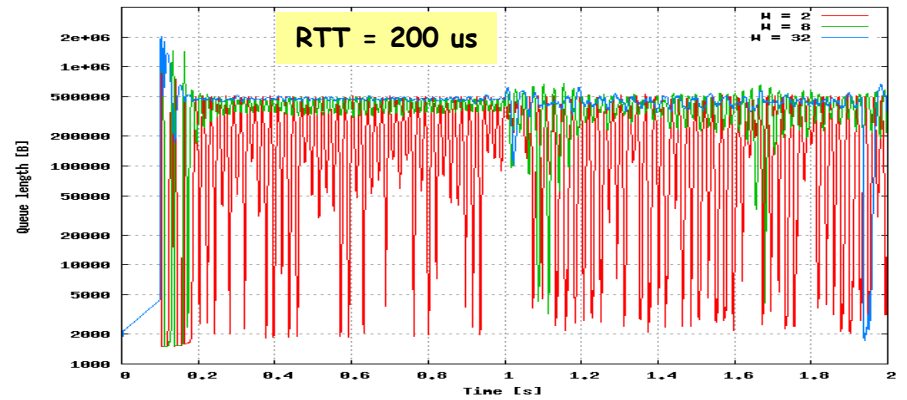
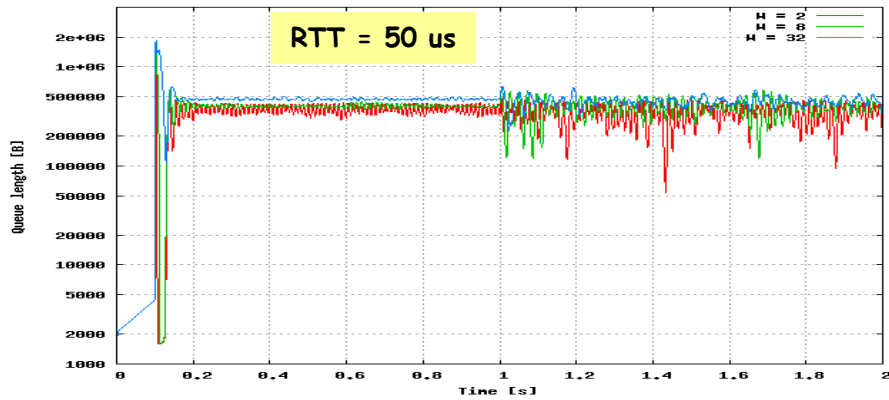
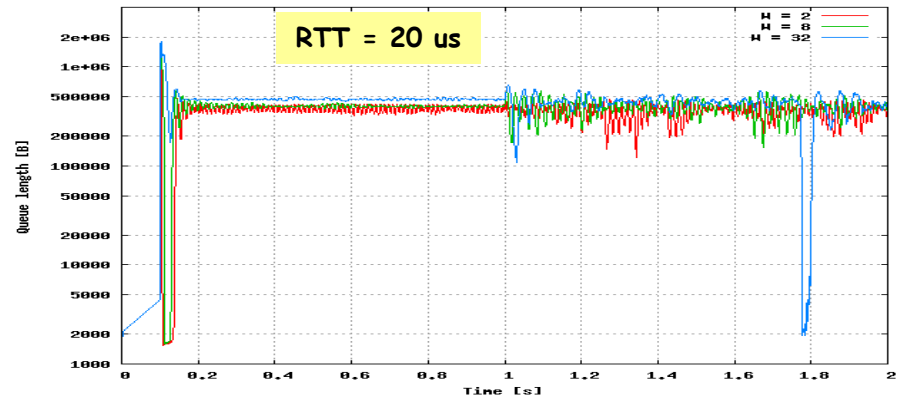
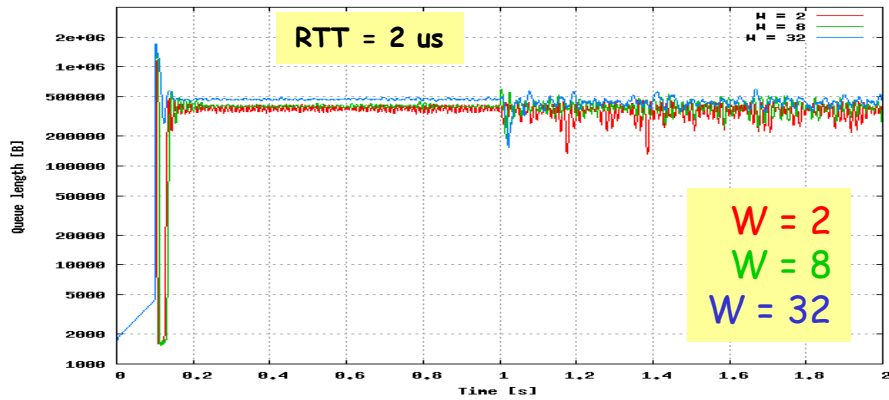

Hot port throughput, QCN, $P_{\text{sample_base}} = 1\%$

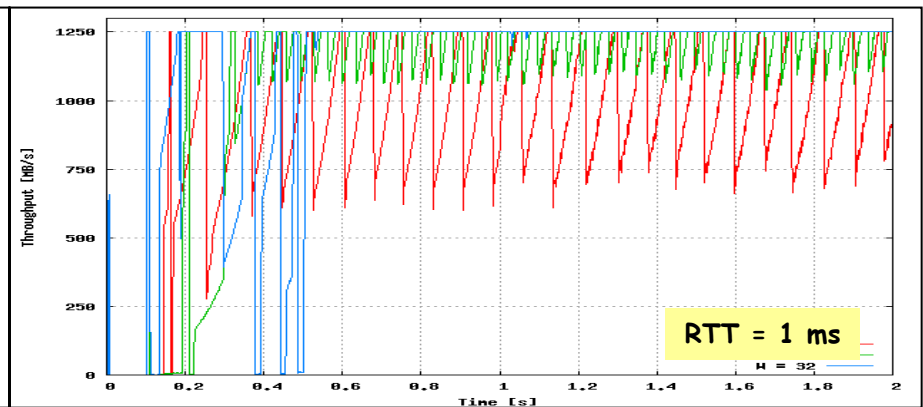
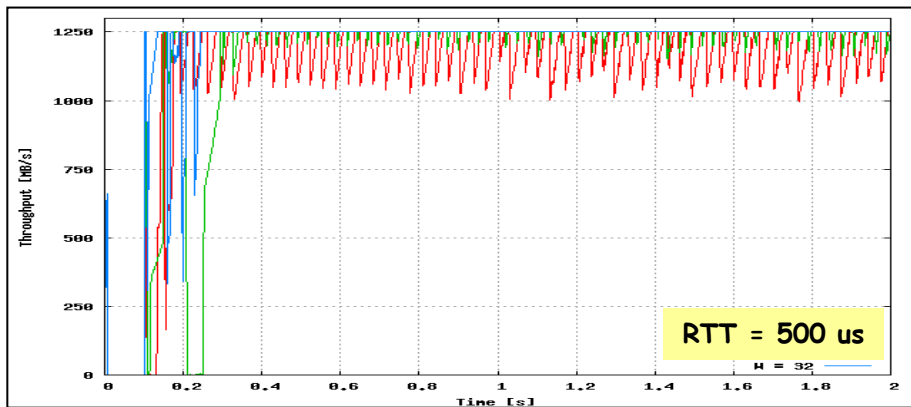
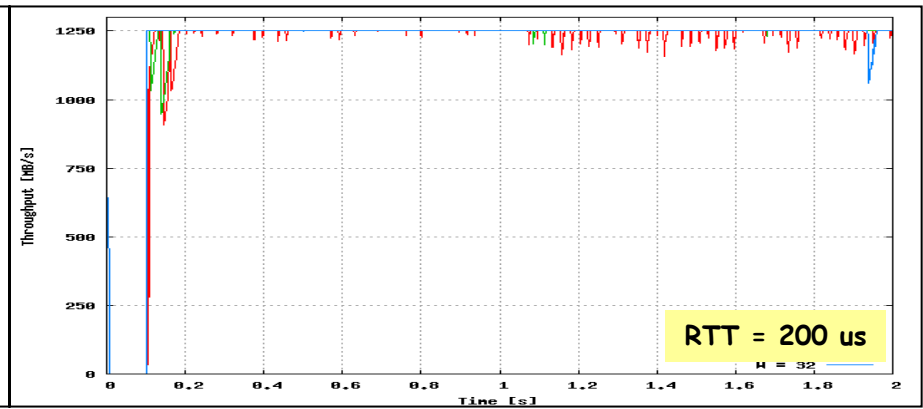
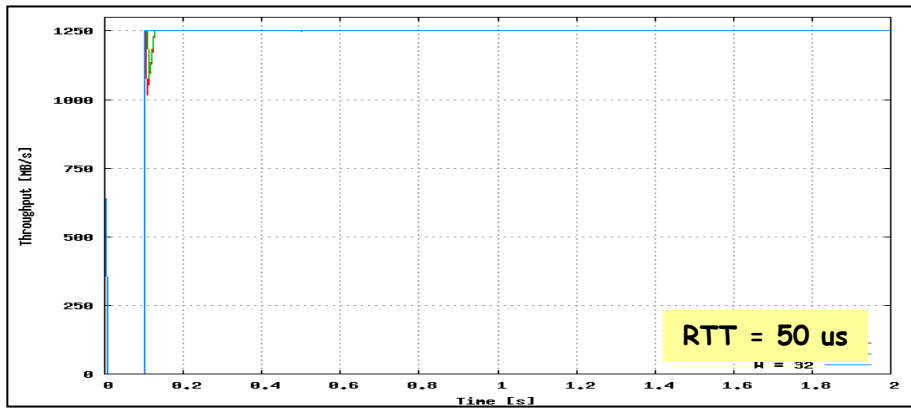
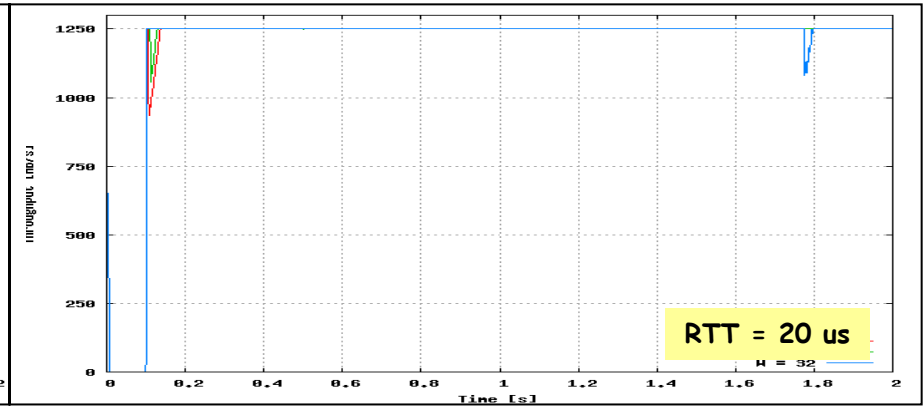
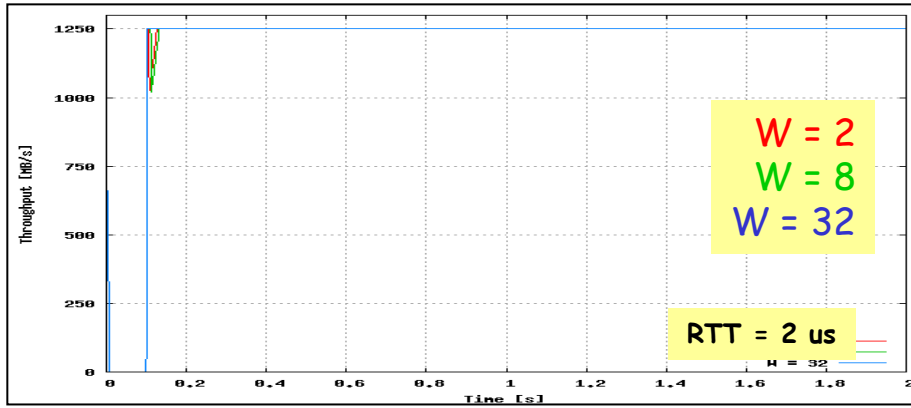

Hot queue length, QCN, Link RTT = 500 us

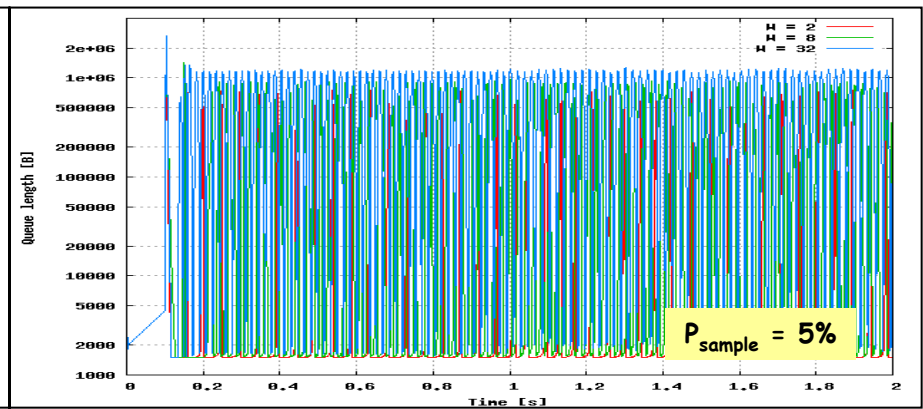
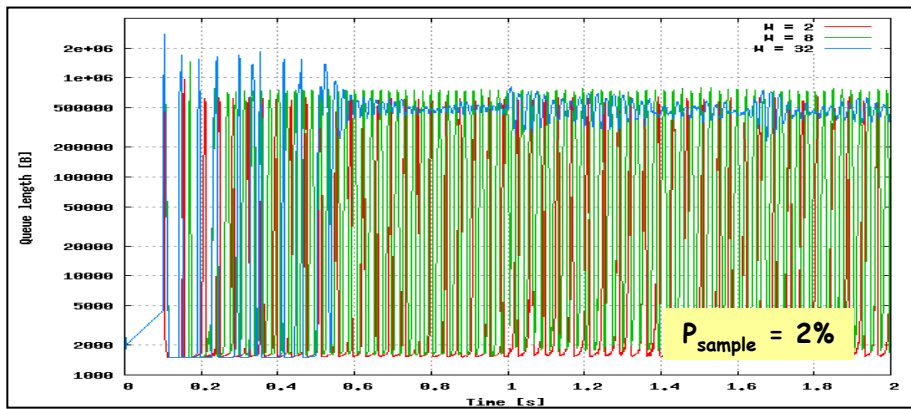
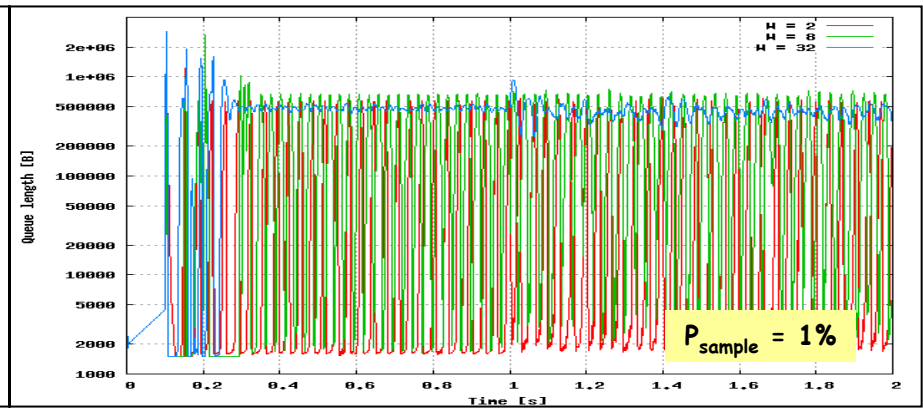
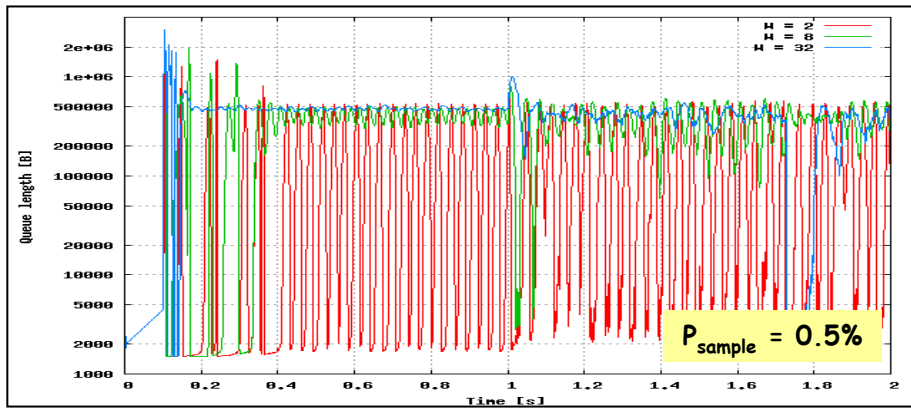
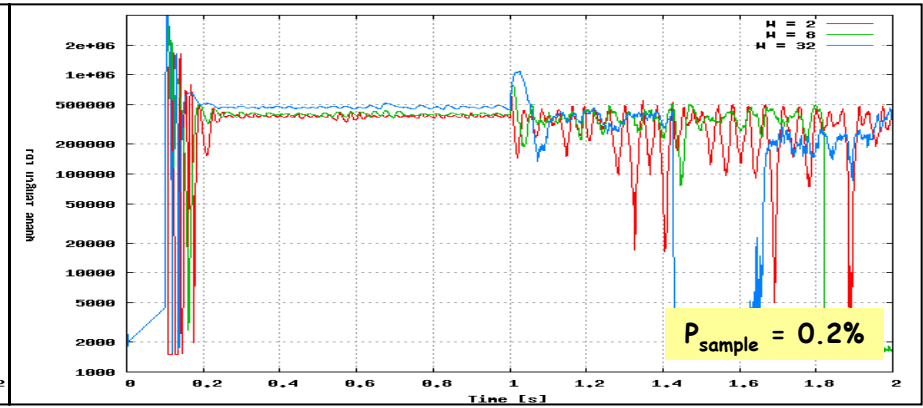
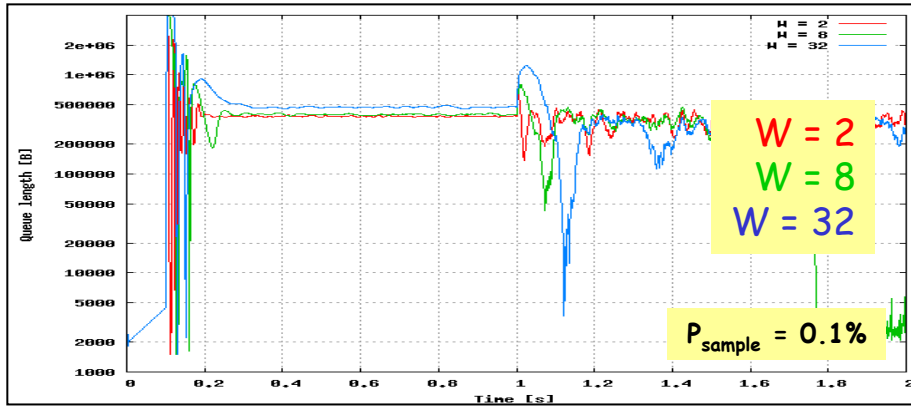

Hot queue length, QCN, $P_{\text{sample_base}} = 1\%$, with RTT filtering

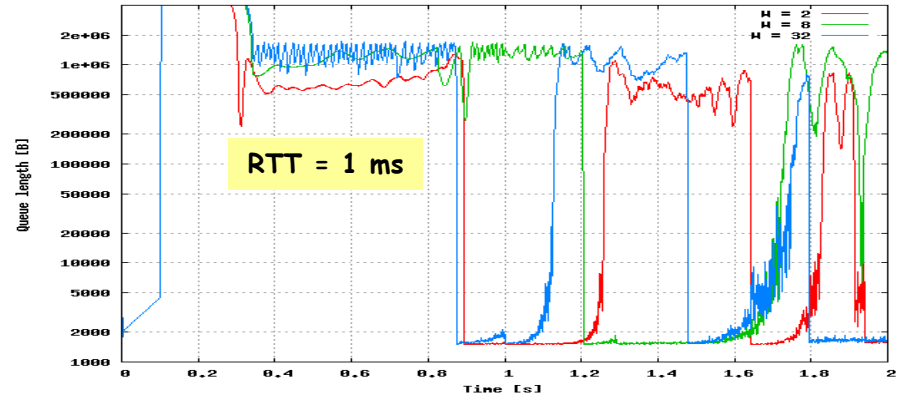
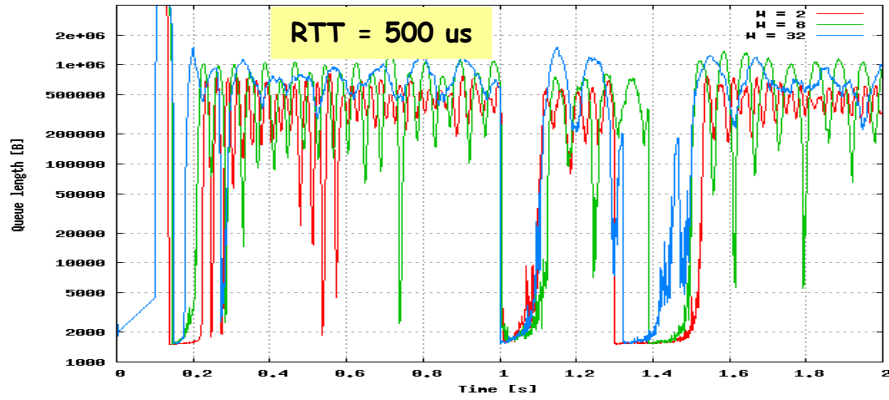
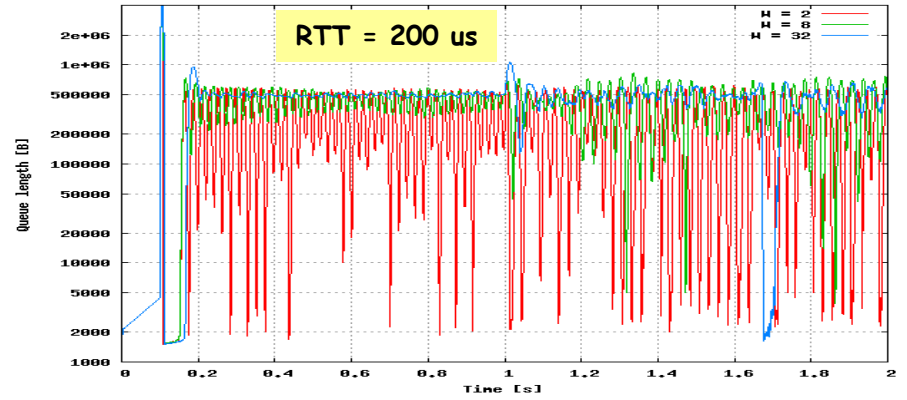
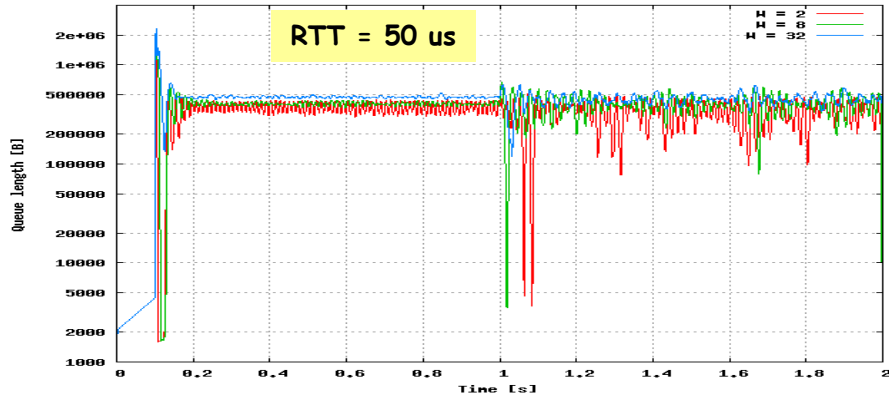
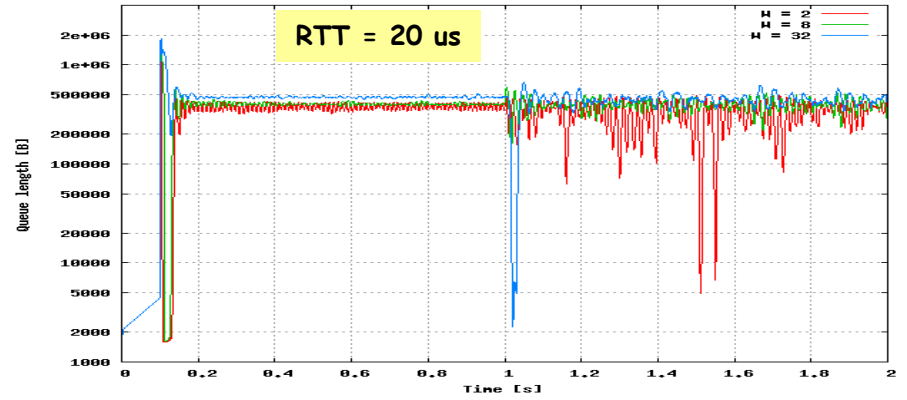
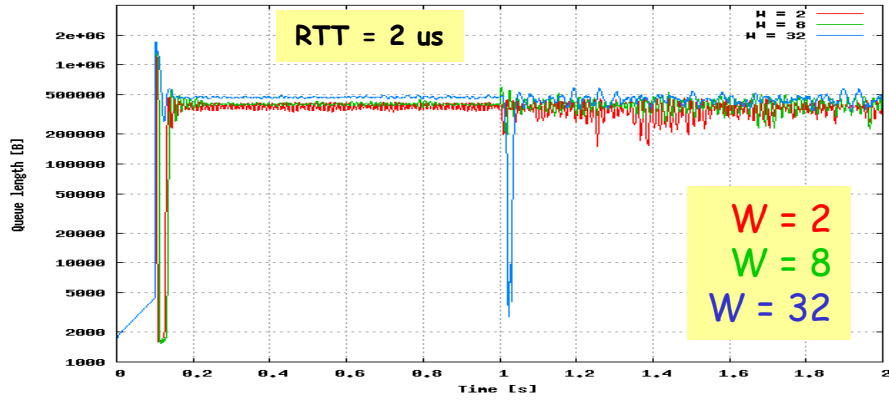

Hot port throughput, QCN, $P_{\text{sample_base}} = 1\%$, with RTT filtering

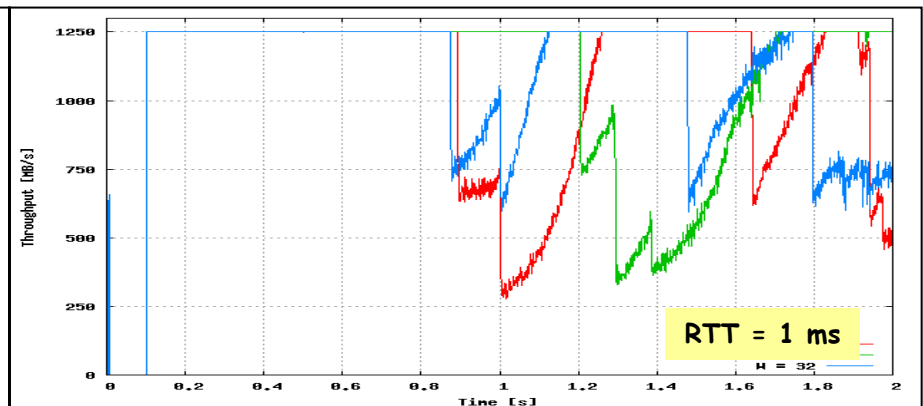
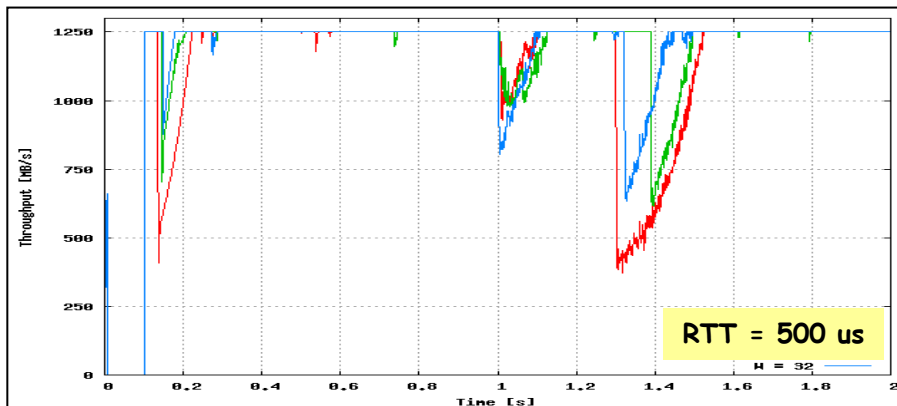
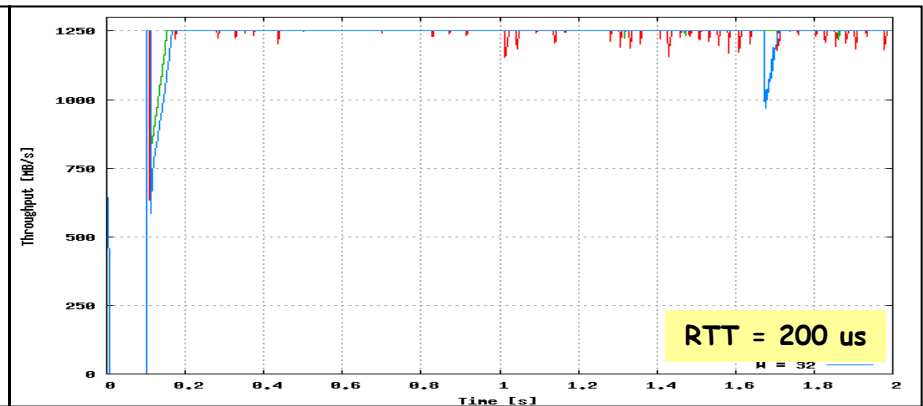
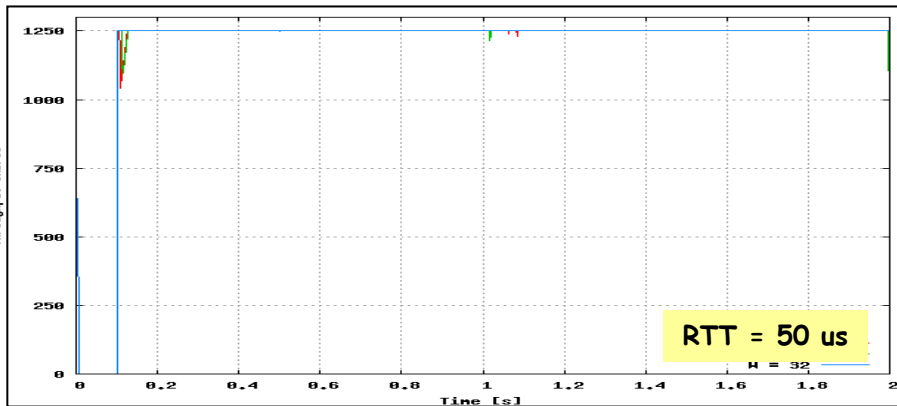
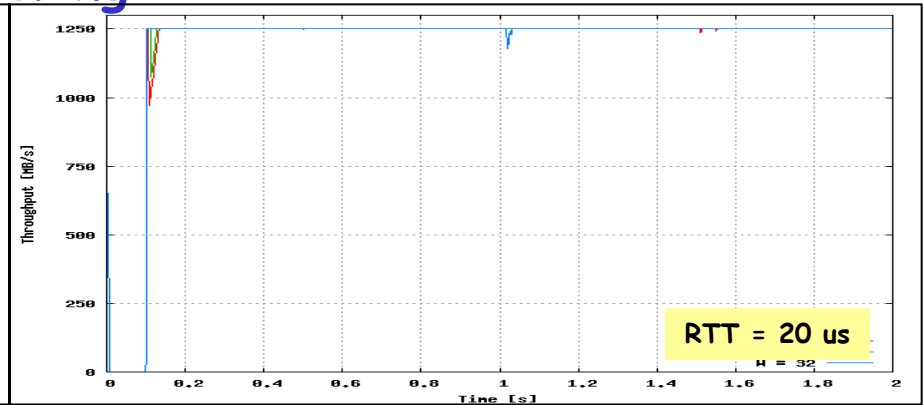
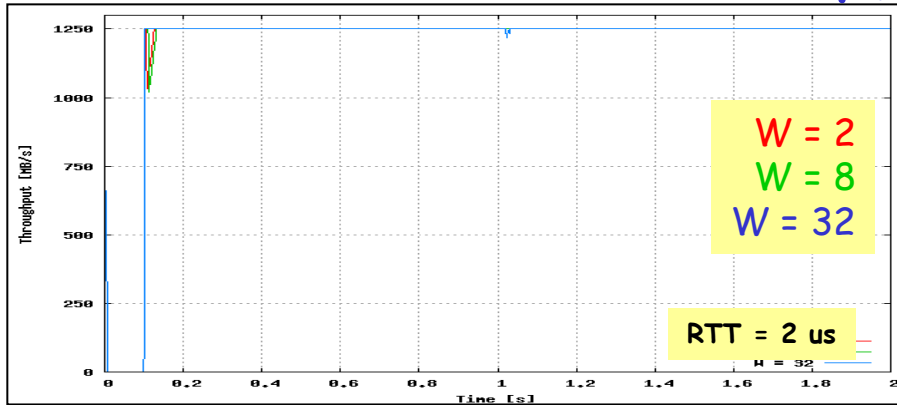

Hot queue length, ECM, $P_{\text{sample}} = 1\%$

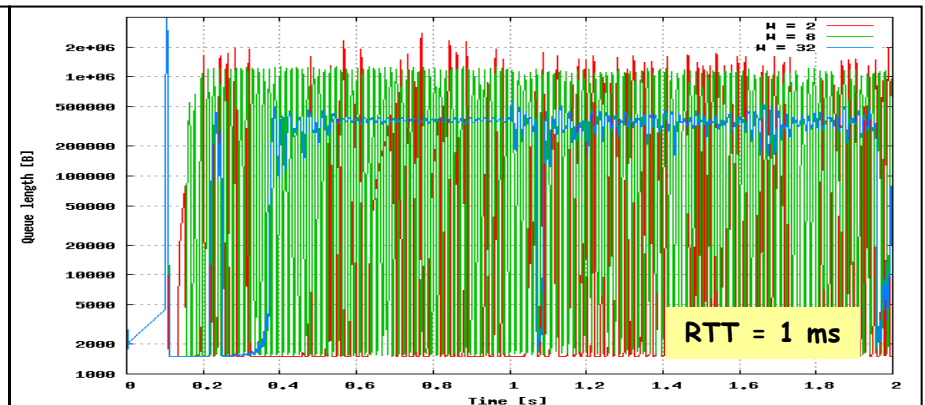
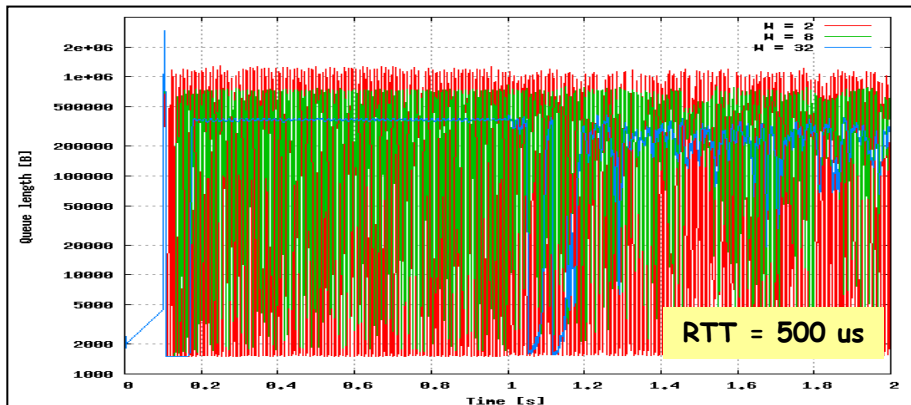
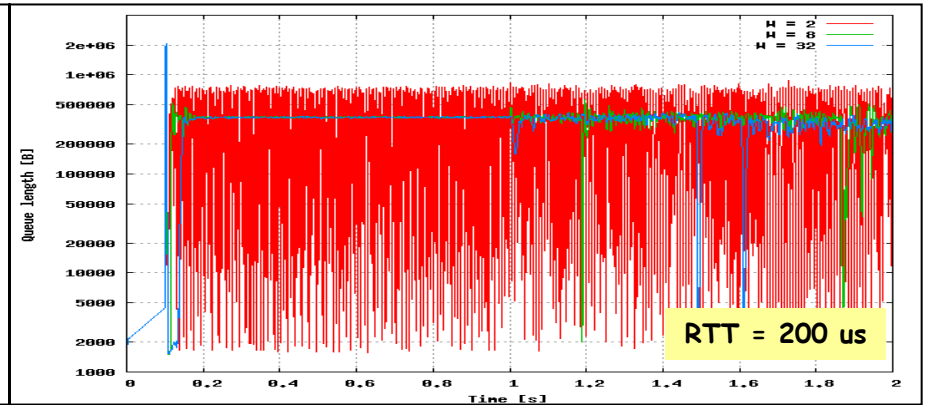
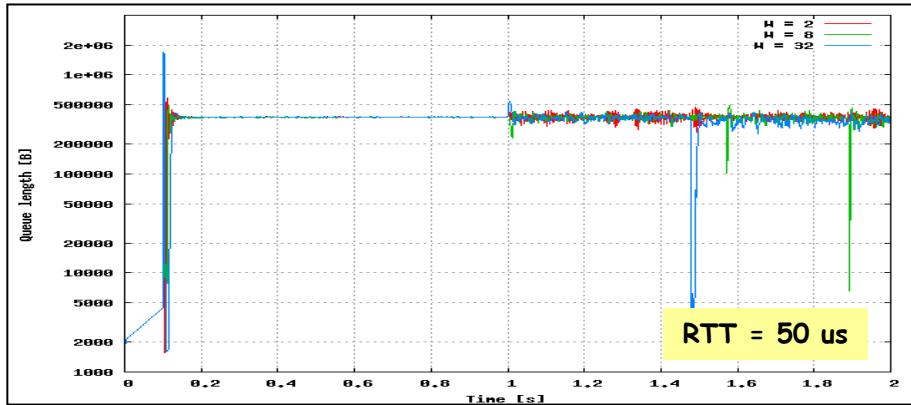
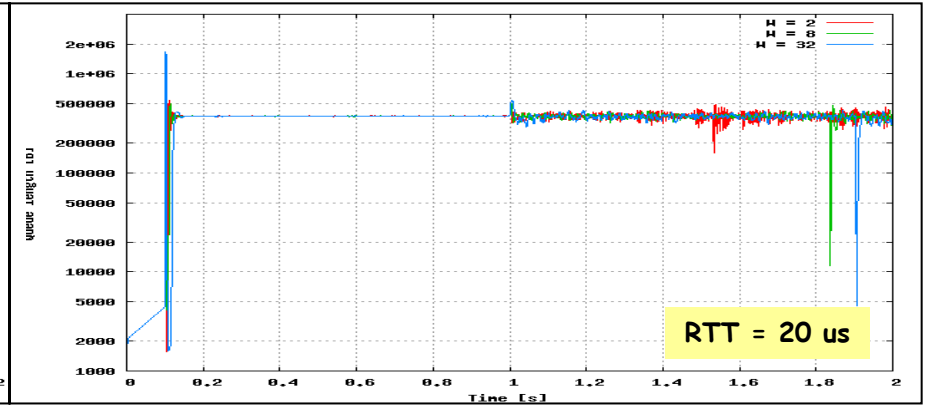
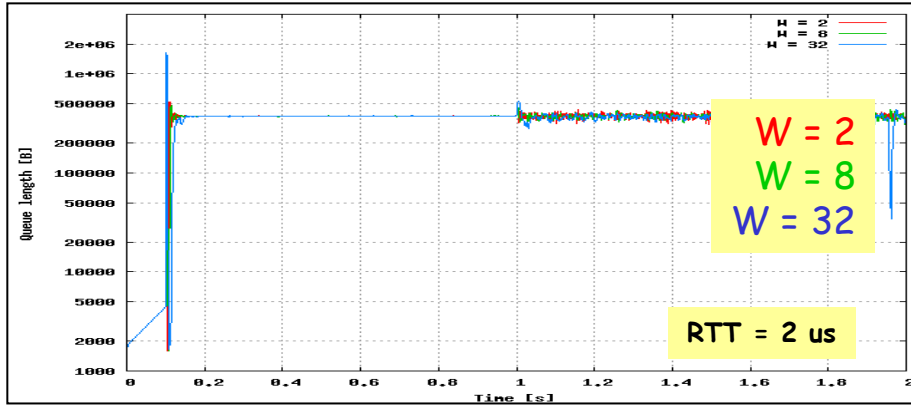

Hot port throughput, ECM, $P_{\text{sample}} = 1\%$

