

Why an additional Shaper

Marcel Kiessling
Distributed Embedded Systems

The SIEMENS logo in a bold, teal, sans-serif font.

UNIVERSITÄT PADERBORN
Die Universität der Informationsgesellschaft

- ✧ Recap: Industrial Requirements for Latency
 - ✦ Different Application requirements regarding Latency

- ✧ Sources of Latency
 - ✦ Reasons for the special treatment of Streams

- ✧ Summary

Industrial Automation Applications

Within industrial we have to differentiate two Systems:

- **Closed Systems**

Typical used for “Closed-Loop-Applications” like motion control system

- ✦ One **network for one application** – this application is fixed
- ✦ Fix topology – adapted to application
- ✦ *Guaranteed QoS & guaranteed low latency*
 - *Highly Optimized, Static “PCE” case for high performance requirements*

- **Open Systems**

Typical used for “Control-Applications” like assembly lines

- ✦ **Multiple automation applications** share the network
- ✦ *Topology can change when applications are added , changed or removed at runtime*
- ✦ *Multiple Control-Data-Traffic Classes within one network (e.g. multiple transmission periods)*
- ✦ *Guaranteed QoS & guaranteed low latency*
 - *Dynamic use case with multiple flexible traffic classes*

Industrial networks can also consist of one Closed and multiple Open Systems

Recap: Different Applications with different Requirements

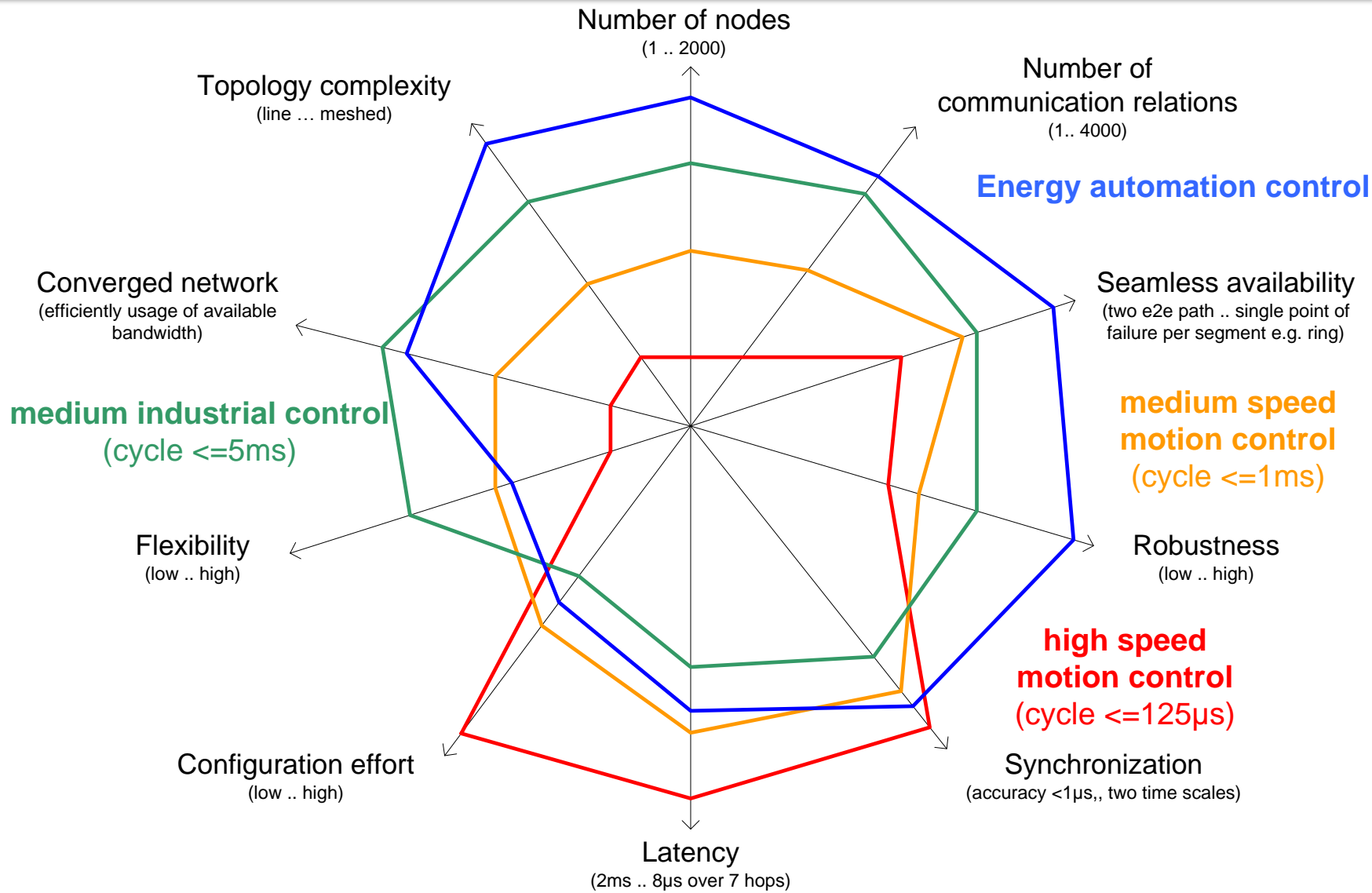

within Hierarchical Automation Networks

PLC: Programmable Logic Controller for input/output data
 DEV: Device for input / output data (sensor / actuator)

- ← · → PLC – DEV communication
- ← · → PLC – PLC communication
- ← · → Real time diagnostic streams
- Ethernet

Plant Level typical

- PLC ↔ Server communication for
 - download PLC configuration / program
 - download prescriptions

and upload production and realtime diagnostic data



Control level typical:

- PLC ↔ PLC / machine – machine communication
- Control-Data-Traffic (CDT)
- Low latency

Field level typical:

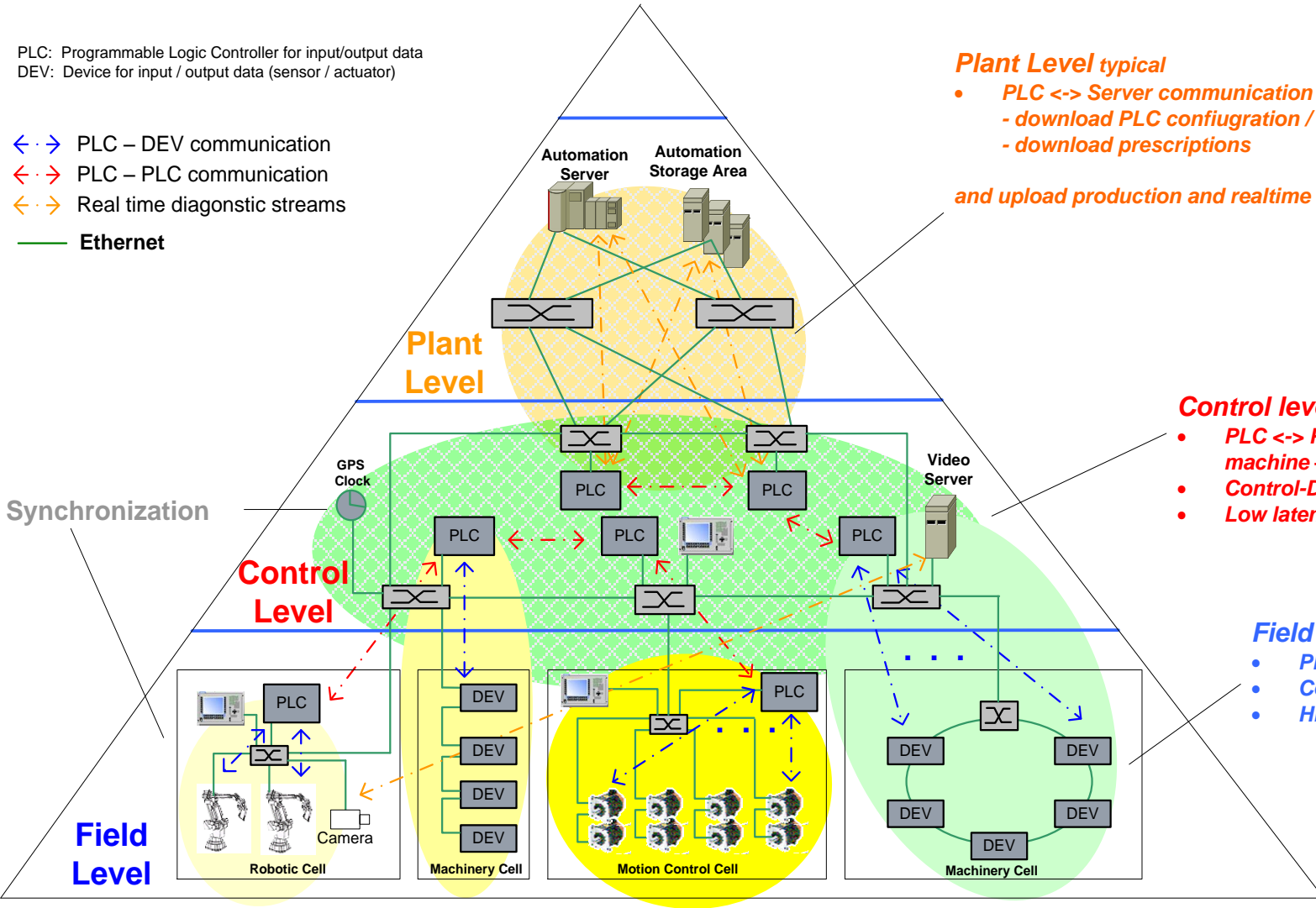
- PLC ↔ DEV
- Control-Data-Traffic (CDT)
- Highest req. on latency

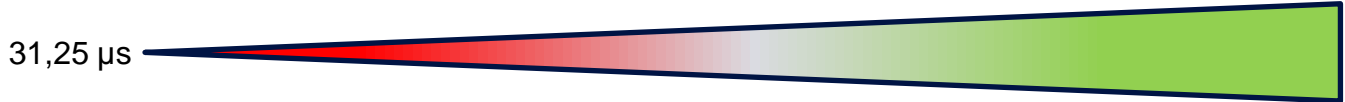

Features	Field-Level	Control-Level	Plant-Level
Link Speed	100 MBit or less	>= 1 GBit	
Max. Stream Bandwidth	< 50%	< 15%	?
Typical Traffic	Control-Data-Streams	slow Control-Data-Streams AV-Streams	AV-Stream for diagnostic and measurement
	... mixed with Synchronization, Network Control and Best-Effort-Traffic		
Transmission cycle (TC)			10ms
Low latency	Closed-Loop-Applications ~ <= 20% of TC Control-Applications ~ TC (<i>Open Systems</i>)	Control-Applications ~ TC (<i>Open Systems</i>)	Application dependent ~ 2.. 10ms
Transmission modes	scheduled and coordinated or scheduled	periodical or scheduled	periodical
Max. frame size			600 byte
Topology	simple topologies Daisy Chains or Rings (e.g. 64 2-Port devices)	more complex topologies e.g. combination with rings, coupled rings, trees and stars, ...	

Features	Field-Level	Control-Level	Plant-Level
Flexibility	Closed Systems with less requirements on flexibility	High requirements on flexibility Add and remove of streams at runtime without any effect on established streams	
Seamless Failover	single Rings	ISIS-PCR for more complex topologies and flexibility	
Path reservation	Closed-Systems with Static path reservation		
	Open-Systems with dynamic path reservation at runtime		
Bandwidth & resource reservation	is required for guaranteed QoS		
	Closed-Systems with static configuration Open-Systems with dynamic configuration	Open-Systems with dynamic configuration	Dynamic configuration

- ✧ Recap: Industrial Requirements for Latency
 - ✦ Different Application requirements regarding Latency
- ✧ Sources of Latency
 - ✦ Reasons for the special treatment of Streams
- ✧ Summary

Maximum effect of all Latency Sources must be considered

AVB / TSN: Avoid or Limit effect for Streams

- ✧ Own class with preferred forwarding
- ✧ Reserved Resources for known Characteristic of Streams

Sources of Latency

- ✧ Loss of Frames – Infinite End-to-End Latency
- ✧ Priority – Traffic from classes with higher priority
- ✧ Priority Inversion – Traffic from classes with lower priority
- ✧ In-Class Interference – Traffic from the same class
- ✧ Bridge Delay and other HW dependent effects
- ✧ others ...

Loss of frames is the worst case latency (e.g. due to congestion)

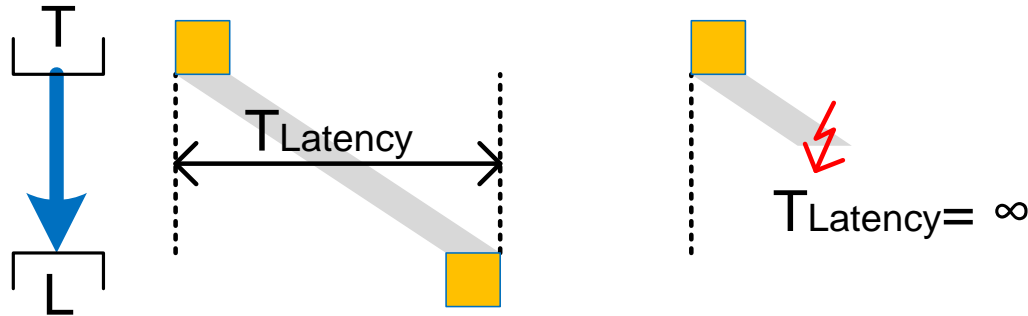

Standardized AVB mechanisms avoid congestion loss

- ✧ Preferred Forwarding - Own Class (with highest Priority) for Streams
- ✧ Reservation of Resources along the path
- ✧ CBSA Shaper to align the Stream with the reserved Resources (special kind of Policing for streams)

Other Frames are transmitted first (higher priority)

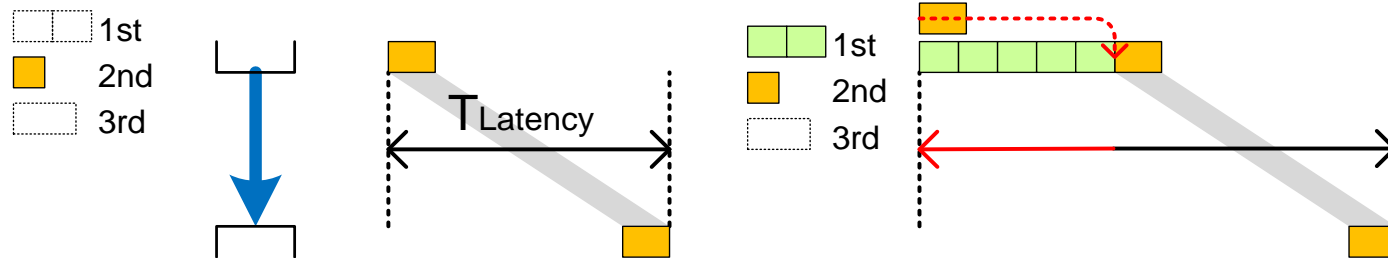

- ✦ **Limited Burst-Size** - to limit the effect of Interference (CBSA in normal operation spreads the traffic to avoid bursts)
- ✦ **Highest Priority** - to avoid higher priorities

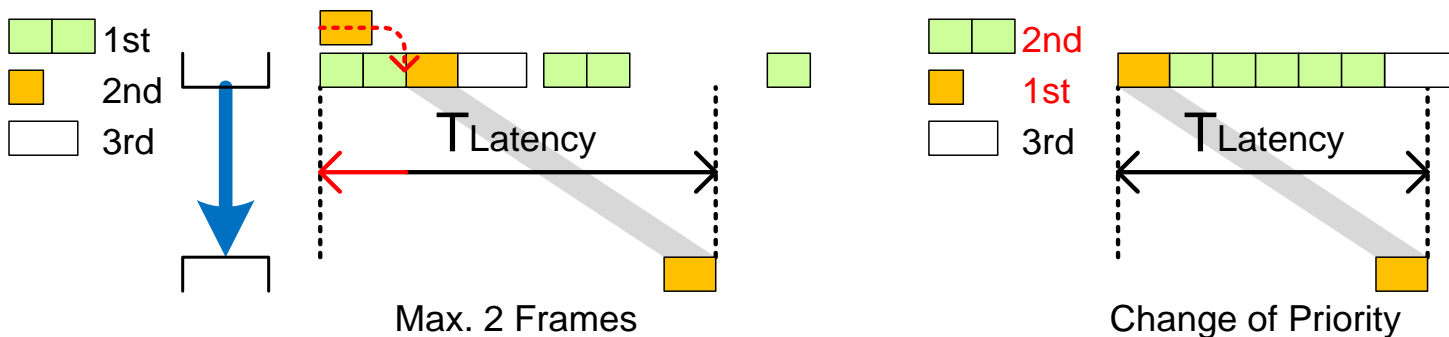

Other Frames are transmitted – busy target Link

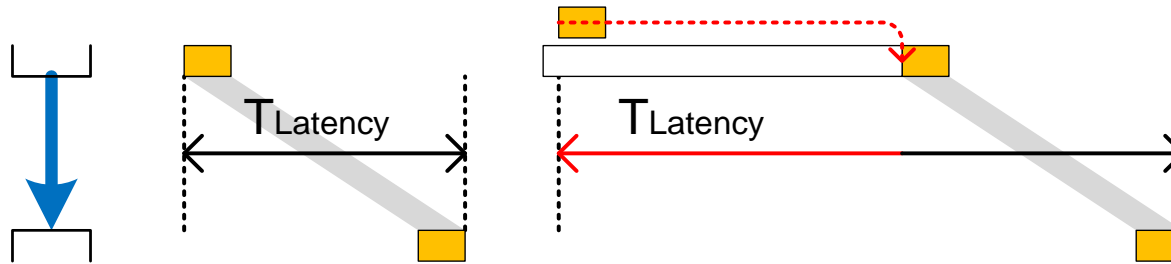

- ✧ **Preemption** - (802.3 br) to shorten the interference
- ✧ **TAS** - (802.1 Qbv) to avoid the Interference
(block the link for other traffic in advance)

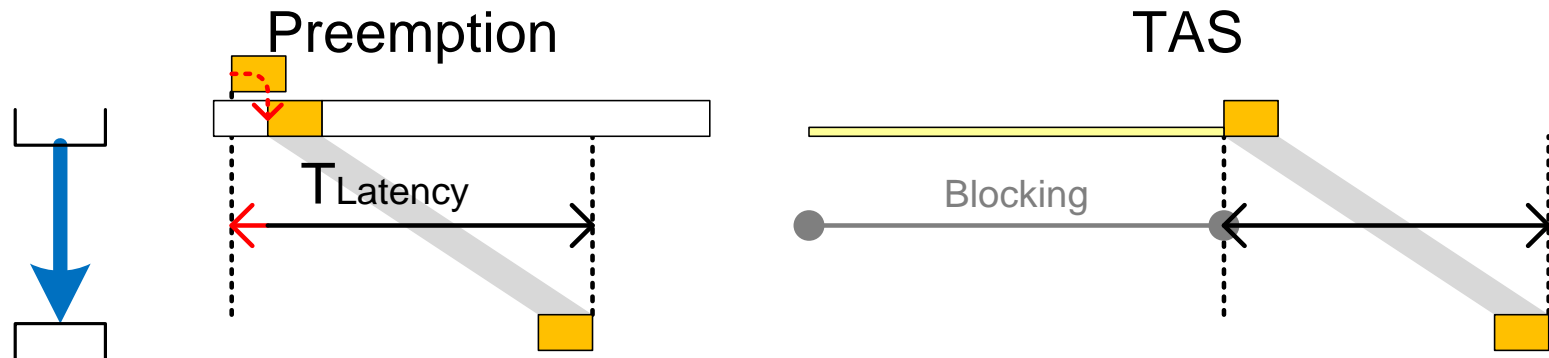

Other Frames of the same class can be transmitted first

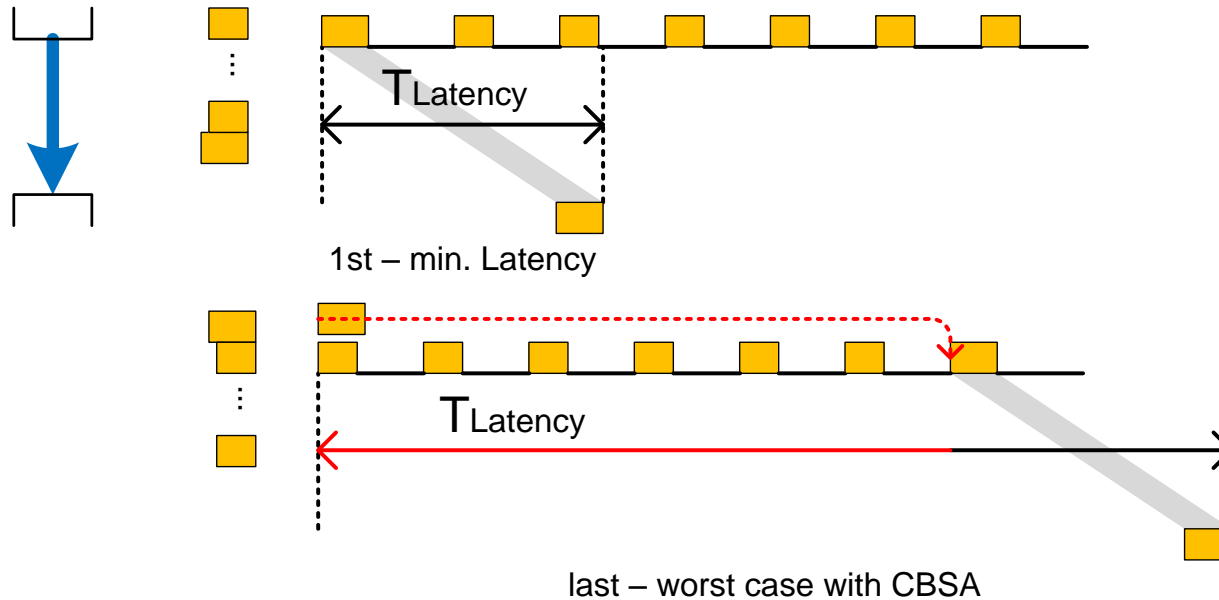

AVB Maximum Latency based on the Worst-Case
(additional **CBSA** latency from spreading between frames)

New **TSN** Shapers to avoid the additional spreading:
UBS / TAS with coordination

✦ **BLS** – Burst Limiting Shaper (*Policer*)

Other Frames of the same class can be transmitted first

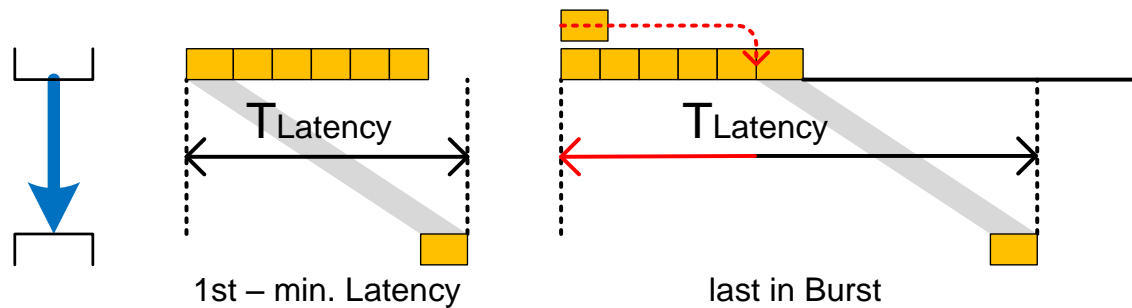

Strict Priority releases all frames in one burst

(Basically Strict Priority in normal operation – robustness for lower traffic classes in **case of errors** by dropping frames)

BLS as Policing to ensure the max. size of a burst

(Limit the size of interference to a maximum amount for lower priorities **in case of an error**)

✧ **UBS** – Urgency based Shaper

Frames are transmitted according to their sub-priority
(Urgency from a connection defines a sub-priority for the class)

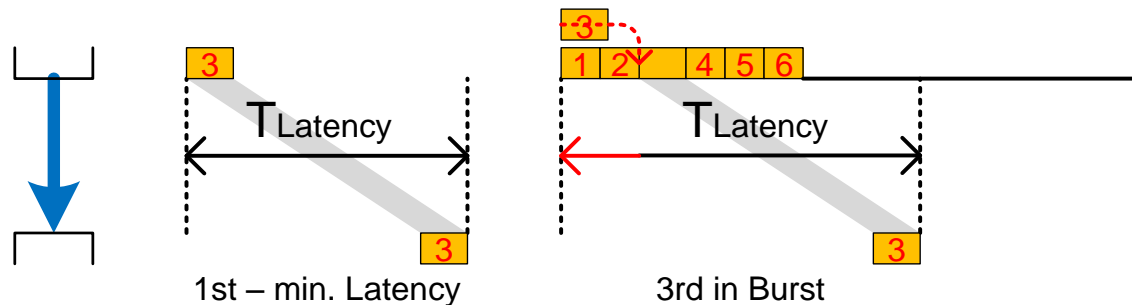

UBS lowers the worst-case for urgent frames

(frames with higher priority are preferred in case of congestion)

Improved UBS to cover automotive and industrial requirements

(e.g. Groups of Streams for scalability)

<http://www.ieee802.org/1/files/public/docs2014/new-tsn-specht-ubs-status-update-0514-v01.pdf>

✦ **Coordination** of transmit times for Streams

Frames are transmitted according to a planned schedule
(Interference can be avoided by shift of transmit time)

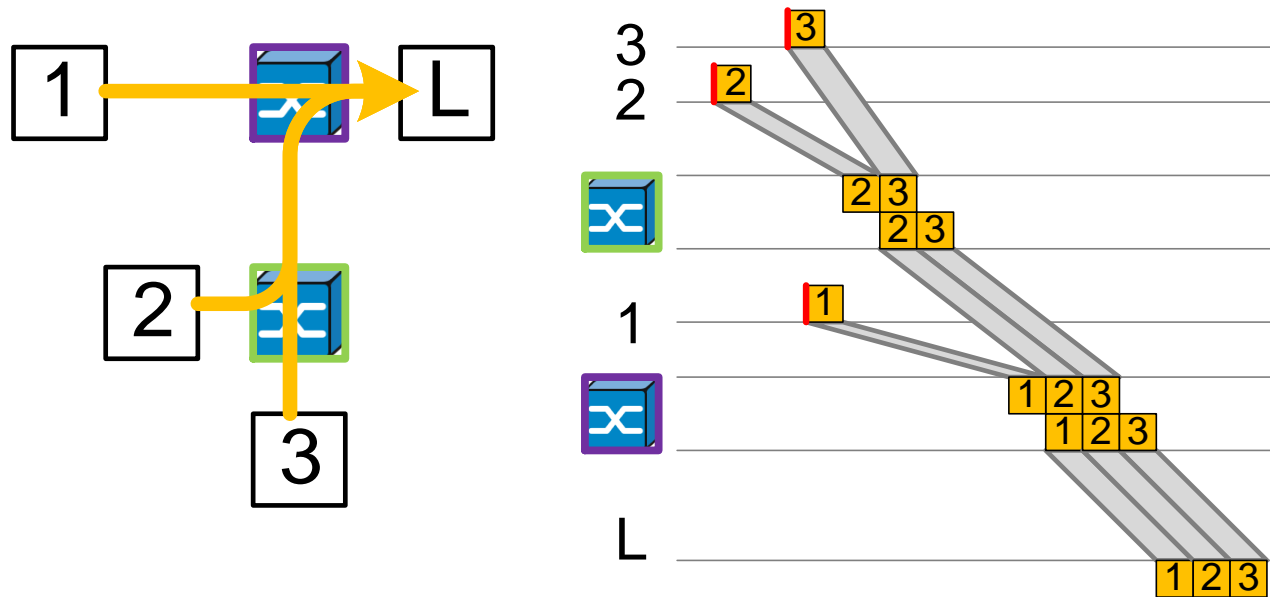

Can be combined with other mechanism

e.g. **TAS** can be used to avoid interference (see Priority Inversion)

Jitter is the variation of the Delay, End-to-End (E-2-E) Jitter or Delay must be accumulated along the complete path

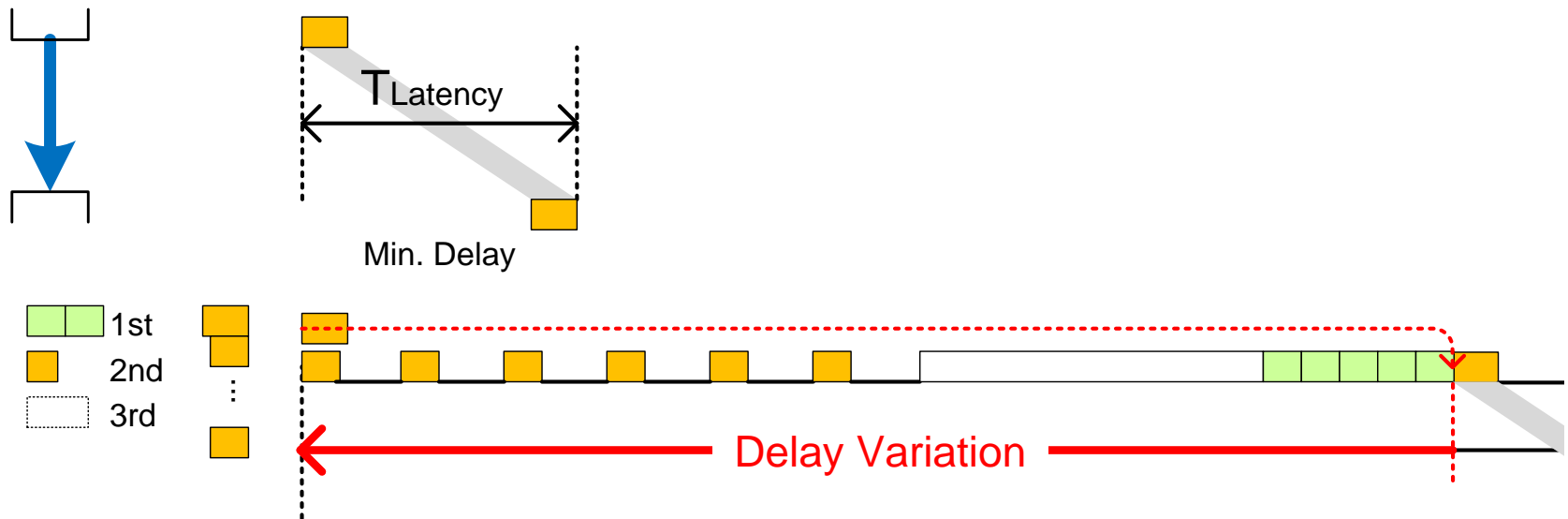

Worst-case for 1 Link

Applications must handle Latency between min. and max.

CB avoids loss of frames in case of a network failure (∞ -Latency)

TAS avoids /**Preemption** limits Jitter from lower-class interference

Jitter can be lowered by increasing the min. Latency

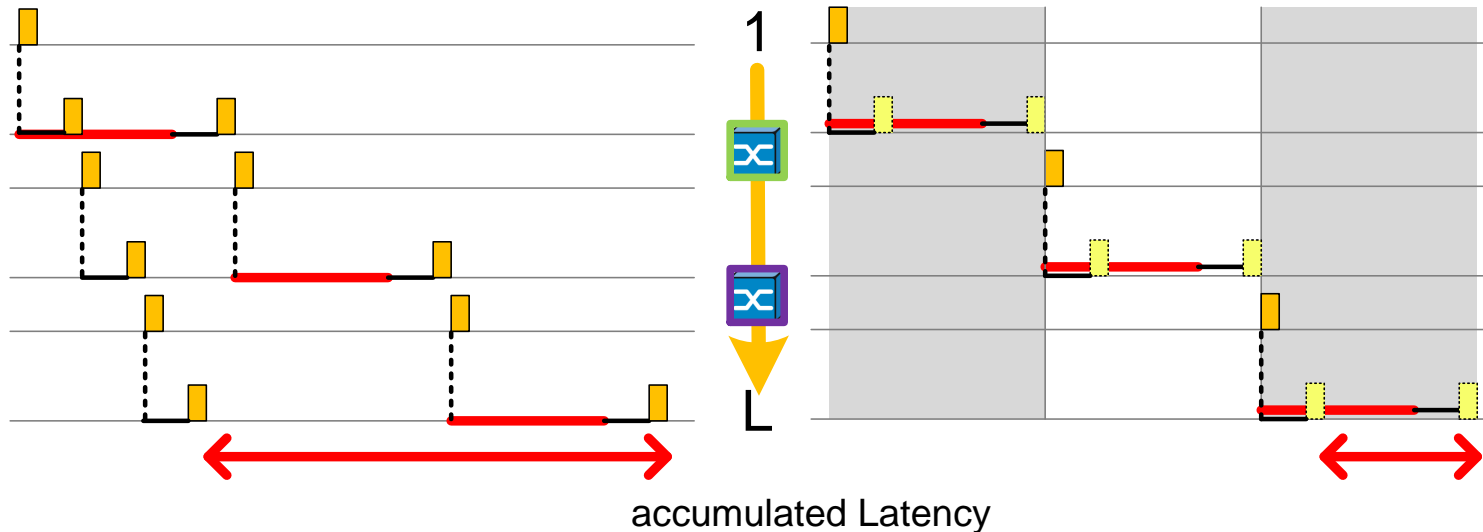

Applications must handle a smaller possible arrival windows

SQF can be combined with other mechanisms

- ✧ Recap: Industrial Requirements for Latency
 - ✦ Different Application requirements regarding Latency

- ✧ Sources of Latency
 - ✦ Reasons for the special treatment of Streams

- ✧ Summary

High Priority for lower latency

Reservation to avoid congestion causing loss of frames

CB can avoid loss of frames in case of a failure

Coordination to influence congestion and in-class interference

Preemption to lower Frame Interference

(improve bandwidth usage in case of TAS)

Shaper influence Delay and Jitter

Low Latency and Shapers are converse requirements

Policing for robustness in case of failures

(robustness in case of failures – **no delaying in normal operation**)

Shaper influence Delay and Jitter:

- ✧ **BLS** see *policing* – requirements considered in UBS
- ✧ **UBS** for low latency with limited In-class interference (sub-priority dependent worst-case)
- ✧ **TAS** to avoid Jitter caused by Frame Interference
- ✧ **SQF** to minimize Jitter by increasing min. Latency (*replacement for CBSA?*)
<http://www.ieee802.org/1/files/public/docs2014/new-tsn-mjt-peristaltic-shaper-0114.pdf>

Features	Field-Level	Control-Level	Plant-Level
Which predominant requirement?	Closed Systems: TAS with Coordination for lowest latency or Open Systems: Flexibility (with UBS)	Flexibility (with UBS)	Flexibility (with UBS) or SQF for Low-Jitter AV Streams

Current Status:

TAS for closed systems (802.1 Qbv)

UBS and **SQF** are currently “homeless” (no PAR)

Policing ... requirements from automotive and industrial automation for stability

Some Sources of Latency and Jitter

<http://www.ieee802.org/1/files/public/docs2013/bv-kiessling-Some-sources-of-Latency-and-Jitter-0513-v01.pdf>

How Many Transmission Selection Algorithms Do We Need?

<http://www.ieee802.org/1/files/public/docs2013/new-tsn-boiger-new-shaper-0513.pdf>

Why an additional Shaper?

<http://www.ieee802.org/1/files/public/docs2013/new-tsn-kiessling-Why-an-additional-Shaper-0313-v3.pdf>