

Project	IEEE 802.16 Broadband Wireless Access Working Group < http://ieee802.org/16 >
Title	802.16n System Requirements Document including SARM annex
Date Submitted	2011-01-13
Source(s)	Tim Godfrey Chair, GRIDMAN TG EPRI tim.godfrey@ieee.org
Re:	
Abstract	This document captures functional requirements of the 802.16n amendment, including the System Architecture Reference Model
Purpose	To serve as a basis for further development by GRIDMAN SG
Notice	<i>This document does not represent the agreed views of the IEEE 802.16 Working Group or any of its subgroups.</i> It represents only the views of the participants listed in the “Source(s)” field above. It is offered as a basis for discussion. It is not binding on the contributor(s), who reserve(s) the right to add, amend or withdraw material contained herein.
Release	The contributor grants a free, irrevocable license to the IEEE to incorporate material contained in this contribution, and any modifications thereof, in the creation of an IEEE Standards publication; to copyright in the IEEE’s name any IEEE Standards publication even though it may include portions of this contribution; and at the IEEE’s sole discretion to permit others to reproduce in whole or in part the resulting IEEE Standards publication. The contributor also acknowledges and accepts that this contribution may be made public by IEEE 802.16.
Patent Policy	The contributor is familiar with the IEEE-SA Patent Policy and Procedures: < http://standards.ieee.org/guides/bylaws/sect6-7.html#6 > and < http://standards.ieee.org/guides/opman/sect6.html#6.3 >. Further information is located at < http://standards.ieee.org/board/pat/pat-material.html > and < http://standards.ieee.org/board/pat >.

2

3

4

5

6

7

8

9

10

11

1
2
3
4
5
6
7
8
9
10
11
12
13
14
15
16
17
18
19
20
21
22
23
24
25
26
27
28
29
30
31
32
33
34

1 Overview

The 802.16n amendment shall be developed in accordance with the P802.16 project authorization request (PAR) [1] with its accompanying Five Criteria Statement.

The standard shall be developed as an amendment to 802.16. The resulting standard shall fit within the following scope:

“This amendment specifies protocol enhancements to the IEEE 802.16 MAC for enabling increased robustness and alternate radio path establishment in degraded network conditions. Limited OFDMA PHY extensions are included for enabling operation with radio path redundancy and direct communication between subscriber stations. Also mobile base stations and mobile relay stations are supported. Support for enabling application specific specialized security suites is also provided.”

With the explanatory note:

“Operation in licensed, unlicensed and lightly licensed spectrum bands below 6 GHz with means and mechanisms to coexist with other radio access technologies (RATs) is supported.”

This document represents the high-level system requirements for the 802.16n amendment. All content included in any draft of the 802.16n amendment shall meet these requirements. This document, however, shall be maintained and may evolve. These system requirements embodied herein are defined to ensure competitiveness of the amended standard against other mobile broadband radio access technologies in those areas defined by the PAR and Five Criteria Statement. These system requirements also call for significant gains and improvements relative to the preexisting IEEE 802.16 system that would justify the creation of the amendment. To accelerate the completion and evaluation of the standard, to improve the clarity and reduce complexity of the standard specification, and to further facilitate the deployment of new systems, the number of optional features should be minimized.

2 References

1. IEEE P802.16n PAR and 5C in 80216gman-10_0018r2.doc

3 Definitions

The definitions below have been agreed in the PAR

Degraded Network	The failure of one or more 802.16 network infrastructure nodes or network connectivity
Robustness	The capability of the network to withstand and automatically recover from degradation to provide the required availability to support mission critical applications (essential to the core function of society and the economy). E.g. the ability to recover from a single point of failure
Mobile Base Station	A base station which is capable of maintaining service while moving
Radio Path Redundancy	The ability to provide alternative paths between base stations, relay stations, and subscriber stations
<i>Other definitions</i>	
HR-MS	A subscriber station that complies with the requirements for subscriber stations in this amendment
HR-BS	A base station that complies with the requirements for base stations in this amendment

HR-RS	A relay that complies with the requirements for relays in this amendment
HR-network	A network whose stations comply with their respective HR requirements in this amendment
HR-station	An HR-MS, HR-BS or HR-RS.
Infrastructure station	An HR-BS or HR-RS

1
2
3
4
5

4 Abbreviations and Acronyms

SPOF	Single point of failure
HR	High Reliability (e.g. as in HR-MS)

6
7

5 General Requirements

5.1 Backward Compatibility

HR-Network shall be backward compatible with the WirelessMAN-OFDMA or WirelessMAN-Advanced Air Interface.

5.2 Complexity

IEEE 802.16n amendment should minimize complexity of the architecture and protocols and avoid excessive system complexity. It should enable interoperability of access networks, support low cost devices and minimize total cost of ownership.

5.3 Services

IEEE 802.16n should support services that require a higher degree of assurance of maintaining sufficient connectivity than can be provided by IEEE 802.16 legacy systems. Examples of such services can be found in PPDR (Public Protection and Disaster Recovery) and M2M (Machine to Machine) communication networks for utility monitoring and control.

5.4 Operating Frequencies

The HR-Network shall be specified to allow operation in all radio frequencies where 802.16 operates. The HR-Network shall also be specified to allow operation in unlicensed and lightly licensed spectrum bands below 6 GHz with means and mechanisms to coexist with other radio access technologies (RATs). As an example for frequencies used for PPDR, the following frequency bands have been identified by WRC 2003 (RESOLUTION 646 (WRC-03): Public Protection and Disaster Relief, The World Radiocommunication Conference (Geneva, 2003).)

- For region 1
- 380-385 MHz
 - 390-395 MHz
- For region 2
- 746-806 MHz
 - 806-869 MHz

- 1 ● 4,940-4,990 MHz
2

3 For region 3

- 4 ● 406.1-430 MHz
5 ● 440-470 MHz
6 ● 806-824 MHz
7 ● 851-869 MHz
8 ● 4,940-4990 MHz
9 ● 5,850-5,925 MHz

10

11 One more example is 170-205 MHz that is specified by Japan Ministry of Internal Affairs and Communica-
12 tions (MIC) in 2010 for public broadband applications in Japan”¹
13

14 **5.5 Operating bandwidths**

15 HR-Network shall support the operating bandwidths of the WirelessMAN-OFDMA or WirelessMAN-
16 Advanced Air Interface. This bandwidth may be supported by single or multiple RF carriers.

17

18 Other bandwidth may be considered as necessary to meet the government or operator requirements.]
19

20 **5.6 Duplex schemes**

21 The HR-Network shall be specified to support TDD and FDD.
22
23

¹ Japan Ministry of Internal Affairs and Communications (MIC) “The Ordinance Regulating Radio Equipment”
(ORE) Article 49-31 (in Japanese)

1 **6 Functional Requirements**

2 HR-Network devices shall comply with all Advanced Air Interface or 802.16 OFDMA functional require-
3 ments unless indicated below. Additional functional requirements are indicated in this section.

4 **6.1 Requirements related to construction and maintenance of network**

5 This section contains requirements for IEEE 802.16n related to construction and maintenance of the net-
6 work. These requirements are intended to address multi-mode operation, link existence, infrastructure
7 SPOF immunity, link reliability, mobility, security, and coexistence.

8 **6.1.1 Requirements related to multi-mode operation**

9 Ability to dynamically change roles shall be included as defined in this clause.

10 6.1.1.1 Relay function for HR-BS

11 HR-Network shall support HR-BS communication with another HR-BS in order to support the relaying
12 function to provide continuous network connectivity.

13 6.1.1.2 Relay function for HR-MS (RS Mode)

14 HR-Network shall support an HR-MS changing its role to relay data between other mobile or relay sta-
15 tions and a functioning HR-BS or HR-RS

16 6.1.1.3 Base Station function for HR-MS (BS Mode)

17 HR-Network may support an HR-MS to change its role to serve as a base station.

18 **6.1.2 Requirements related to infrastructure SPOF immunity**

19 An HR-network shall be able to recover from any single point failure in any of its infrastructure nodes (i.e.
20 all nodes excluding the subscriber station) or any of its radio links.

21 6.1.2.1 Standalone networks

22 HR-Network shall provide local connectivity to the HR-MSs within the coverage of the HR-BS without HR-
23 BS's connectivity to the backbone network.

24 When the HR-BS loses the backbone connection, the established service flow between HR-MSs within
25 the coverage of the HR-BS should be maintained.

26 6.1.2.2 Multi-hop relaying

27 HR-Network shall provide at least a 2 hop relaying function.

28 6.1.2.3 HR-RS Sourcing and Sinking of Data

29 HR-Network shall support local source and sink of data at the HR-RS

30 **6.1.3 Requirements related to link existence and reliability**

31 6.1.3.1 MS to MS Direct Communication

32 HR-MS shall provide direct communication i.e. the origination and termination of the data are at the HR-
33 MS. Association establishment procedure of an HR-MS to another HR-MS shall be supported.

34 6.1.3.1.1 Single hop

35 HR-MS shall support communication of user data and control signaling between an HR-MS and one or
36 more HR-MSs that are 1-hop away.

37 6.1.3.1.2 Two-hop

38 HR-MS shall support forwarding of user data and control signaling between an HR-MS and one or more
39 HR-MSs.
40
41

1 6.1.3.2 HR-MS forwarding to network

2 HR-MS forwarding is defined as the case where the origination and termination of data are at the HR-MS
3 and network respectively and vice versa.

4 HR-Network shall support HR-MS forwarding of user data and control signaling between HR-MS and HR-
5 BS and between HR-MS and HR-RS. The control signaling and data transmission for the HR-MS to HR-
6 MS direct link shall at least be capable of operating within the frequency band that the HR-BS operates.
7 An association establishment shall be supported.

8 6.1.3.3 Path discovery

9 HR-Network shall support neighbor and path discovery between HR-MSs as well as between HR-MS and
10 HR-Network infrastructure stations.

11 Path discovery can be accomplished with or without network support.

12 6.1.3.4 Path Management

13 HR-Network shall support establishment and maintenance of alternative paths to support fast recovery in
14 the event of disruption; for example, encountering intermediate HR-MS failure or movement.. HR-Network
15 shall provide the capability to choose the most reliable path.

16 6.1.3.5 Local Forwarding for RS and BS

17 HR-Network should allow local forwarding, which allows one HR-MS to communicate to one or more HR-
18 MSs via infrastructure station without going through the backhaul.

19 **6.1.4 Requirements related to security**

20 The HR-Network topology shall not degrade the security performance achieved with WirelessMAN-
21 OFDMA or WirelessMAN-Advanced Air Interface in hierarchical network topology.

22 6.1.4.1 Security procedures for HR-Network

23 HR-Network shall support secure communication and session establishment among HR-stations, and
24 between HR-stations and external AAA-servers.

25 6.1.4.1.1 Network aided mutual authentication of HR-MS and data security

26 HR-MSs shall be able to establish a security association with each other. A security server may be used
27 to facilitate the establishment of security associations.

28 6.1.4.1.2 Autonomous (limited) mutual authentication of HR-MS and data security for direct 29 communication

30 HR-MS shall be able to mutually authenticate themselves without access to a security server.
31 HR-MS shall be able to establish encrypted communication without access to a security server.

32 6.1.4.1.3 Security requirements for HR-Network nodes acting as relays

33 HR-station that functions as a relay shall forward security related messages between other HR-station
34 and a security server, both during security association establishment and ongoing communications.

35 6.1.4.2 Multicast key Management

36 HR-Network shall provide the security architecture that provides a group of HR-MSs with authentication,
37 authorization, encryption and integrity protection.

38 HR-Network shall provide multicast key management for the group of HR-MSs. The key shared within the
39 group should be distributed securely and efficiently. HR-Network should support the group signaling
40 procedure using multicast transmission for multicast key management efficiently.

41 **6.1.5 Coexistence requirements**

42 6.1.5.1 Operation in unlicensed and lightly licensed bands

43 HR-Stations shall comply with regulators' respective requirements for operation in unlicensed and lightly
44 licensed spectrum.

1 6.1.5.2 Support for Multi-carrier operation in different licensing regimes

2 The HR-Network shall support multicarrier operation in licensed, unlicensed and lightly-licensed licensing
3 environments.

4 An HR-MS that supports MC operation in different licensing environments shall be able of operating in all
5 three types of spectrum at the same time.

6 6.1.5.3 Interference Mitigation

7 HR-Network shall support mechanisms which enable acceptable operation in the presence of co-channel
8 interference among HR-stations within the same geographical area.

9

10 **6.2 Requirements related to Services provided on network**

11 **6.2.1 Enhancements to Unicast and Multicast communication**

12 HR-Network shall provide optimized MAC protocols for unicast and multicast transmission to support ap-
13 plications of two-way communications such as Push to Talk (PTT) service among a group of HR-MS.

14 Examples of applications to be used in PTT service include:

- 15 - audio (e.g., speech, music)
- 16 - video
- 17 - still image
- 18 - text (formatted and non-formatted)
- 19 - file transfer

20 **6.2.2 High reliability control and reporting**

21 The HR-network shall provide MAC enhancements to support high reliability latency intolerant control
22 and reporting.

23

24 **6.2.3 Priority Access Service**

25

26 The HR-Network MAC shall be able to support a priority access service for ETS (Emergency Telecom-
27 munications Services) and other priority applications

28

29 **6.2.4 Uplink Heavy Data Service**

30 The HR-Network MAC shall support uplink heavy data service for supporting uplink video streaming for
31 surveillance, PPDR and other applications.

32

33 **7 Performance Requirements**

34

35 **7.1 Message delivery reliability and latency**

36

37 Message delivery reliability is defined as the probability of success in delivering a message within a spe-
38 cific time from MAC SAP of HR-MS to MAC SAP of HR-BS and vice versa. It includes any MAC and PHY
39 signaling that is required for the data transfer.

40

41 When used for stationary devices, (e.g. for Smart Grid applications) HR-Network shall support message
42 delivery reliability of at least 99.5% with latency not to exceed 100ms, 99.7% with latency of 200ms and
43 99.8% with latency of 400ms.

44

45 These requirements apply to not more than 2 hops, in an operationally loaded network. The latency does
46 not include any time required for the repair in case of a degraded network.

47

1 **7.2 Multicast Performance**

2 **7.2.1 Multicast VoIP Capacity**

3 The multicast VoIP capacity is at least 7.1 multicast connections/sector/MHz.

4

5 **7.2.2 Multicast connection setup time**

6 Multicast connection setup time is the required time for HR-MS to establish a multicast connection with a
7 group of users. The value of multicast connection setup time is only the transmission time on the MAC
8 layer signaling procedures excluding upper layer signaling procedures. The maximum multicast connec-
9 tion setup time is 150 ms in a single hop.

10

11

12

13

14

1 8 Annex: System Architecture Reference Model (SARM)

2 8.1 Overall Network Architecture

3 The Network Reference Model (NRM) shown in Figure 1 is a logical representation of the network
 4 architecture. The NRM identifies functional entities and reference points over which interoperability is
 5 achieved between functional entities. Figure 1 illustrates the NRM including general HR-Network,
 6 Standalone network, HR-MS forwarding and HR-MS to HR-MS direct communication consisting of the
 7 following functional entities.

8

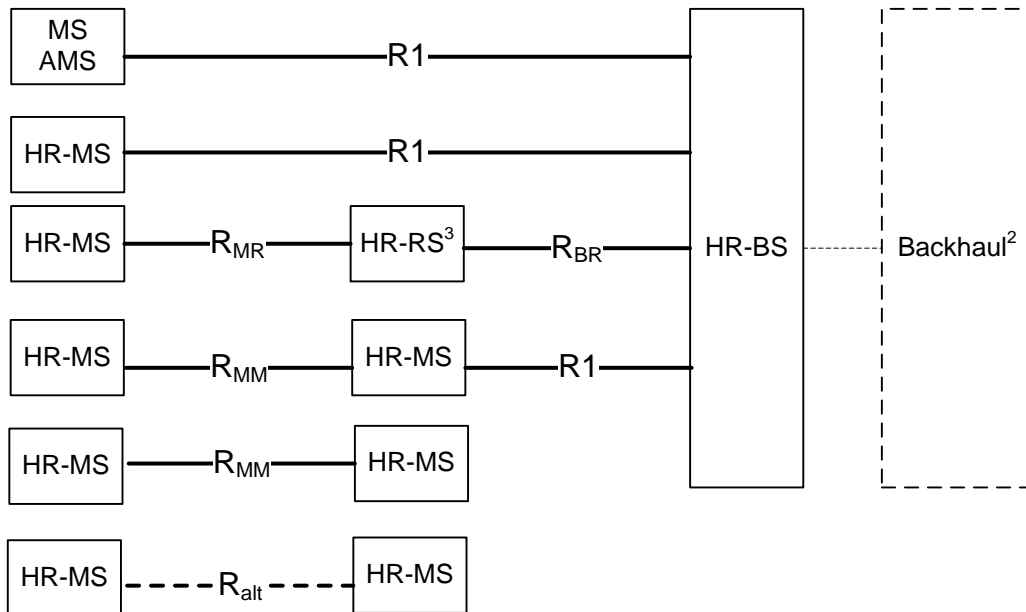

9

Figure 1 IEEE 802.16n Network Reference Model

Reference Points designated R1 consist of PHY and MAC protocols and procedures between a mobile station and a base station as specified in IEEE 802.16-2009, IEEE 802.16m and IEEE 802.16n

The Reference Point designated R_{MR} consists of PHY and MAC protocols and procedures between a mobile station and a relay station as specified in IEEE 802.16-2009, IEEE 802.16m and IEEE 802.16n.

The Reference Point designated R_{BR} consists of PHY and MAC protocols and procedures between a base station and a relay station as specified in IEEE 802.16j-2009, IEEE 802.16m and IEEE 802.16n.

The Reference Points designated R_{MM} consists of PHY and MAC protocols and procedures between mobile stations as specified in IEEE 802.16n.

The Reference Points designated R_{alt} consists of PHY and MAC protocols and procedures between mobile stations that are alternate connections specified in non-IEEE 802.16 standards. 16n will not specify non-802.16 interfaces. Instead, 16n will be aware of non-802.16 interfaces and provide functions to utilize them in achieving high reliability.

² When the connection between HR-BS and backhaul is unavailable, the HR-BS may maintain the connectivity between subordinated HR-MSs as a standalone network.

8.2 Interface Connection Chart

Table 1 shows the IEEE 802.16n interfaces that are supported and those that are not required to be supported in the IEEE 802.16n. The interfaces between HR-stations (i.e., HR-BSs, HR-RSs, HR-MSs) indicate that an IEEE 802.16n protocol is to be used for supporting high reliability. The interfaces between two entities where one of them is HR-station and the other is non HR-stations (i.e., ABS, ARS, AMS, BS, MR-BS, RS, and MS) indicates that either IEEE 802.16m or IEEE 802.16-2009/802.16j protocol is to be used for backward compatibility. The interface involving between non HR-stations indicates the specific either IEEE 802.16m or IEEE 802.16-2009/802.16j protocol is used and is out of scope of IEEE 802.16n.

The usage of the interfaces described in Table AA is constrained as follows:

- An HR-MS may connect to an HR-BS either directly, via an HR-RS, or via a forwarding HR-MS. At least two hops between an HR-BS and an HR-MS may be supported when the HR-MS is connected to an HR-BS via the HR-RS.
- An AMS may connect to an HR-BS either directly or via an HR-RS. Furthermore, an AMS may connect to an HR-BS via one ARS.
- An MS may connect to an HR-BS either directly or via an HR-RS. Furthermore, an MS may connect to an HR-BS via one or more RSs in multi-hop configuration.

Table 1 – Interconnection between the entities and the protocol used.

Notes to Table 1:

- 1) This table only refers to air interfaces between specific network entities. If a device is capable of role change, this table shows the link after the role changes. "n/a" means the interface between two entities is not applicable to IEEE802.16 air interface.
- 2) Yellow highlighted interfaces are in scope of 16n protocol, blue highlighted interfaces are backward compatible with either 16m or 16-2009/16j, and the rest of the interfaces are out of scope of 16n.

HR-BS	HR-RS	HR-MS	ABS	ARS	AMS	BS	MR-BS	RS	MS	
n/a	16n	16n	n/a	16m	16m	n/a	n/a	16j	16-2009	HR-BS ⁴
16n	16n	16n	16m	n/a	16m	n/a	16j	16j	16-2009	HR-RS ⁵
16n	16n	16n/alt	16m	16m	n/a	16-2009	16-2009	16-2009	n/a	HR-MS
n/a	16m	16m	n/a	16m	16m	n/a	n/a	16j	16-2009	ABS
16m	n/a	16m	16m	n/a	16m	n/a	n/a	n/a	16-2009	ARS
16m	16m	n/a	16m	16m	n/a	16-2009	16-2009	16-2009	n/a	AMS
n/a	n/a	16-2009	n/a	n/a	16-2009	n/a	n/a	n/a	16-2009	BS
n/a	16j	16-2009	n/a	n/a	16-2009	n/a	n/a	16j	16-2009	MR-BS
16j	16j	16-2009	16j	n/a	16-2009	n/a	16j	16j	16-2009	RS
16-2009	16-2009	n/a	16-2009	16-2009	n/a	16-2009	16-2009	16-2009	n/a	MS

³ Represents the case of multiple HR-RS's in multi-hop configuration

⁴ Includes HR-MS acting as an HR-BS

⁵ Includes HR-MS/HR-BS acting as an HR-RS

8.3 Protocol structure

Figure 2 shows the IEEE 802.16n Protocol Structure. As shown the figure, the IEEE 802.16n MAC is divided into two sublayers:

- Convergence Sublayer (CS)
- Common Part Sublayer (CPS)

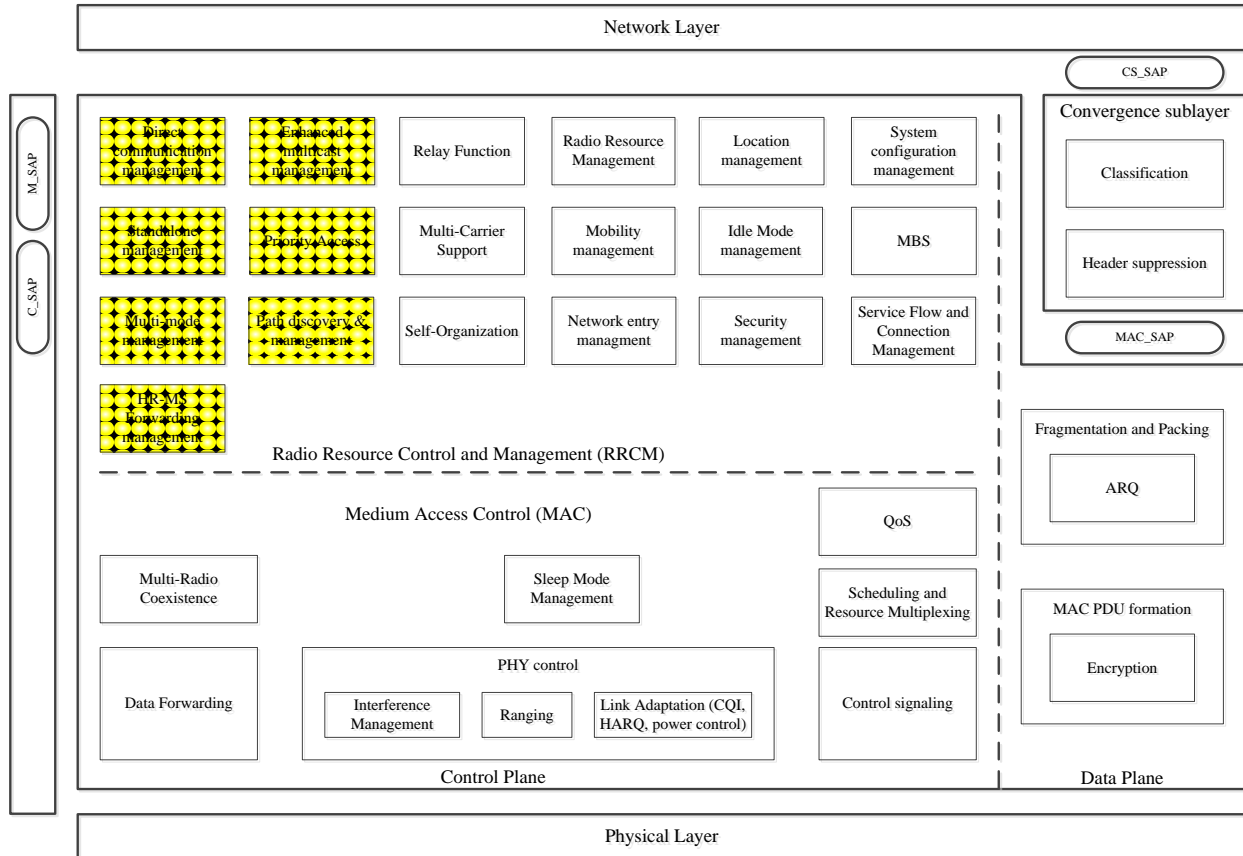

Figure 2: IEEE 802.16n Protocol Structure

The MAC Common Part Sublayer is further classified into Radio Resource Control and Management (RRCM) functions and medium access control (MAC) functions. The RRCM functions fully reside on the control plane. The functions reside on the control and data planes. The RRCM functions include several functional blocks that are related to radio resource functions such as:

- **Radio Resource Management:** Indicates a block which adjusts radio network parameters based on the traffic load, and also includes functions of load control (load balancing), admission, and interference control.
- **Mobility Management:** Indicates a block which supports functions related to Intra-RAT/Inter-RAT handover.
- **Network-entry Management:** Indicates a block which is in charge of initialization and access procedures. The Network-entry Management block may generate management messages which are needed during access-procedures, i.e., ranging, basic capability negotiation, registration, and

so on.

- Location Management: Indicates a block which is in charge of supporting location based service (LBS). The Location Management block may generate messages including the LBS information.
- Idle Mode Management: Indicates a block which manages location update operation during idle mode. The Idle Mode Management block controls idle mode operation, and generates the paging advertisement message based on paging message from paging controller in the core network side.
- System Configuration Management: Indicates a block which manages system configuration parameters, and transmits system configuration information to the HR-MS/HR-RS.
- MBS: Indicates a block which controls management messages and data associated with broadcasting and/or multicasting service.
- Service Flow and Connection Management: Indicates a block which allocates connection identifier during access/handover service flow creation procedures.
- Self Organization: Indicates a block which performs functions to support self-configuration and self-optimization mechanisms.
- Multi-Carrier: Indicates a block which enables a common MAC entity to control a PHY spanning over multiple frequency channels. The channels may be of different bandwidths (e.g. 5, 10 and 20 MHz) on contiguous or non-contiguous frequency bands. The channels may be of the same or different duplexing modes, e.g. FDD, TDD, or a mix of bidirectional and broadcast only carriers. For contiguous frequency channels, the overlapped guard sub-carriers are aligned in frequency domain in order to be used for data transmission.
- Security Management: Indicates a block which is in charge of authentication/authorization and key management for secure communication. Traffic encryption/decryption and authentication are performed using a managed encryption key. The Security Management block also supports security operation meeting the requirements described in Section 6.1.4.
- Relay Function: Indicates a block which includes functions to support relay mechanisms as described in section 6.1.1, 6.1.2, and 6.1.3.
- Direct Communication Management: Indicates a block which supports HR-MS to HR-MS direct communication meeting the requirements described in Section 6.1.3.1.
- HR-MS Forwarding Management: Indicates a block which supports HR-MS Forwarding meeting the requirements described in Section 6.1.3.2.
- Standalone Management: Indicates a block which supports standalone operation of immunizing the loss of HR-BS' backbone connectivity meeting the requirements described in Section 6.1.2.1.
- Multi-Mode Management: Indicates a block which supports multi-mode operation meeting the requirements described in Section 6.1.1.
- Enhanced Multicast: Indicates a block which controls management messages and data associated with multicast communication meeting the requirements described in Section 6.2.1.
- Path Discovery and Management: Indicates a block which controls and operates functionalities, including path discovery and path management meeting the requirements described in Section 6.1.3.3 and 6.1.3.4, respectively.
- Priority Access Management: Indicates a block which manages a priority access and connection meeting the requirements described in Section 6.2.3.

The control plane part of the Medium Access Control (MAC) functional group includes functional blocks which are related to the physical layer and link controls such as:

- PHY Control: Indicates a block which handles PHY signaling such as ranging, measurement/feedback (CQI), and HARQ ACK/NACK. Based on CQI and HARQ ACK/NACK, the PHY Control block estimates channel quality as seen by the HR-MS, and performs link

adaptation via adjusting modulation and coding scheme (MCS), and/or power level. In the ranging procedure, PHY Control block does UL synchronization with power adjustment, frequency offset and timing offset estimation.

- Control Signaling: Indicates a block which generates resource allocation messages.
- Sleep Mode Management: Indicates a block which handles sleep mode operation. The Sleep Mode Management block may also generate MAC signaling relate to sleep operation, and may communicate with Scheduling and Resource Multiplexing block in order to operate properly according to sleep period.
- QoS: Indicates a block which handles QoS management based on QoS parameters input from Service Flow and Connection Management block for each connection.
- Scheduling and Resource Multiplexing: Indicates a block which schedules and multiplexes packets based on properties of connections. In order to reflect properties of connections, the Scheduling and Resource Multiplexing block receives QoS information from QoS block for each connection.
- Multi-Radio Coexistence: Indicates a block which performs functions to support concurrent operations of IEEE 802.16m and non-IEEE 802.16m radios collocated on the same mobile station.
- Data Forwarding: Indicates a block which performs forwarding functions.
- Interference Management: Indicates a block which performs functions to manage the inter-cell/sector interference. The operations may include:
 - MAC layer operation
 - Interference measurement/assessment report sent via MAC signaling
 - Interference mitigation by scheduling and flexible frequency reuse
 - PHY layer operation
 - Transmit power control
 - Interference randomization
 - Interference cancellation
 - Interference measurement
 - Tx beamforming/precoding
- Inter-BS Coordination: Indicates a block which performs functions to coordinate the actions of multiple HR-BSs by exchanging information, e.g., interference management. The functions include procedures to exchange information for e.g., interference management between the HR-BSs by backbone signaling and by HR-MS MAC messaging. The information may include interference characteristics, e.g. interference measurement results, etc.

The data plane includes the following MAC functions:

- Fragmentation/Packing: Indicates a block which performs fragmenting or packing MSDUs based on scheduling results from Scheduling and Resource Multiplexing block.
- ARQ: Indicates a block which handles MAC ARQ function. For ARQ-enabled connections, a logical ARQ block is generated from fragmented or packed MSDUs of the same flow. The ARQ logical blocks are sequentially numbered. The ARQ block may also generate ARQ management messages such as feedback message (ACK/NACK information).
- MAC PDU formation: Indicates a block which constructs MAC control data unit (PDU) so that HR stations can transmit user traffic or management messages into PHY channel. MAC PDU formation block adds MAC header and may add sub-headers. Based on input from the security management block, the encryption block can encrypt user traffic or management message by a managed encryption key.

