

Project	IEEE 802.16 Broadband Wireless Access Working Group < http://ieee802.org/16 >	
Title	Enhancements to UCP LBT	
Date Submitted	2007-09-11	
Source(s)	Paul Piggin NextWave Broadband Ken Stanwood NextWave Wireless Yair Bourlas NextWave Broadband Kathy Sohrabi NextWave Broadband	Voice: + 44 1249 800167 E-mail: ppiggin@nextwave.com Voice: +1 858 480 3327 E-mail: kstanwood@cygnuscom.com Voice: +1 858 480 3279 E-mail: ybourlas@nextwave.com Voice: +1 858 480 0549 E-mail: ksohrabi@nextwave.com
Re:	IEEE 80216-07/019 Task Group Review of P802.16h/D2c	
Abstract	Enhancement to UCP LBT based on simulation results and analysis	
Purpose	To address a handful of improvements to the LBT portion of the section 6.4 UCP.	
Notice	<i>This document does not represent the agreed views of the IEEE 802.16 Working Group or any of its subgroups. It represents only the views of the participants listed in the "Source(s)" field above. It is offered as a basis for discussion. It is not binding on the contributor(s), who reserve(s) the right to add, amend or withdraw material contained herein.</i>	
Release	The contributor grants a free, irrevocable license to the IEEE to incorporate material contained in this contribution, and any modifications thereof, in the creation of an IEEE Standards publication; to copyright in the IEEE's name any IEEE Standards publication even though it may include portions of this contribution; and at the IEEE's sole discretion to permit others to reproduce in whole or in part the resulting IEEE Standards publication. The contributor also acknowledges and accepts that this contribution may be made public by IEEE 802.16.	
Patent Policy and Procedures	The contributor is familiar with the IEEE-SA Patent Policy and Procedures: < http://standards.ieee.org/guides/bylaws/sect6-7.html#6 > and < http://standards.ieee.org/guides/opman/sect6.html#6.3 >. Further information is located at < http://standards.ieee.org/board/pat/pat-material.html > and < http://standards.ieee.org/board/pat >.	

Enhancements to UCP LBT

Paul Piggin, Ken Stanwood, Yair Bourlas, Kathy Sohrabi
NextWave Wireless

1. Overview

The purpose of the UCP in section 6.4 of [1] is to allow synchronous 802.16 systems to coexist on a co-channel basis with asynchronous systems. The primary asynchronous system of interest is 802.11. Additionally, the features are structured to meet the requirements of the 3.65 GHz band in the US. As we continue to refine the simulations and analysis [5], enhancements come to light that can improve coexistence.

1.1 Aggravated Hidden Node Problem in 3.65 GHz Band

The analysis in [3] showed that in bands such as 3.65 GHz in the US, there is an aggravated hidden node problem due to the distinctly lower transmit power allowed for mobile devices compared to fixed, registered devices. The mobiles are more often geographically disadvantaged due to this transmit power disparity. Fixed, registered client devices can also be geographically disadvantaged (the classical hidden node problem), although not as often. To remedy this we propose to add a Frame Reservation Signal (FRS) that acts like the Clear to Send (CTS) message in an 802.11 system which helps alleviate the hidden node problem in 802.11. (See [2].) This signal would be transmitted by the BTS at the end of the DL subframe to reserve the subsequent UL subframe (or used portion, thereof) for the subscriber stations. The form of the FRS is band dependent and should be structured so as to be as receivable as possible by other technologies that may be co-channel. For instance, in bands where 802.11 would be a typical co-channel asynchronous system, the 802.11 CTS transmitted using the appropriate 802.11 burst structure would suffice.

1.2 802.11 AIFS Longer than UL-DL Gap for 5 and 10 MHz Channels

During previous analysis [4] it was shown that in most cases for 10 MHz channels and all cases for 5 MHz channels, the minimum gap between the end of the UL subframe and the start of the next DL subframe is too short for an 802.11 system to detect that the medium is free and claim the channel. This would result in a situation where 802.16h systems would only provide 802.11 systems with an opportunity to transmit in frames where they were intentionally quiet such as those forming an EQP. This would cause LBT to not perform its intended function. Internal analysis shows that while aEQP alone may work well when 802.11 traffic volume is high relative to 802.16h traffic volume, LBT with a properly sized gap is more effective at giving 802.11 transmission opportunities while not unnecessarily wasting bandwidth on overabundant quiet periods in the case when 802.16 traffic volume is similar or high relative to 802.11 traffic volume.

The following Figure shows how the 802.11 AIFS is the sum of SIFS and two times the SlotTime Duration. This is the minimum wait between the medium being free and an 802.11 system transmitting unless the 802.11 system is in the Contention Window phase in which case, the minimum wait is SlotTime.

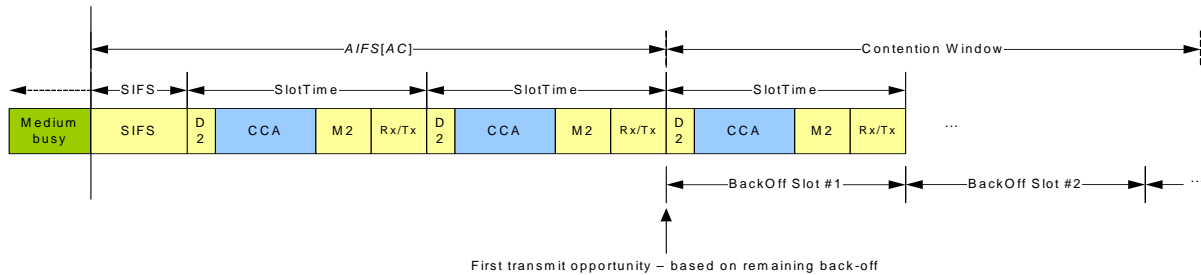

The following table gives the values for 5, 10, and 20 MHz channels. Units are microseconds.

Table 1: Minimum Channel Access Time

	20MHz	10 MHz	5 MHz
D2 (example duration)	1	1	1
CCA	4	8	16
M2	2	2	2
Rx/Tx	2	2	2
SlotTime	9	13	21
SIFS	16	32	64
AIFS	34	58	106

To remedy this we propose to require that the gap between the end of the UL subframe and the start of the next DL subframe be sufficiently large to accommodate an 802.11 system operating with the same channel width. The method to achieve this is scenario dependant. Depending on the channel bandwidth, planned cell size, and resultant round trip delay, it may be sufficient to merely reduce the duration of the gap between the DL subframe and the subsequent UL subframe, consequently lengthening the gap between the UL subframe and the subsequent DL subframe. In some cases, it may be necessary to refrain from using some number of symbols.

1.3 UL Map Relevance

In order to make the DL and subsequent UL subframe appear logically as a single 5 ms packet, [1] declares that a UL map frame relevance of the current frame must be used. Once the FRS is added, this requirement disappears. To remedy this we propose to remove the requirement that the UL Map frame relevance is the current frame and allow any valid UL Map frame relevance.

1.4 SS LBT

Before the FRS was introduced, even if a DL subframe and the subsequent UL subframe were viewed logically as a single 5 ms packet, in reality an 802.11 system could still claim the medium due to the duration of the gap between the DL subframe and the subsequent UL subframe. After the introduction of the FRS, the likelihood of this is very small. As such, there is no longer a necessity for the SS to perform LBT as long as the SS only transmits in frames where it heard the DL subframe. For UL Map relevance of the current frame, this is always the case. For UL Map relevance of the next frame, in frames where the BS does not transmit due to LBT the UL Map relevance is extended to the next frame in which the BS transmits a DL, same as the case for EQP shown in Figure h13 of [1]. So, the SS will never transmit in a frame unless the BS has already preformed an LBT and transmitted an FRS.

Therefore, we propose to eliminate the SS LBT requirement.

1.5 Reclaiming the Medium

Once the gap between the UL subframe and the subsequent DL subframe is of sufficient duration to allow 802.11 systems to access the medium, in cases of high traffic volume for both 802.11 and 802.16h systems, the synchronous nature of 802.16h systems disadvantage them relative to 802.11 systems. Generally, an 802.11 system will access the medium very soon after it has become free while an 802.16h system waits until the 5 ms frame boundary to reclaim the medium. We propose a mechanism, called Dynamic Medium Access (DMA), by which an 802.16h system can determine that it is not receiving its fair share of the channel occupancy relative to other co-channel systems.

This is composed of determining a time in advance of the 5 ms frame boundary at which the BS desires to transmit an FRS to reserve the downlink. In general, this FRS only need be sent when the BS has had difficulty reacquiring the channel after it was acquired by an asynchronous system. Additionally, how far in advance of the frame boundary the FRS may be sent must be strictly controlled and be based on the concept of fairness of occupancy of the channel.

The BS is assigned a utilization goal that is based on the number of co-channel systems. For instance, if an 802.16h system is sharing the channel with one 802.11 system, it's utilization goal would be 50%. If it is sharing the channel with another 802.16h system and an 802.11 system, its utilization ratio would be 33%. Determination of the number of co-channel systems may be accomplished via sensing or may be determined by administrative means (database of registered systems, etc.). The method is immaterial to the algorithm.

If the BS's current utilization of the channel (measured over time) is at or above its utilization goal, the BS does not exert extra effort to reclaim the channel because it is receiving fair occupancy. In this case the BS merely performs LBT sufficiently ahead of transmitting the downlink to sense the medium is free and start transmitting.

If the BS's current utilization of the channel is less than its utilization goal, the BS exerts extra effort to reclaim the medium by assessing the channel conditions increasingly earlier before the start of the 5 ms frame boundary (up to a maximum). When the BS detects the medium is available, it transmits an FRS to claim the downlink subframe. The algorithm has the following terms and equations:

FRST_n - Frame Reservation Start Time. This defines the time before the start of frame n at which the BS starts sensing whether the channel is free and prepares to send an FRS.

MAXFRST - the maximum value of *FRST*. Band dependent. For example, in the 3.65 GHz band 4 ms is a reasonable value since any 802.11y burst would be shorter and could fit before the start of the 802.16 frame.

MINFRST - the minimum value of *FRST*. Implementation dependant. This is the minimum value the FRST can take based on the ability of the BS to sense and claim the channel. It must be smaller than the gap between the end of one UL subframe and the start of the subsequent DL subframe.

UtilizationGoal - the "fair" channel occupancy for this system.

CurrentUtilization - the currently achieved channel occupancy for this system. To ensure that the 802.16 system does not attempt to claim the channel excessively when the 802.16 system has little or no demand, *CurrentUtilization* is only calculated over frames when the 802.16 system has data to transmit. It is calculated using a sliding window or exponential decay to represent a reasonable period in the immediate past.

UtilizationRatio - the metric indicating the level to which the *UtilizationGoal* has been achieved.

The *UtilizationRatio* is calculated according to the following formula, where K is an aggressiveness factor to be determined by simulation. (So far, simulation results [5] show very little difference between k = 1, 2, 4, etc.).

$$UtilizationRatio = \left(\frac{UtilizationGoal}{CurrentUtilization} \right)^K$$

FRST_n is calculated according to the following formula. It may be modified to be more aggressive when it is necessary to transmit to maintain synchronization.

$$FRST_n = \text{MIN}(\text{MAXFRST}, \text{MAX}(\text{UtilizationRatio} \times FRST_{n-1}, \text{MINFRST}))$$

The parameters are applied as shown in the following Figure.

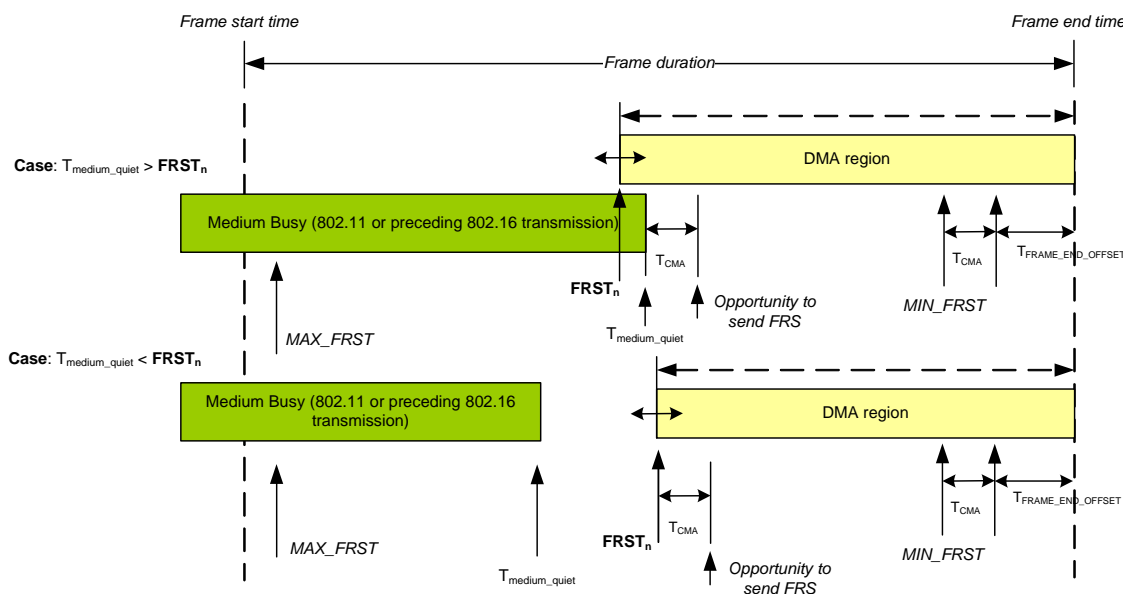

$MIN_FRST = T_{CMA} + T_{FRAME_END_OFFSET}$
 $T_{FRAME_END_OFFSET} = 50\mu\text{s}$ (minimum time to Rx/Tx and send FRS)
 $T_{CCA} = 4/8/16\mu\text{s}$ (20MHz/10MHz/5MHz channels) – aligned with 802.11 values
 $MIN_FRST = 54/58/66\mu\text{s}$
 $MAX_FRST = 4000\mu\text{s}$
 802.16 parameters
 5ms 802.16 frame duration
 47 symbols per frame [DL=28, UL=19] symbol duration ~102 μs
 TTG = 5 μs

The Frame maker file is available for the editor.

2. Specific Editing Changes

This document provides changes to IEEE P802.16h/D2b [1].

Blue underlined text represents specific editing changes.

~~Red strikethrough~~ text is to be deleted.

Black text is already in the draft.

Bold italics text is editing instructions to the editor.

The following headers are just to get the section numbers correct since I don't know how to reset the numbers in Frame Maker.

3. Bogus H1

4. Bogus H1

5. Bogus H1

6. Bogus H1

6.1 Bogus H2

6.2 Bogus H2

6.3 Bogus H2

6.4 Bogus H2

6.4.1 Bogus H3

6.4.2 Bogus H3

6.4.2.1 Bogus H4

6.4.2.2 Bogus H4

6.4.2.3 Bogus H4

6.4.2.3.1 Bogus H5

6.4.2.3.2 Bogus H5

6.4.2.3.3 Bogus H5

6.4.2.3.4 Bogus H5

6.4.2.3.5 Bogus H5

6.4.2.3.6 Bogus H5

6.4.2.3.7 Listen-Before-Talk (LBT)

When attempting to coexist with certain asynchronous non-802.16 users of non-exclusively assigned or non-exclusively licensed bands, EQPs may not be sufficient. In these cases, a LBT protocol must be used and EQP are optional. In such bands, ~~the BS shall operate with a UL-MAP relevance of the current frame. This allows~~ the DL and UL subframes to be logically viewed as a single "packet" of constant duration equal to the frame duration. Steps are taken, as described below to use this concept to minimize interference with co-channel asynchronous systems. The BS shall periodically allocate opportunities for an SS to measure and report on the current state of the channel, and provide input to the LBT protocol. An Extended Channel Measurement IE (see for example sub clause 8.4.5.3.5) may be used, to provide such an opportunity.

In ~~a similar way in~~ the gap between the UL and DL subframes, ~~as close to time to transmit the DL as possible,~~ the BS shall make measurements on the current state of the channel. The general case with three co-channel 802.16 systems is shown in *Figure h 1*.

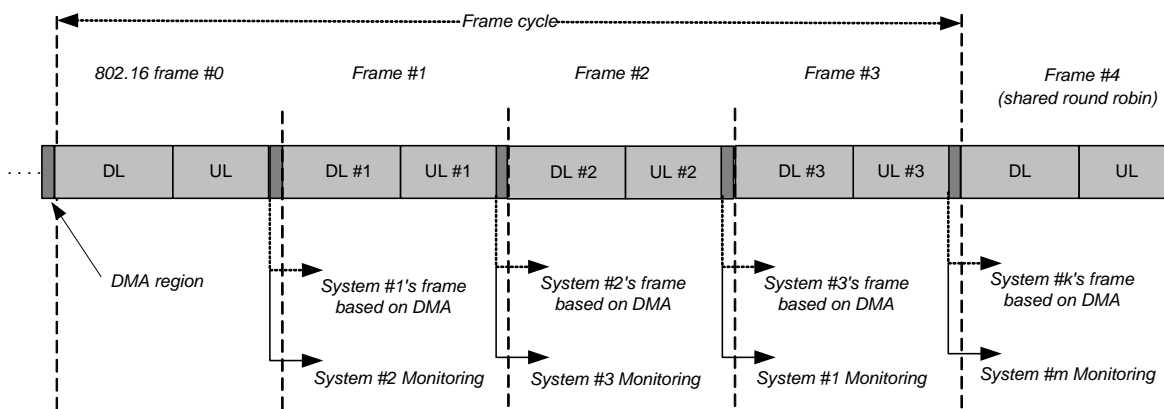

Notes:
 This example presents 3 802.16 systems sharing.
 Each system updates its own DMA algorithm before monitoring of a frame begins

Figure h1—Basic LBT Opportunities

The gap between the end of the UL and the start of the DL in which Clear Medium Assessment (CMA) is performed must be of sufficient length to allow an asynchronous system to claim the channel if necessary. For instance if the

asynchronous system is an 802.11 system, the gap must be at least the duration of the 802.11 AIFS in the band of interest. CMA is similar to the Clear Channel Assessment (CCA) of 802.11 based systems. In this way CMA is a measurement based report that provides an indication (to a certain probability and to a certain threshold level) of whether or not the medium is quiet and therefore available for use.

Given that the LBT protocol detects energy above the defined threshold then no transmission will take place in the succeeding subframe. The use of the LBT protocol shall recognize appropriate use of the Lost DL/UL MAP Interval parameter in table 342. Transmission may recommence per the dynamic medium access (DMA) protocol when energy levels drop below the threshold level. Due to the fact that there may would be no time to signal an energy detection event then a BS or SS shall reliably handle the absence of a subframe where it was previously scheduled by the DL or UL-MAP. Similar to the case with EQP, when a DL is not transmitted due to LBT, the UL MAP is for the next frame in which there is a DL. An example of this arrangement is given in *Figure h 2* for systems with UL MAP relevance of N and in *Figure h 3* for systems with UL MAP relevance of N+1. The frame in which the system refrained from transmitting shall be used to sense other non-802.16 systems. The minimum duration is 4 us. ~~Specific implementation of this protocol is not specified and is left for vendor differentiation.~~ Use of LBT shall not eliminate any requirements for other measurement and reporting that may be required for operation in a particular mode or band. ~~Use of listen-before-talk shall not eliminate any requirement for use of EQPs. However, r~~Refraining from transmitting during a frame due to energy detection during the LBT “listen” period shall count towards fulfilling the quite percentage of the aEQP duty cycle.

[Replace the following Figure.]

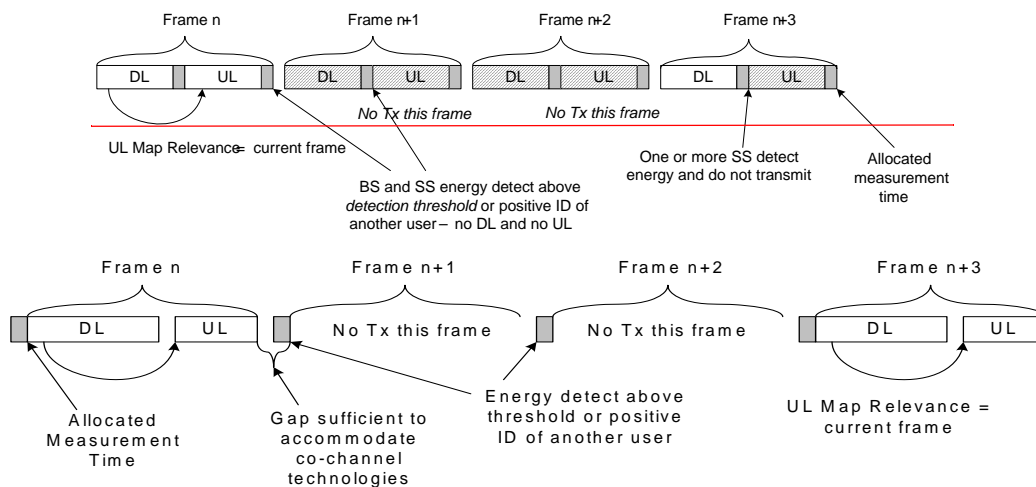

Figure h2—LBT - UL MAP Relevance N

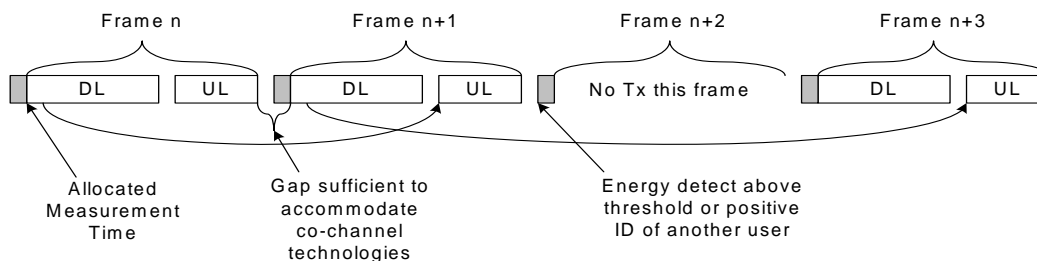

Figure h3—LBT - UL MAP Relevance N+1

In cases of high traffic volume for both co-channel asynchronous and 802.16h systems, the synchronous nature of 802.16h systems disadvantage them relative to asynchronous systems. Generally, an asynchronous system will access the medium very soon after it has become free while an 802.16h system waits until the frame boundary (typically 5 ms) to reclaim the medium. The Dynamic Medium Access (DMA) protocol enables an 802.16h system to determine that it is not receiving its fair share of the channel occupancy relative to other co-channel systems and regain the medium.

The DMA protocol consists of determining a time in advance of the start of the DL subframe at which the BS desires to transmit a Frame Reservation Signal (FRS) to reserve the downlink. In general, this FRS only need be sent when the BS has had difficulty reacquiring the channel after it was acquired by an asynchronous system. Additionally, how far in advance of the frame boundary the FRS may be sent must be strictly controlled and be based on the concept of fairness of occupancy of the channel.

To ensure fairness, the BS is assigned a utilization goal that is based on the number of co-channel systems. For instance, if an 802.16h system is sharing the channel with one other system, its utilization goal would be 50%. If it is sharing the channel with another 802.16h system and an 802.11 system, its utilization ratio would be 33%. Determination of the number of co-channel systems may be accomplished via sensing or may be determined by administrative means (database of registered systems, etc.). The method is immaterial to the protocol.

If the BS's current utilization of the channel (measured over time) is at or above its utilization goal, the BS does not exert extra effort to reclaim the channel because it is receiving fair occupancy. In this case the BS merely performs LBT sufficiently ahead of transmitting the downlink to sense the medium is free and start transmitting.

If the BS's current utilization of the channel is less than its utilization goal, the BS exerts extra effort to reclaim the medium by assessing the channel conditions increasingly earlier before the start of the DL subframe up to a point in time, *MINFRST*, described below. When the BS detects the medium is available, it transmits an FRS to claim the downlink subframe. The protocol has the following terms and equations:

FRST_n - Frame Reservation Start Time. This defines the time before the start of frame n at which the BS starts sensing whether the channel is free and prepares to send an FRS.

MAXFRST - the maximum value of *FRST*. Band dependent. For example, in the 3.65 GHz band in the US 4 ms is a reasonable value since any 802.11 burst in this band would be shorter and could fit before the start of the 802.16 frame.

MINFRST - the minimum value of *FRST*. Implementation dependant. This is the minimum value the *FRST* can take based on the ability of the BS to sense and claim the channel. It must be smaller than the gap between the end of one UL subframe and the start of the subsequent DL subframe.

UtilizationGoal - the "fair" channel occupancy for this system, based on number of co-channel systems as described above.

CurrentUtilization - the currently achieved channel occupancy for this system. To ensure that the 802.16 system does not attempt to claim the channel excessively when the 802.16 system has little or no demand, *CurrentUtilization* is only calculated over frames when the 802.16 system has data to transmit. It is calculated using a sliding window or exponential decay to represent a reasonable period in the immediate past.

UtilizationRatio - the metric indicating the level to which the *UtilizationGoal* has been achieved.

The *UtilizationRatio* is calculated according to the following formula, where K is an aggressiveness factor to be determined by simulation. (So far, simulation results show very little difference between $k = 1, 2, 4$, etc.).

$$UtilizationRatio = \left(\frac{UtilizationGoal}{CurrentUtilization} \right)^K$$

$FRST_n$ is calculated according to the following formula. It may be modified to be more aggressive when necessary to maintain synchronization.

$$FRST_n = MIN(MAXFRST, MAX(UtilizationRatio \times FRST_{n-1}, MINFRST))$$

The parameters are applied as shown in Figure h 4.

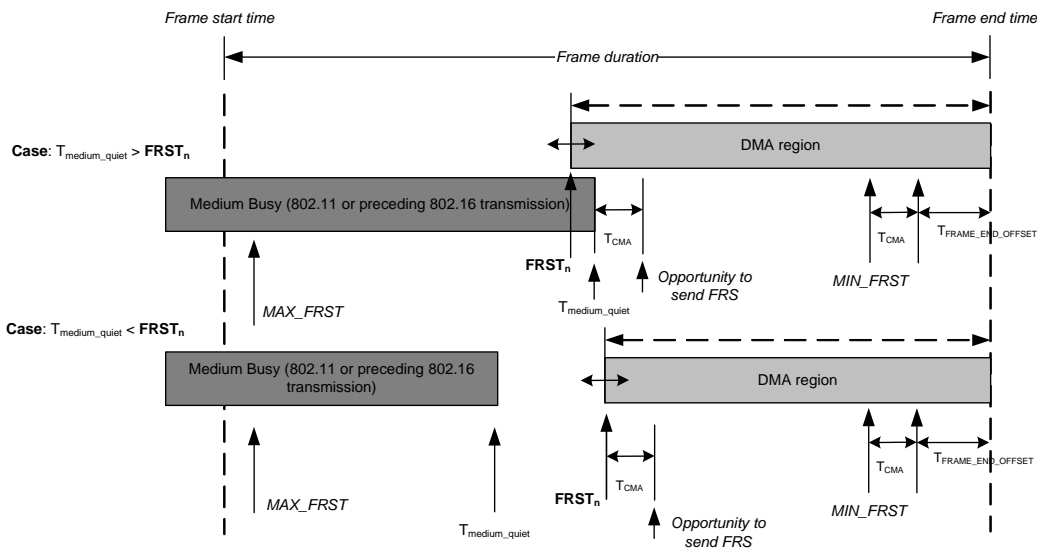

$MIN_FRST = T_{CMA} + T_{FRAME_END_OFFSET}$
 $T_{FRAME_END_OFFSET} = 50\mu s$ (minimum time to Rx/Tx and send FRS)
 $T_{CCA} = 4/8/16\mu s$ (20MHz/10MHz/5MHz channels) – aligned with 802.11 values
 $MIN_FRST = 54/58/66\mu s$
 $MAX_FRST = 4000\mu s$
 802.16 parameters
 5ms 802.16 frame duration
 47 symbols per frame [DL=28, UL=19] symbol duration ~102 μs
 TTG = 5 μs

Figure h4—Reclaiming the Medium

The BS SDL for the DMA protocol for reclaiming the medium is shown in Figure h 5.

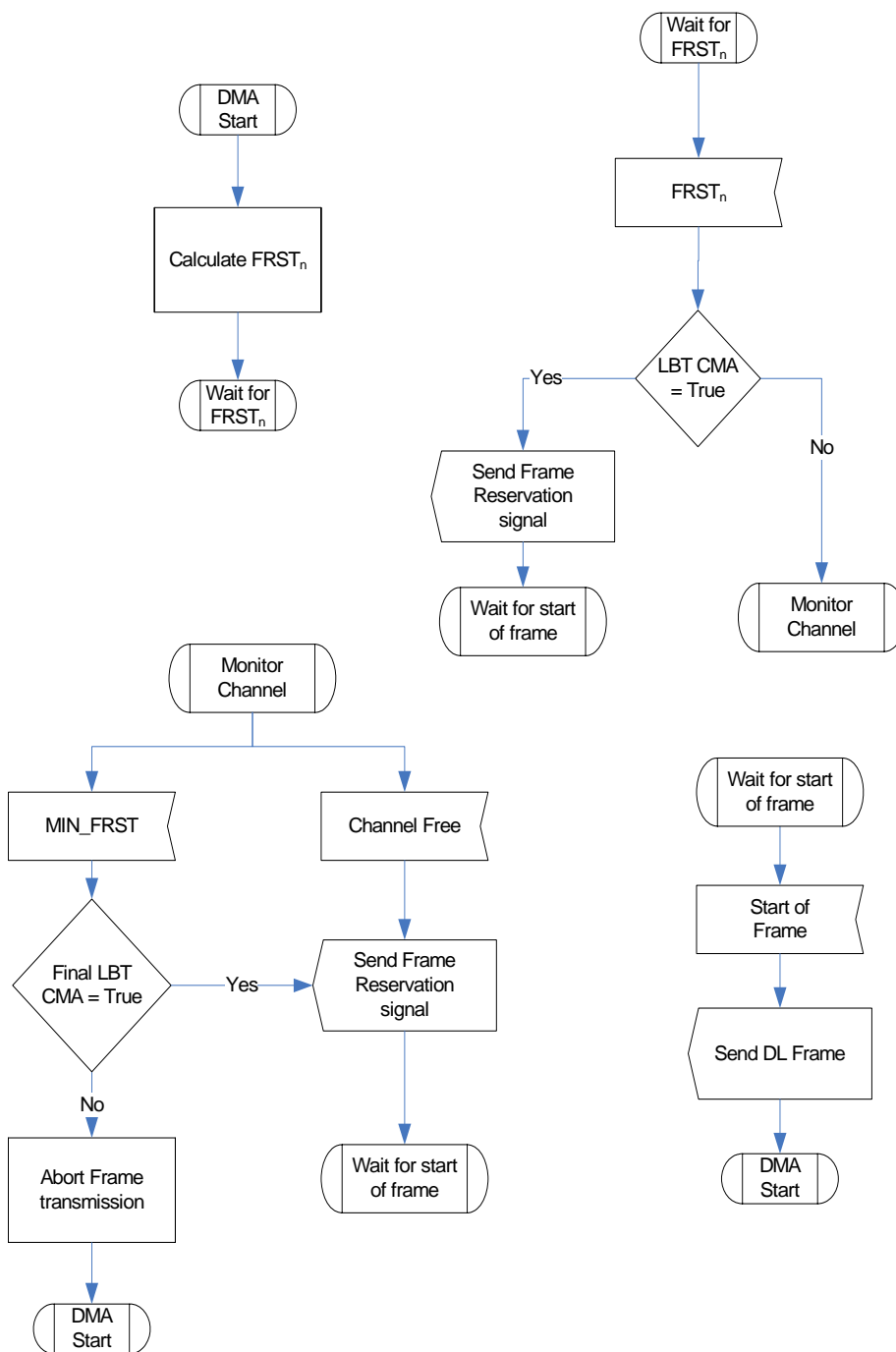

Figure h5—BS Dynamic Medium Access Protocol

When using any carrier sense protocol, such as LBT, in a wireless environment the hidden node problem cannot be 100% avoided. It can only be mitigated. Additionally, in bands such as 3.65 GHz in the US, there is an aggravated hidden node problem due to the distinctly lower transmit power allowed for mobile devices compared to fixed, registered devices. The mobiles are more often geographically disadvantaged due to this transmit power disparity. Fixed, registered client devices can also be geographically disadvantaged (the classical hidden node problem), although not as often. To remedy this the BS transmits a Frame Reservation Signal (FRS) at the end of the DL subframe to reserve

the subsequent UL subframe (or used portion, thereof) for the subscriber stations. The form of the FRS is band dependent and should be structured to be receivable by other technologies that may be co-channel. For instance, in bands where 802.11 would be a typical co-channel asynchronous system, the 802.11 CTS transmitted using the appropriate 802.11 burst structure would suffice. The reservation of the UL subframe by the BTS precludes the need for the SS to also perform LBT. The use of the FRS to protect the UL is shown in Figure h 6.

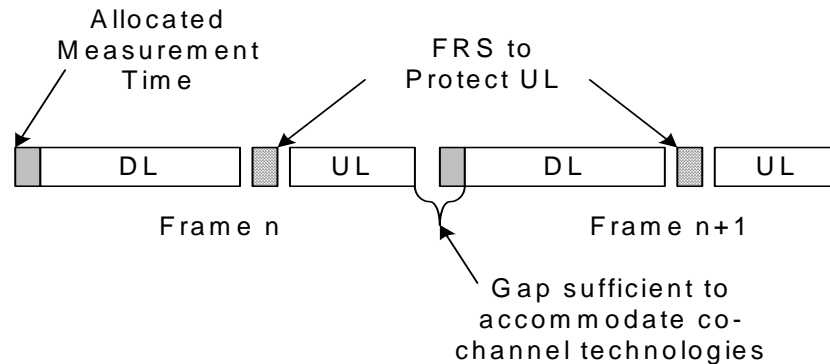

Figure h6—UL FRS

7. References

- [1] IEEE P802.16h/D2c: *Air Interface for Fixed Broadband Wireless Access Systems Improved Coexistence Mechanisms for Licensed Exempt Operation*, Working Group Draft, 31 July 2007.
- [2] IEEE Std 802.11-2007, “*IEEE Standard for Information technology - Telecommunications and information exchange between systems - Local and metropolitan area networks - Specific Requirements, Part 11: Wireless LAN Medium Access Control (MAC) and Physical Layer (PHY) Specifications*”, 12 June 2007.
- [3] IEEE 802.19-07/0010r1, “*Clear Channel Assessment Energy Detection (CCA-ED) in 802.11y*”, Steve Shellhammer, 29 May 2007.
- [4] IEEE S802.16-07/050, “*Simulating coexistence between 802.11y and 802.16h systems in the 3.65 GHz band - An amendment for 802.11e*”, Paul Pigginn, 3 May 2007.
- [5] IEEE C802.16h-07_082, “*Enhancements to UCP LBT: Supporting Simulation results*”, Paul Pigginn, 7 Sept. 2007.