

Project	IEEE 802.16 Broadband Wireless Access Working Group < http://ieee802.org/16 >	
Title	Optimizing Channel Throughput using Target Packet Error Rates	
Date Submitted	2005-11-17	
Source(s)	Jose Puthenkulam	Voice: (503) 264 6121
	Intel Corporation	Email: jose.p.puthenkulam@intel.com
	Muthaiah Venkatachalam	Voice: (503) 712 5583
	Intel Corporation	Email: muthaiah.venkatachalam@intel.com
	Hujun Yin	Voice : (408) 765 1877
	Intel Corporation	Email : hujun.yin@intel.com
	Kenneth Stanwood	Voice : (740)448-1984
	Cygnus Communications	Email : kstanwood@cygnuscom.com
Re:	Call for comments	
Abstract		
Purpose	This document proposes improvements for increased channel throughput using Target Packet Error Rates	
Notice	This document has been prepared to assist IEEE 802.16. It is offered as a basis for discussion and is not binding on the contributing individual(s) or organization(s). The material in this document is subject to change in form and content after further study. The contributor(s) reserve (s) the right to add, amend or withdraw material contained herein.	
Release	The contributor grants a free, irrevocable license to the IEEE to incorporate material contained in this contribution, and any modifications thereof, in the creation of an IEEE Standards publication; to copyright in the IEEE's name any IEEE Standards publication even though it may include portions of this contribution; and at the IEEE's sole discretion to permit others to reproduce in whole or in part the resulting IEEE Standards publication. The contributor also acknowledges and accepts that this contribution may be made public by IEEE 802.16.	
Patent Policy and Procedures	The contributor is familiar with the IEEE 802.16 Patent Policy and Procedures < http://ieee802.org/16/ipr/patents/policy.html >, including the statement "IEEE standards may include the known use of patent(s), including patent applications, provided the IEEE receives assurance from the patent holder or applicant with respect to patents essential for compliance with both mandatory and optional portions of the standard." Early disclosure to the Working Group of patent information that might be relevant to the standard is essential to reduce the possibility for delays in the development process and increase the likelihood that the draft publication will be approved for publication. Please notify the Chair < mailto:chair@wirelessman.org > as early as possible, in written or electronic form, if patented technology (or technology under patent application) might be incorporated into a draft standard being developed within the IEEE 802.16 Working Group. The Chair will disclose this notification via the IEEE 802.16 web site < http://ieee802.org/16/ipr/patents/notices >.	

Optimizing Channel Throughput using Target Packet Error Rates

Jose Puthenkulam, Muthaiah Venkatachalam, Hujun Yin

Intel Corporation,

Kenneth Stanwood, Cygnus Communications.

1 Introduction

In the IEEE 802.16 standard today Service Flows are used to manage logical transport of packets of the Air interface. Different service flows will inherently be able to tolerate different PERs . For example, Voice packets cannot tolerate more than 1% PER for reasonable quality. Data packets however can operate on a 10%-40% PER with ARQ or HARQ schemes overall improving the reliability of the transport and bringing down the “residual PER” seen by the applications down to as low as 1%. The advantage of operating at a higher target PER and then later fixing the errors via ARQ/HARQ is that the overall capacity and spectral efficiency of the system improves upto a certain PER target (since higher operational PERs, means more aggressive MCS selections). Figures 1a) and 1b) show simulation results, whereby we can see that for a CID running TCP on BE QoS and ARQ, up until over 15%, there is no loss in throughput, while the overall system capacity increases. Beyond this knee point, the throughput and the capacity drop. This essentially tell us that we can operate this TCP CID at 20% PER with minimal loss in TCP throughput, while increasing the system capacity by 60%.

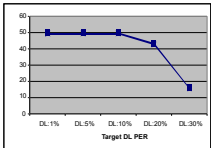

Figure 1a) Individual TCP throughput vs Target PER

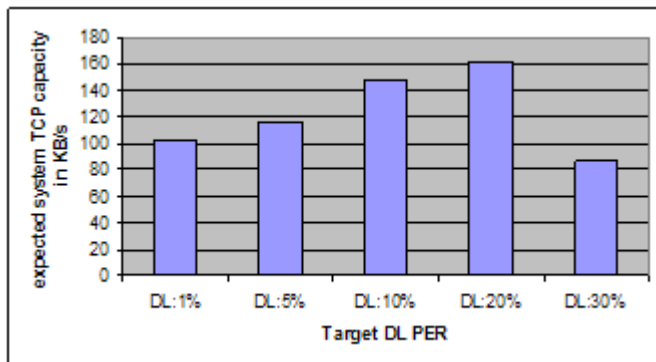

Figure 1b): Aggregate System Capacity vs Target PER

As 802.16 standard service flows have a target for their maximum traffic rate (bit rate) and also have service classes like Unsolicited Grant Service (UGS) (or known as constant bit rate service), Real Time Packet Service (RTPS) or Non-Real Time Packet Service (NRTPS) or Extended RTPS (ERTPS) that could support voice

activity detection or Best Effort Service (BES) for managing prioritization of traffic, it is possible to use a combination of priority queues and schemes like HARQ for improving the performance of the transport over the air interface. For this to be even more effective, this contribution proposes a management message enhancement using a target PER associated with every service flow as an added parameter provided by the application layer to ensure that ARQ or HARQ operation is better fine tuned give the desired traffic management results.

The current issues with 802.16:

There are currently 2 issues that need to be addressed in 802.16.

Issue A) 802.16 presently creates service flows without an assigned PER target. Hence the implicit assumption is that all the connections operate at the same PER target. This will lead to suboptimal system performance as we cannot realize the gains as described in Figure-1 in a mixed application scenario. Further more, operating all the service flows indiscriminately at a higher PER will lead to detrimental QoS for those flows that cannot employ ARQ or HARQ due to latency constraints – eg VoIP or real time streaming/broadcast

Issue B) Also, since PER is not specified as part of the service flow initiation, PER is also not considered as part of the UL grant allocation to the MS currently in 802.16. Consider a scenario, where a MS has 2 CIDs each with a different PER target. Given that all grants happen on the basic CID of the MS, the MS will not be able to differentiate between the grants for these two CIDs and thereby may end up transmitting data for a low PER CID on a grant with a high associated PER – thereby leading to unpredictable QoS and PER realizations.

Proposed solutions:

Issue A:

The solution is to add a PER target parameter to the Service flow creation/modification MAC layer constructs/messages. This will allow the MAC scheduler on the UL/DL to appropriately recognize what type of link adaptation scheme like ARQ or HARQ is best used for improving reliability.

The following Type Length Value (TLV) parameter called Target PER TLV is used with Dynamic Service Flow Add Request (DSA-REQ) and Response (DSA-RSP) messages. It is also used in the Dynamic Service Flow Change Request (DSC-REQ) and Response (DSC-RSP) messages when target PERs could be changed during lifetime of a service flow.

Target PER TLV

Type	Length	Value	Scope
PER-TLV	1	1-99 (indicating %)	DSA-REQ/RSP, DSC-REQ/RSP

Compatibility in use:

The expectation is that when the 802.16g compliant SS or BS use DSA-REQ/RSP or DSC-REQ/RSP messages services this additional Target PER TLV may be included for communicating target PER between the SS and BS. If a 802.16g non-compliant SS or BS uses these messages this optional Target PER TLV may not be included but operation will continue as normal but will not benefit from this enhancement.

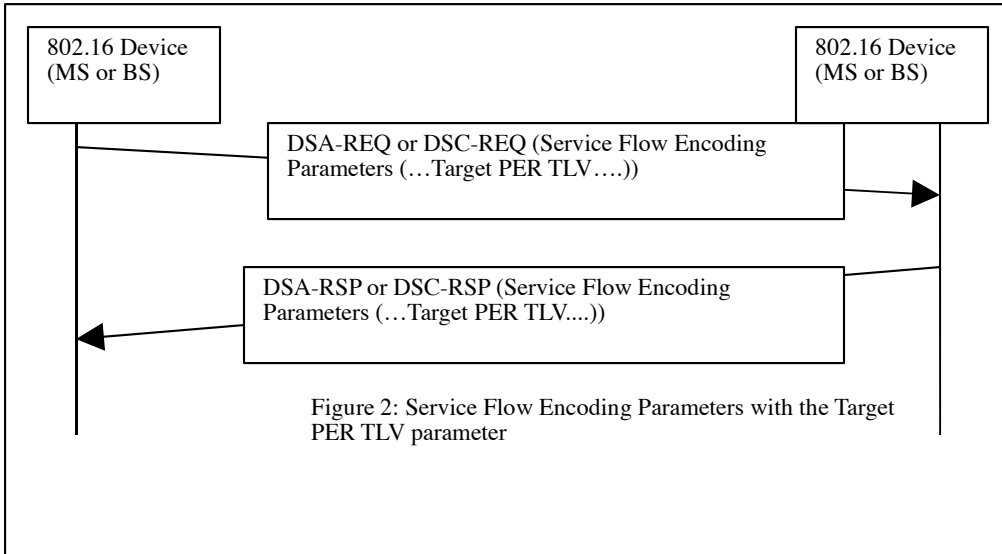

Issue B:

In uplink, the transmit power is adjusted according to the MCS level. The power offset with regard to MCS level is shown in Table 334 (8.4.10.3). This offset is for a specific target BER. For uplink to achieve different target BER, the offsets should be defined for each target BER. The table shall also be reconfigurable using dedicated UCD message TLV.

2 Proposed Text Changes

[Insert the following text into sections identified]

Issue A:

Section 11.13: Table 383 – add the following as part of the service flow encodings.

Type	Parameter
47	PER

New Section 11.13.47 with the following text and table:

This TLV indicates the target packet error rate (PER) for the service flow as defined below. This PER could either be the PER as seen by the application (post ARQ and/or HARQ processing) or as seen on the airlink (before the application of ARQ and/or HARQ). The particular use of this TLV is left open to implementations and vendor differentiations. Some usage scenarios, however could be: to determine whether to enable HARQ or not; to determine whether to enable ARQ or not; to choose a more aggressive or more robust burst profile etc. Support for setting the PER using this TLV is optional for both BS and MS.

Type	Length	Value	Scope
------	--------	-------	-------

[145/146].47	1	<p>MSB (bit 7): 0 – PER measured by the application 1 – PER measured on the airlink</p> <p>Bit 6: 0 – Interpret bits 0-5 as an integer % 1 – Interpret bits 0-5 as negative exponent of 10</p> <p>LSB 6 bits (bits 0-5): PER value If bit 6 =0, [0 to 63%] PER If bit 6 =1, [1e-63 to 1] PER</p>	DSA-REQ/RSP, DSC-REQ/RSP
--------------	---	---	--------------------------

Issue B:

Add additional columns of nominal SNRs for different target BERs to Table 334:

Modulation/FEC Rate	Normalized C/N Target BER e1-6	Normalized C/N Target BER e1-4	Normalized C/N Target BER e1-5	Normalized C/N Target BER e1-7
Fast_Feedback IE	0	0	0	0
CDMA code	3	3	3	3
QPSK $\frac{1}{2}$	6	TBD	TBD	TBD
QPSK $\frac{3}{4}$	9	TBD	TBD	TBD
16QAM $\frac{1}{2}$	12	TBD	TBD	TBD
16QAM $\frac{3}{4}$	15	TBD	TBD	TBD
64QAM $\frac{1}{2}$	18	TBD	TBD	TBD
64QAM $\frac{2}{3}$	20	TBD	TBD	TBD
64QAM $\frac{3}{4}$	21	TBD	TBD	TBD
64QAM $\frac{5}{6}$	23	TBD	TBD	TBD

References

- [1] IEEE P802.16e/D12 Draft standard
- [2] IEEE 802.16-2004 Standard
- [3] IEEE P802.16-2004/Cor1/D5 Draft Standard
- [4] IEEE P802.16g baseline document http://ieee802.org/16/netman/docs/80216g-05_008r1.pdf