

Project	IEEE 802.16 Broadband Wireless Access Working Group < http://ieee802.org/16 >
Title	Amendment to Location Update Primitives in 14.2.4.3
Date Submitted	2007-03-1308
Source(s)	JeeHyeon Na, Jaesun Cha, Jung-Mo Moon and Sangho Lee jhna@etri.re.kr ETRI 161 Gajeong-dong, Yuseong-gu Daejeon 305-700 Korea
Re:	Contribution on comments to IEEE 802.16g/D8
Abstract	Re-definition of location update service primitives in section 14.2.4.3
Purpose	Adoption
Notice	This document has been prepared to assist IEEE 802.16. It is offered as a basis for discussion and is not binding on the contributing individual(s) or organization(s). The material in this document is subject to change in form and content after further study. The contributor(s) reserve(s) the right to add, amend or withdraw material contained herein.
Release	The contributor grants a free, irrevocable license to the IEEE to incorporate text contained in this contribution, and any modifications thereof, in the creation of an IEEE Standards publication; to copyright in the IEEE's name any IEEE Standards publication even though it may include portions of this contribution; and at the IEEE's sole discretion to permit others to reproduce in whole or in part the resulting IEEE Standards publication. The contributor also acknowledges and accepts that this contribution may be made public by IEEE 802.16.
Patent Policy and Procedures	The contributor is familiar with the IEEE 802.16 Patent Policy and Procedures (Version 1.0) < http://ieee802.org/16/ipr/patents/policy.html >, including the statement "IEEE standards may include the known use of patent(s), including patent applications, if there is technical justification in the opinion of the standards-developing committee and provided the IEEE receives assurance from the patent holder that it will license applicants under reasonable terms and conditions for the purpose of implementing the standard." Early disclosure to the Working Group of patent information that might be relevant to the standard is essential to reduce the possibility for delays in the development process and increase the likelihood that the draft publication will be approved for publication. Please notify the Chair < mailto:r.b.marks@ieee.org > as early as possible, in written or electronic form, of any patents (granted or under application) that may cover technology that is under consideration by or has been approved by IEEE 802.16. The Chair will disclose this notification via the IEEE 802.16 web site < http://ieee802.org/16/ipr/patents/notices >.

Amendment to Location Update Service Primitives in 14.2.4.3

JeeHyeon Na, Jaesun Cha, Jungmo Moon and Sangho Lee

ETRI

1. Motivation

In current D8 document, there are only defined service primitives and figures between an 802.16 entity (BS) and an NCMS on the BS side in section 14.2.4.3, but not defined it between an 802.16 entity (MS) and an NCMS on the MS side.

However, the service primitives between an 802.16 entity (MS) and an NCMS on MS side are needed because an NCMS on MS side can generate location update service primitives to the MS.

Therefore, we modify the figure 484 and some related texts to be included service primitives between an 802.16 entity (MS) and an NCMS on MS side in this contribution.

2. Proposed Text Changes

[Modify subclause 14.2.4.3 as follows]

14.2.4.3 Location update procedure

Location management of an MS is performed by mobility management service of the NCMS. An MS in idle mode performs Location Update in order to inform the NCMS of its current location information, i.e., paging group. This information is used to page the MS through the cells that belong to the paging group of the called MS when there is pending DL traffic toward the MS.

Location Update is performed if any of the Location Update conditions are met. There are currently four Location Update conditions defined: Zone Update, Timer Update, Power Down Update and MAC Hash Skip Threshold Update. In Zone Update, the MS shall perform Location Update process when the MS detects a change in paging group by comparing the Paging Group identifier (PG_ID) stored in the MS with that of transmitted by the preferred BS in the DCD message or MOB_PAG-ADV broadcasting message. In Timer Update, MS shall periodically perform Location Update process prior to the expiration of the idle mode timer. In Power Down Update, the MS shall attempt to complete a Location Update once as part of its orderly power down procedure. In MAC Hash Skip Threshold update, the MS shall perform Location Update process when the MS MAC hash skip counter exceeds the MAC hash skip threshold.

All the above Location Updates are realized by Ranging request/response (RNG-REQ/RSP) message between an MS and a BS, and the C-PG-REQ, C-PG-RSP, C-PG-IND service primitives are defined between ~~a BS~~ an 802.16 entity and the NCMS to perform Location Update.

Figure 484 shows service primitives for Location Update between an 802.16 entity ~~a BS~~ and the NCMS.

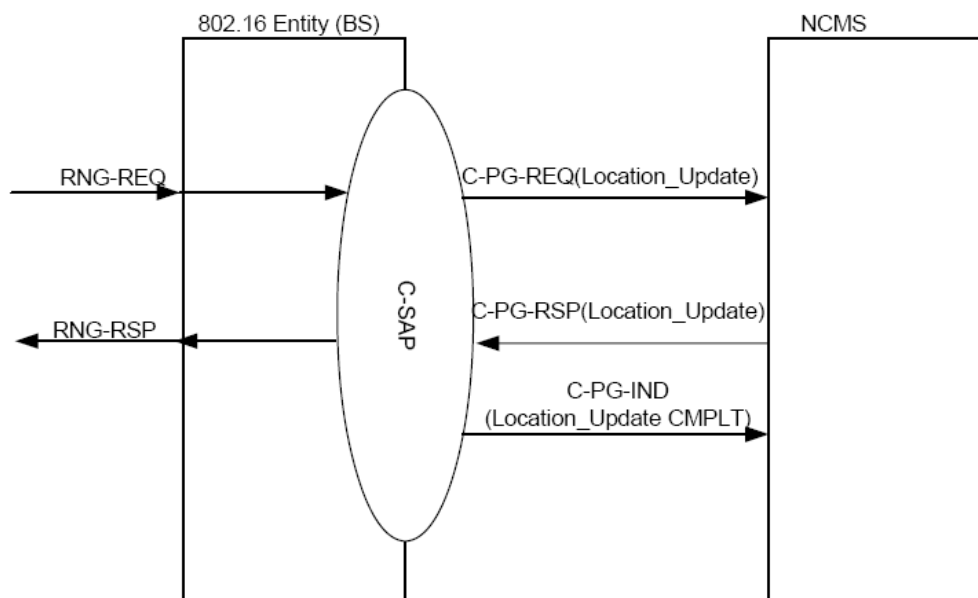

Figure 484 – Location Update Primitives

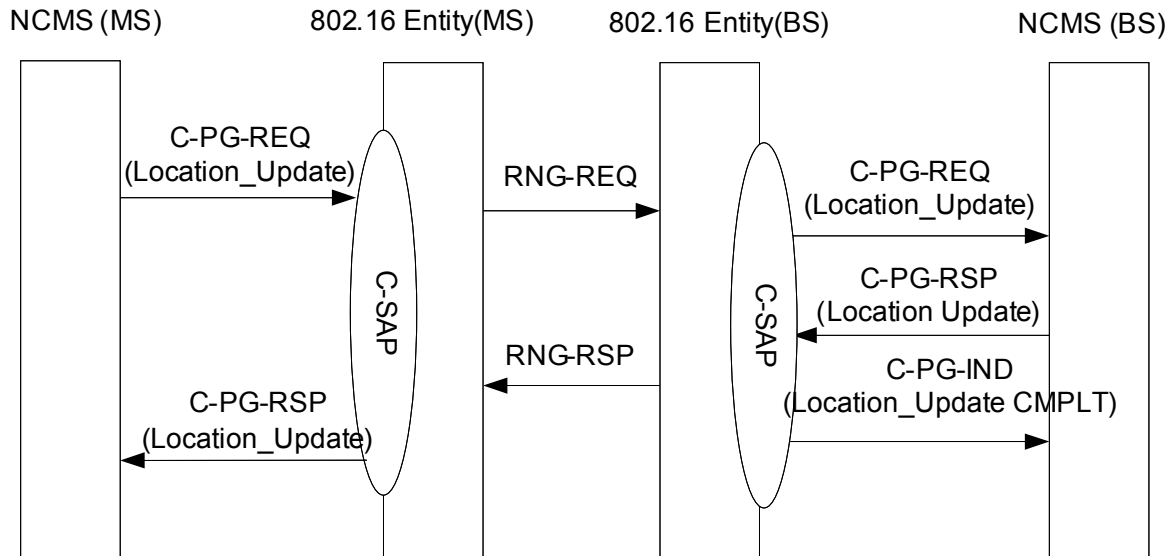

Figure 484 – Location Update Primitives

14.2.4.3.1 C-PG-REQ

This primitive is used by an 802.16 entity or an NCMS(MS) to trigger a location update procedure. The Operation_Type included in this primitive defines the type of location update procedure to be performed. The possible Operation_Types for this primitive are listed in Table below:

Action_Type	Description
Location Update	Location Update Request

Function:

This primitive is issued by a BS to inform the Mobility Management entity in the NCMS that an MS requests to initiate a Location Update procedure.

Semantics of the service primitive:

The parameters of the primitives are as follows:

C-PG-REQ

(
 Operation_Type: Action,
 Action_Type: Location Update,
 Destination: MS_NCMS,
 Attribute_List:
 MS MAC Address,
 BSID,
 Paging Controller ID,
 Paging Group ID,
 MAC Hash Skip Threshold,
 Power Down Indicator,
 Security Context Indication
)

MS MAC Address

48-bit MAC address which identifies MS

BSID

Identifier of serving BS

Paging Controller ID

The Paging Controller ID is a logical network identifier for the serving BS or other network entity retaining MS service and operational information and/or administering paging activity for the MS while in Idle Mode.

Paging Group ID

One or more logical affiliation groupings of BS

MAC Hash Skip Threshold

Maximum number of successive MOB_PAG-ADV messages that may be sent from a BS without individual notification for an MS, including MAC address hash of an MS for which Action Code is 00, 'No Action Required'.

Power Down Indicator

Indicates the MS is currently attempting to perform Location Update due to power down.

Security Context Indication

Indicates whether the BS has the required security context information for secure location update.

0x00= no security information available

0x01= security information present

When generated:

This primitive is generated by an NCMS(MS) which want to request location update by location update condition. This primitive is also generated when an 802.16 entity(BS)the BS receives RNG-REQ message with Paging Controller ID and Ranging Purpose Indication with bit #1 set to 1, MAC Hash Skip Threshold, Power Down Indicator, and Security Context Indication.

Effect of receipt:

The 802.16 entity(MS) receiving C-PG-REQ(Location Update) from the NCMS(MS) shall generate RNG-REQ message with the appropriate parameters setting. This primitive shall be generated on BS side and The NCMS(BS) which is a management entity of Mobility Management Services shall respond to this primitive by sending Location Update response-C-PG-RSP(Location Update).

14.2.4.3.2 C-PG-RSP

This primitive is used by NCMS or 802.16 entity(MS) to respond to a location update procedure. The Operation_Type included in this primitive defines the type of location update procedure to be performed. The possible Operation_Types for this primitive are listed in Table below:

Action_Type	Description
Location Update	Location Update Response

Function:

This primitive is issued by the NCMS to respond to Location Update request from the 802.16 entity.

Semantics of the service primitive:

The parameters of the primitives are as follows:

C-PG-RSP

(

Operation_Type: Action,
 Action_Type: Location Update,
 Destination: BS, **NCMS**,
 Attribute_List:
 MS MAC Address,
 Location Update Result,
 Paging Information,
 Paging Controller ID,

MAC Hash Skip Threshold,
Power Down Response,
Security Information

)

MS MAC Address

48-bit MAC address which identifies MS

Location Update Result

Response to Location Update Request:

0b00=Failure. The MS shall perform Network Re-entry from Idle Mode;

0b01=Successful assignment of Paging Controller and Paging Information.

0b10, 0b11: Reserved

Paging Information

New Paging Information assigned to MS. Paging Information shall only be included if Location Update Response=0x01 and if Paging Information has changed. The Paging Information TLV defines the Paging Group ID, PAGING_CYCLE and PAGING_OFFSET parameters to be used by the MS in IDLE mode. PAGING_CYCLE is the cycle in which the paging message is transmitted within the paging group. PAGING_OFFSET determines the frame within the cycle in which the paging message is transmitted and it must be smaller than PAGING_CYCLE value. Paging Group ID specifies the paging group the MS is assigned to.

Paging Controller ID

Paging Controller ID is a logical network identifier for the serving BS or other network entity retaining MS service and operational information and/or administering paging activity for the MS while in Idle Mode. Paging Controller ID shall only be included if Location Update Response=0x01 and if Paging Controller ID has changed.

MAC Hash Skip Threshold

Maximum number of successive MOB_PAG-ADV messages that may be sent from a BS without individual notification for an MS, including MAC address hash of an MS for which Action Code for the MS is 00,'No Action Required'. If BS does not include this TLV item in the RNG-RSP message, any BS may omit MAC Address Hash of the MS with Action Code 00,'No Action Required' from any MOB_PAG-ADV message.

Power Down Response

Indicates the MS's Power Down Location Update result.

0x00= Failure of Power Down Information Update.

0x01= Success of Power Down Information Update.

Security Information

The information which can be used by BS to implement authentication procedure. This Information is optional and it is only included when Security Context Indication = 0x00 in C-PG-REQ. (The BS does not have required security context information and needs to obtain it from the NCMS for secure location update.)

When generated:

This primitive is generated at the NCMS in order to request an [802.16 entity \(-BS\)](#) to issue a RNG-RSP message. [This primitive is also generated at an 802.16 entity\(MS\) to inform the NCMS\(MS\)- of the location update response.](#)

Effect of receipt:

[The 802.16 entity \(A-BS\)](#) receiving [C-PG-RSP\(Location Update\)-response](#) shall transmit RNG-RSP message with the appropriate parameters settings. [The NCMS receiving C-PG-RSP\(Location Update\) shall complete the location update procedures.](#)