Project	IEEE 802.16 Broadband Wireless Access Working Group < http://ieee802.org/16 >	
Title	MR Relay Link (R-link) and Access link monitoring and reporting procedure for Multi-hop path selection	
Date Submitted	2007-04-30	
Source(s)	<p>G.Q. Wang, Wen Tong, Peiyong Zhu Hang Zhang, David Steer, Gamini Senarath, Derek Yu</p> <p>Nortel 3500 Carling Avenue Ottawa, Ontario K2H 8E9</p> <p>Yukihiro Takatani, Seishi Hanaoka</p> <p>Hitachi, Ltd. 292, Yoshida-cho, Totsuka-ku, Yokohama-shi, Kanagawa 244-0817, Japan</p> <p>Kanchei (Ken) Loa, Yi-Hsueh Tsai, Shiann-Tsong Sheu, Hua-Chiang Yin, Yung-Ting Lee, Chih-Chiang Hsieh, Frank C.D. Tsai, Youn-Tai Lee, Heng-Iang Hsu</p> <p>Institute for Information Industry 8F., No. 218, Sec. 2, Dunhua S. Rd., Taipei City, Taiwan</p> <p>Kevin Baum, Mark Cudak, Philippe Sartori, Eugene Visotsky</p> <p>Motorola Labs 1301 E. Algonquin Road, Schaumburg, IL 60196 USA</p> <p>Shyamal Ramachandran</p> <p>Motorola Inc. 1064 Greenwood Blvd. Suite 400</p>	<p>Voice: 1-613-763-1315 [mailto:wentong@nortel.com]</p> <p>yukihiro.takatani.ee@hitachi.com</p> <p>seishi.hanaoka.kw@hitachi.com</p> <p>Voice: +886-2-2739-9616 loa@iii.org.tw</p> <p>eugenev@motorola.com</p> <p>shyamal.ramachandran@motorola.com</p>

Lake Mary, FL 32746 USA

Ki Seok Kim, Hyunjae Kim,
Sungcheol

Voice:+82-42-860-5481

Fax: +82-42-861-1966

Chang, Young-il Kim

Email: khjgo@etri.re.kr

ETRI

161,Gajeong-Dong,Yuseung-Gu,
Daejeon,

Korea 205-350

Kyu Ha Lee, Changkyoon Kim

Voice:+82-31-280-9917

Samsung Thales

Fax: +82-31-280-1620

San 14, Nongseo-Dong, Giheung-Gu,

Email: kyuha.lee@samsung.com

Yongin, Gyeonggi-Do, Korea 449-
712

Yousuf Saifullah, Shashikant
Maheshwari,

Voice: +1(0) 972 894 5000

Haihong Zheng

Email: Yosuf.saifullah@nokia.com

Nokia

6000 Connection Drive, Irving, Tx

Aik Chindapolk, Jimmy Chui, Hui
Zeng

Voice: +1 609 734 3364

Siemens Corporate Research

Fax: +1 609 734 6565

755 College Road East, Princeton,
NJ, USA

Email: aik.chindapol@siemens.com

Chenxi Zhu

Voice : 1-301-486-0671

Fujitsu Labs of America

Email : chenxi.zhu@us.fujitsu.com

8400 Baltimore Ave., 302

College Park, MD, USA

Re: Response to a call for contributions.

Abstract Harmonization of IEEE C802.16j-07/213r1, C802.16j-07/225r1 and C802.16j-07/259r1.

Purpose To make MR-BS collectively acquire the current status of all relay links and access links in MR network

Notice This document has been prepared to assist IEEE 802.16. It is offered as a basis for discussion and is not binding on the contributing individual(s) or organization(s). The material in this document is subject to change in form and content after further study. The contributor(s) reserve(s) the right to add, amend or withdraw material contained herein.

Release The contributor grants a free, irrevocable license to the IEEE to incorporate material contained in this contribution, and any modifications thereof, in the creation of an IEEE Standards publication; to copyright in the IEEE's name any IEEE Standards publication even though it may include portions of this contribution; and at the IEEE's sole discretion to permit others to reproduce in whole or in part the resulting IEEE Standards publication. The contributor also acknowledges and accepts that this contribution may be made public by IEEE 802.16.

Patent Policy and Procedures The contributor is familiar with the IEEE 802.16 Patent Policy and Procedures <<http://ieee802.org/16/ipr/patents/policy.html>>, including the statement "IEEE standards may include the known use of patent(s), including patent applications, provided the IEEE receives assurance from the patent holder or applicant with respect to patents essential for compliance with both mandatory and optional portions of the standard." Early disclosure to the Working Group of patent information that might be relevant to the standard is essential to reduce the possibility for delays in the development process and increase the likelihood that the draft publication will be approved for publication. Please notify the Chair <<mailto:chair@wirelessman.org>> as early as possible, in written or electronic form, if patented technology (or technology under patent application) might be incorporated into a draft standard being developed within the IEEE 802.16 Working Group. The Chair will disclose this notification via the IEEE 802.16 web site <<http://ieee802.org/16/ipr/patents/notices>>.

MR Relay Link (R-link) and Access link monitoring and reporting procedure for Multi-hop path selection for MS

G.Q. Wang, Wen Tong, Peiyong Zhu, Hang Zhang, Gamini Senarath,

David Steer, Derek Yu, Nortel

Yukihiro Takatani, Seishi Hanaoka, Hitachi, Ltd

Kanchei (Ken) Loa, Yi-Hsueh Tsai, Shiann-Tsong Sheu, Hua-Chiang Yin, Yung-Ting Lee, Chih-Chiang Hsieh, Frank C.D. Tsai, Youn-Tai Lee, Heng-Iang Hsu, Institute for Information Industry

Kevin Baum, Mark Cudak, Philippe Sartori, Eugene Visotsky, Motorola Labs

Shyamal Ramachandran, Motorola Inc.

Ki Seok Kim, Hyunjae Kim, Sungcheol Chang, Young-il Kim, ETRI

Kyu Ha Lee, Changkyoon Kim, Samsung Thales

Yousuf Saifullah, Shashikant Maheshwari, Haihong Zheng, Nokia

Aik Chindapolk, Jimmy Chui, Hui Zeng, Siemens Corporate Research

Chenxi Zhu, Fujitsu

Introduction

In 802.16j system, a multi-hop path selection is one of the important functionalities for the efficient usage of radio resource in the network. To be able to select an optimal relay path from BS to the access RS, and furthermore to the MS, MR routing control system needs to collectively acquire global air link status within a cell. This contribution does not specify a particular link metric to be used for path selection. As an example, a route stability metric is considered.

More specifically, as MS relies on the legacy 802.16e network entry and handover procedures, the following routing inefficiencies are likely to arise in an MR network.

An MS detects a stronger preamble signal from an RS and proceeds to establish network attachment through that RS. However, a path through another RS with a lower preamble signal strength may be overall a higher quality route than the chosen path.

An MS detects a stronger preamble from the BS than from an RS and proceeds to establish direct UL and DL links with the BS. This network attachment decision is optimum with respect to the DL communication. However, as the transmit power of the BS may be significantly higher than that of the RS, pathloss on the MS-to-BS link may still be significantly higher than that on the MS-to-RS link. In this case, the network entry decision by the MS may be suboptimum with respect to the UL communication.

In this contribution, new signaling procedures are proposed to enable appropriate route selection for the MS upon its entry into an IEEE 802.16j network or handover into a new cell. Also, a procedure is proposed for establishing efficient routes between the MR-BS and RSs in its cell.

Background

In IEEE 802.16e-2005 standard, there are mechanisms to measure and acquire the quality of radio link at the physical layer. Examples of link quality parameters are shown in Table 1. These parameters can be used by BS for monitoring the status of BS-MS links, and for the purpose of handover, scheduling, and so on.

Table 1 Link quality parameters in IEEE 802.16e-2005 standard

Link quality parameter	Mechanism to report link quality parameters
DL RSSI mean	REP-RSP message
DL RSSI standard deviation	
DL CINR mean	
DL CINR standard deviation	
DL CQI value	fast-feedback channel (CQICH)
Neighbor DL CINR mean	MOB_SCN-REP message
Neighbor DL RSSI mean	

Note that the MOB_SCN-REP message can be used to report the neighbor DL RSSI or CINR measurements.

In general, the radio link quality changes in time (The word “link quality” is used here as a meaning of SINR or CINR level). A fluctuation of link quality may occur because of movement of nodes, environmental factors (radio noise, obstacles, weather condition, etc.), or system failure (node/card failure).

The example of 802.16j system is shown in Figure 1. The link quality between MR-BS and RS1 slightly fluctuates in time, but the one between MR-BS and RS2 dramatically changes. In this case the former link can be regarded as a stable radio link, and the latter one as a unstable radio link. Therefore it is appropriate to select the path via RS1.

In 802.16j system, a multi-hop path selection, which is defined as an optional functional requirement, is an important functionality for the efficient usage of radio resource in the network. To select an appropriate path, the stability of link quality could be considered, as well as other routing metrics.

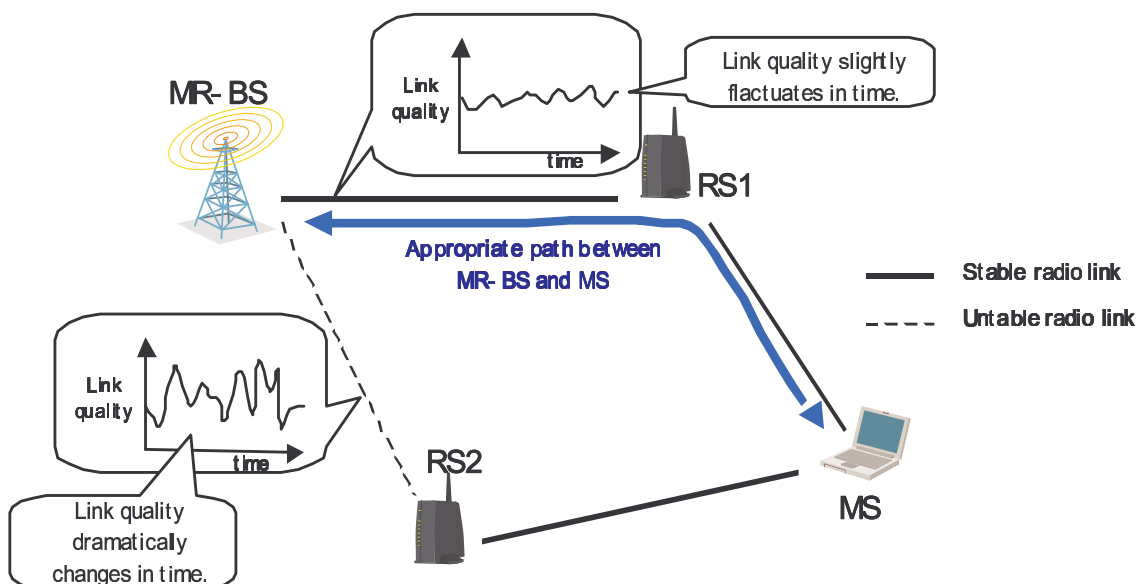

Figure 1 An appropriate path selection based on stability of link quality in 802.16j system

As indicated in Table 1, 802.16e-2005 has defined two ways to monitor and report the access link quality status: MS can use REP-RSP message or CQICH channel to report the measured link metrics to BS. Furthermore, the neighbor measurements could be reported via the MOB_SCN-REP message. The following sections propose link status report/procedure extensions to R-link quality metrics (both R-DL and R-UL). The extensions include new TLV and procedures to report link status and to select the relay path with the associated link metrics. Furthermore, procedures for reporting access link quality metrics and selecting and optimized MR-BS-to-MS routes are also proposed.

Example of path selection based on stability metric

In general, a number of routing metrics could be used. One possibility is to use the stability of link quality as a metric of multi-hop path selection. There are advantages to considering it:

Less frequent path changes: It can reduce the control overhead occurring by path changes.

Less data loss: It can avoid data loss by a sudden decrease of link quality.

Link quality for backup relay path purpose (reliability)

In order to get information regarding the stability of link quality, following methods are proposed:

Using a fast-feedback channel (CQICH)

Using REP-RSP messages (In case that CQICH cannot be used) with newly introduced R-link TLV
MOB_SCN-REP messages for reporting DL neighbor information on the access link

In these methods, no change of MS specification is required.

Calculating the stability of link quality using a fast-feedback channel (CQICH)

In the centralized scheduling, MR-BS may allocate CQICH to RSs and MSs in its cell (Figure 2). Allocation of CQICH for RSs is performed in the relay zone. For MSs, CQICH is allocated in the access zone on the access link hop, and could be allocated in the relay zone on subsequent hops. Therefore, an RS may send to MR-BS CQI received from an MS in the access zone through a corresponding CQICH channel in the relay zone. RSs and MSs report CQI to MR-BS, and MR-BS maintain the history of CQI. Based on this information, it may calculate the stability of link quality which is used for the multi-hop path selection. The algorithm of calculating the stability of link quality is out of scope of this contribution.

As CQICH only reports CQI information for DL transmission from parent nodes, REP-RSP messages with the newly introduced R-Link TLV may be used to report neighbor measurement information for relay links.

MOB_SCN-REP message can be used to report DL MS neighbor measurements from an MS to the access RS, and these access link neighbor measurements may be reported to the MR-BS in the newly introduced Access-Link TLV.

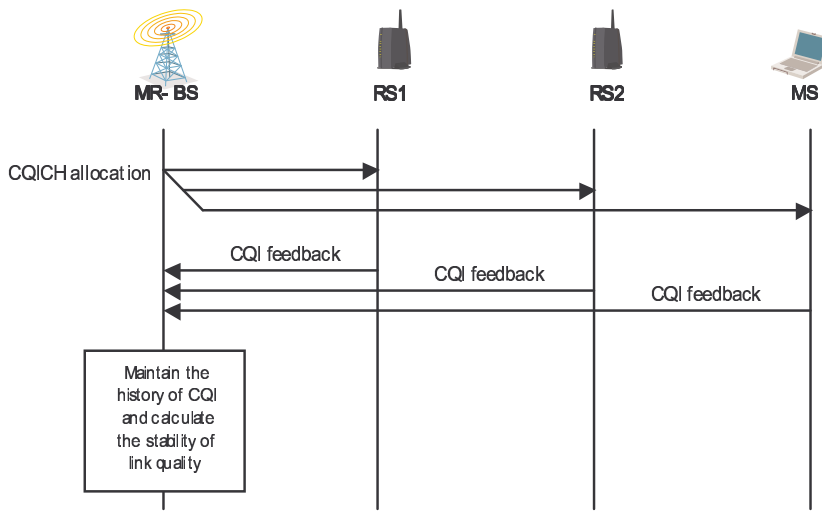

Figure 2 Using a fast-feedback channel (CQICH): Centralized scheduling

In the distributed scheduling, MR-BS and RSs allocate CQICH to neighboring RSs and MSs (Figure 3). Allocation of CQICH for RSs is performed in the relay zone and the one for MSs in the access zone. MR-BS and RSs collect CQI from neighboring nodes and maintain the history of CQI. Based on this information, they calculate the stability of link quality which is used for the multi-hop path selection. The algorithm of calculating the stability of link quality is out of this contribution.

As CQICH only reports CQI information for DL transmission from parent nodes, REP-RSP messages with the newly introduced R-Link TLV may be used to report neighbor measurement information for relay links. MOB_SCN-REP message can be used to report DL MS neighbor measurements from an MS to the access RS, and these access link neighbor measurements may be reported to the MR-BS in the newly introduced Access-Link TLV.

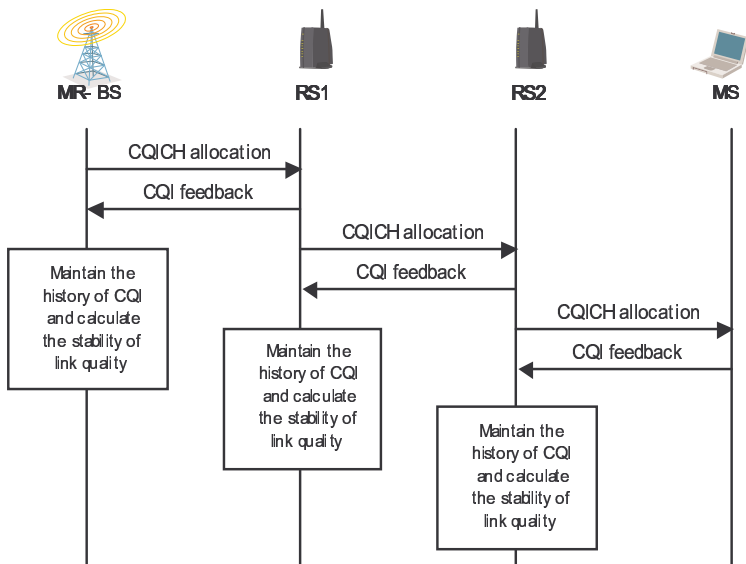

Figure 3 Using a fast-feedback channel (CQICH): Distributed scheduling

Calculating the stability of link quality using REP-RSP messages

If the fast-feedback channel (CQICH) cannot be used, REP-RSP messages may be used, alternatively.

In the centralized scheduling, MR-BS sends REP-REQ to RSs and MSs, requesting a RSSI standard deviation or a CINR standard deviation, and RSs and MSs send REP-RSP to MR-BS (Figure 4). While MS only reports single Down-Link status (from BS to MS, as defined in 802.16e-2005) to the BS, each designated RS should report multiple link status including both R-DL (from BS or ancestor RS to the designated RS) and R-UL (from the successor RS to the designated RS) to the BS. The REP-RSP issued from each RS should indicate the link direction (i.e., R-DL, R-UL or neighbor measurement), and the source of the measured transmission (i.e., the identity of the Relay amble measured). Note that MS neighbor measurements could be obtained from MS via the MOB_SCN-REP messages.

RS shall report the measured channel conditions (both R-DL and R-UL) to MR BS via either polling (REP-REQ/RSP) or via unsolicited responses (REP-RSP).

MR-BS may use the value of a RSSI standard deviation or a CINR standard deviation directly as a measure of the stability of a link quality.

With the collectively acquired link status, MR BS would effectively schedule the radio resource, select the optimized path for the relay, and route the traffic to an alternative path when a routing failure occurs.

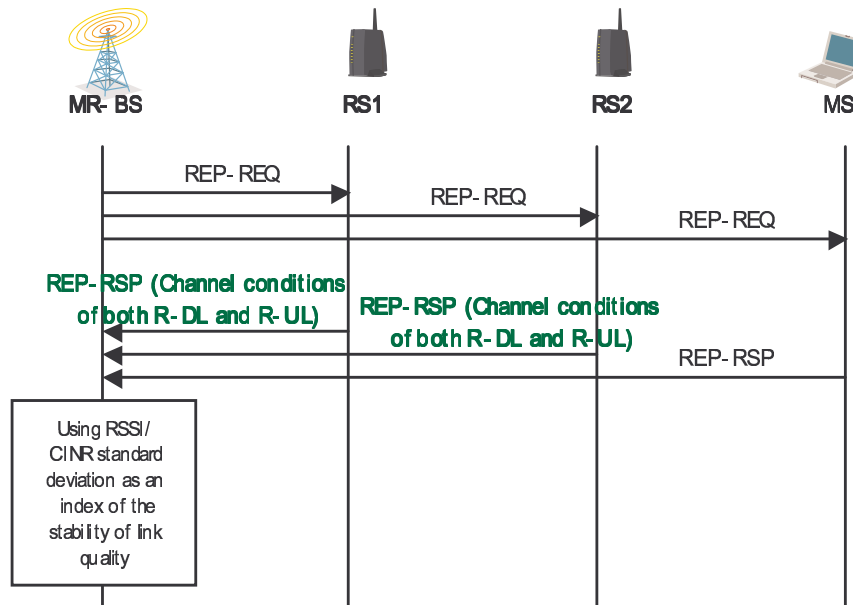

Figure 4 Using REP-RSP messages: Centralized scheduling

In the distributed scheduling, MR-BS and RSs send REP-REQ to neighboring RSs and MSs, requesting a RSSI standard deviation or a CINR standard deviation (Figure 5). They receive REP-RSP from neighboring RSs and MSs. They may use the value of a RSSI standard deviation or a CINR standard deviation directly as an index of the stability of link quality.

Each designated RS should report multiple link status including both R-DL (from BS or ancestor RS to the designated RS) and R-UL (from the successor RS to the designated RS) and R-Link neighbor measurements to the BS.

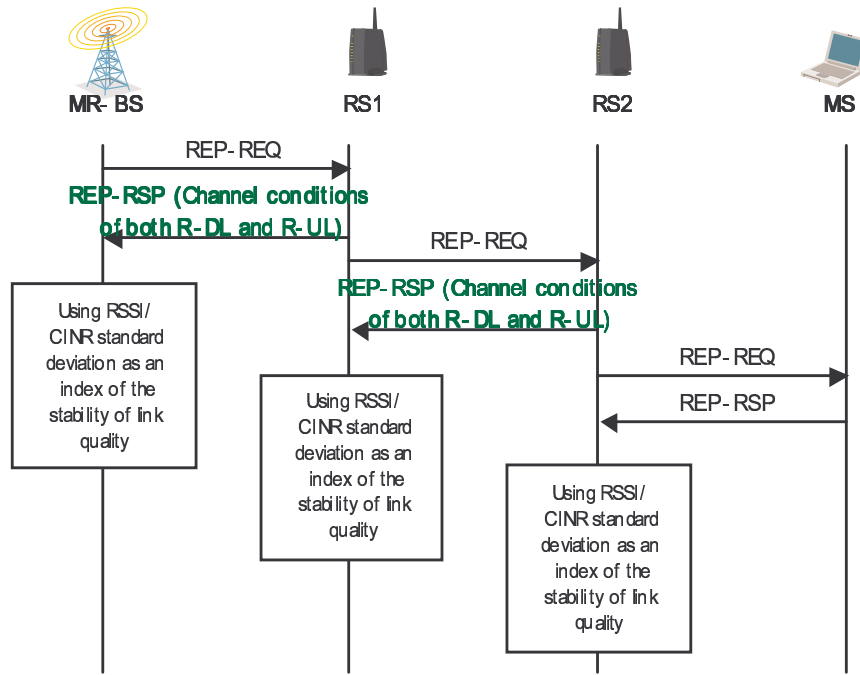

Figure 5 Using REP-RSP messages: Distributed scheduling

Example of DL path selection procedure for MS

An example of DL path selection is shown in Figure 6. In the figure, RS1 and RS2 have established a route with their superordinate BS. Specifics of the algorithm for RS route establishment are outside the scope of this contribution. In this contribution, it is proposed that the MR-BS learns of the R-Link metrics between itself and every subordinate RS via modified REP-RSP/REQ messages and utilizes this information for proper MS route selection. Returning to the example in Figure 6, it is assumed that routing metrics m_{br1} and m_{br2} , capturing route quality between MR-BS and RS1 and RS2, respectively, are computed at the MR-BS from the reported R-Link metrics in the REP-RSP messages.

Without loss of generality, let MS be initially attached to RS1 by using legacy 802.16e network entry or handover procedures. The MS then has set-up a route to the MR-BS via RS1. To check the optimality of this route, the MR-BS needs to learn the overall quality of the path via RS2 and compare it with the overall quality of the path via RS1. As m_{br1} and m_{br2} are already available at the MR-BS, only link metrics for the RS-to-MS links, m_{rm1} and m_{rm2} , are needed. Then, the overall quality metric of the i th path may be simply computed as $Q_i = m_{bm_i} + m_{rm_i}$. Note that this calculation is only an example, and details of the routing metric calculations are proprietary.

It is assumed that the MS maintains legacy 802.16e DL and UL communication links with RS1, and hence provides legacy CQI feedback to RS1. The required metric m_{rm1} can then be derived at the MR-BS from the CQI feedback provided to it by RS1. The details of this calculation are not specified in the standard. To obtain CQI for the RS1-MS link, the MR-BS queries RS1 by sending the REP-REQ message. RS1 replies with the REP-RSP message containing Access-link TLV with CQI feedback.

To obtain m_{rm2} , MR-BS relies on the 802.16e legacy handover measurements procedure at the MS. Specifically, MR-BS sends to RS1 a MOB_SCN-RSP message intended for the MS and specifying RS2 as the measurement

target in the `N_Recommended_BS_Index` message field. RS1 relays the `MOB_SCN-RSP` message to the MS and receives a `MOB_SCN-REP` message from MS containing CQI feedback for the RS2-to-MS link. RS1 forwards the message to the MR-BS which computes m_{rm2} based on the CQI reported in the message. Alternatively, neighbor measurements in the `MOB_SCN-REP` message can be reported to the MR-BS via the Access-Link TLV in the `REP-RSP` message.

Upon computing the overall quality metrics for the two paths, the MR-BS may decide to switch the MS to the path via RS2. In this case, it will transmit a `MOB_BSHO-REQ` message to RS1, specifying RS2 as the mandatory handover target. RS1 will relay the message to the MS, initiating handover process. Bounce diagram for this process is shown in Figure 7.

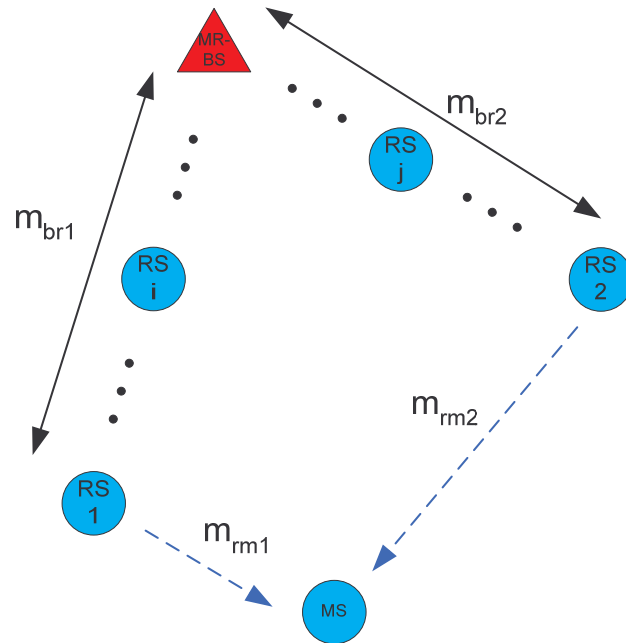

Figure 6. MS route determination in Scenario 1.

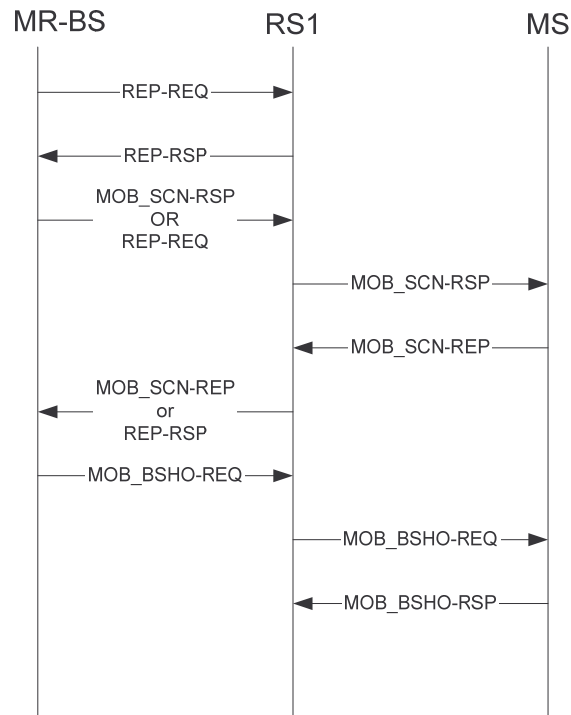

Figure 7. Signaling diagram for Scenario 1

Proposed text changes

6.3.25 Relay path management and routing

[Insert the following text]

6.3.25.x R-link monitoring and reporting procedure for relay path management

Computation at the MR-BS of the end-to-end route quality metric for the multihop path between the MR-BS and an RS in its cell may, optionally, be enabled. Optionally, the stability of link quality may be considered as a metric for multi-hop path selection. A route quality metric may be derived at the MR-BS based on link measurements obtained from a CQI fast-feedback channel (CQICH) and/or from a REP-RSP message carrying an R-link TLV.

In the case of centralized scheduling, MR-BS may allocate CQICH to an RS in its cell for reporting CQI on DL transmissions originating at RS's ancestor RS or MR-BS. Allocation of CQICH for RSs is performed in the relay zone.

In the case of distributed scheduling, MR-BS and each RS in an MR cell may allocate CQICH to a downstream RS. Allocation of CQICH for an RS is performed in the relay zone.

To report R-UL, R-DL and R-Link neighbor measurements, REP-RSP messages with R-Link TLV may optionally be used. An MR-BS may send a REP-REQ message to an RS in its cell requesting RSSI mean and standard deviation or CINR mean and standard deviation measurements. The RS may respond with a REP-RSP message containing R-Link TLV and requested measurements. MR-BS may use the reported measurements for route quality calculations, and optionally for computing the stability of a route.

[Insert the following text]

6.3.25.x+1 Access-link monitoring and reporting procedure for MS path management

Computation at the MR-BS of the overall quality metric for the multihop path between the MR-BS and an MS in its cell may, optionally, be enabled. The multihop path between the MR-BS and an MS can be decomposed into two path segments. The first path segment is the multihop path between the MR-BS and the access RS of the MS. The second path segment is the access link between the MS and the access RS. To enable routing metric computation at the MR-BS, R-link metrics shall be reported to the MR-BS in REP-RSP message containing R-Link TLV, and access link metrics may optionally be reported to the MR-BS in the REP-RSP message containing Access-Link TLV. The REP-RSP message may be sent to the MR-BS in response to REP-REQ message or by sending an unsolicited REP-RSP message. Access-link measurements at an MS may optionally be triggered by sending a MOB_SCN-RSP message (Section 6.3.2.3.49) to the MS. The access-link measurements shall be reported by the MS to the access RS or MR-BS in the MOB_SCN-REP message (Section 6.3.2.3.50).

To enable DL CQI reporting, MR-BS may allocate CQICH to MSs in its cell. CQICH is allocated in the access zone on the access link hop, and may optionally be allocated in the relay zone on subsequent hops. Therefore, an RS may send to MR-BS CQI received from an MS in the access zone through a corresponding CQICH in the relay zone. A fast feedback region for reporting MS CQI values in the relay zone to the MR-BS may be allocated by sending, in a unicast manner, a FAST-FEEDBACK allocation IE (subclause 8.4.5.4.9) to an RS. Fast feedback slot assignments in this region shall be the same as those in the CQI fast feedback region in the RS access zone.

The UL and DL routes may optionally be different for the same MS.

[Insert the following text at the end of Section 11.12]

An R-Link TLV may optionally be included in the REP-RSP message to report CQI information for relay links. The proposed R-Link TLV format is as follows. In 802.16-2005, preamble is defined an 8-bit integer. Similar convention is used to index Relay-amble. Direction is specified as two bits.

Name	Type	Length	Value
R-Link	7	2 bytes	16-bit Integer

Syntax	Size	Notes
R-Link{		
Direction	2 bits	0b00 = Reserved 0b01 = Uplink 0b10 = Downlink 0b11 = Neighbor measurement
Reserved	6 bits	
Source	8 bits	Relay amble index
}		

[Insert the following text at the end of Section 11.12]

An Access-Link may optionally be included in the REP-RSP message to report DL CQI information for access links. The Access-Link TLV format is as follows. MS CID specifies the identity of the MS for which the measurements are reported. Relay amble index is used to index the DL MS channel measurements.

Syntax	Type	Length	Notes
Access-Link{			
CID	8.1	2	CID of MS being reported
Source	8.2	N	Relay amble indices for which measurements are reported
DL CINR Report	8.3	N	CINR report for each relay index
DL SINR Report	8.4	N	SINR report for each relay index
}			

References

- [1] IEEE standard 802.16e-2005, " IEEE Standard for Local and metropolitan area networks, Part 16: Air Interface for Fixed Broadband Wireless Access Systems"
- [2] IEEE 802.16j-06/013r3, "Multi-hop Relay System Evaluation Methodology (Channel Model and Performance Metric)"
- [3] IEEE 802.16j-06/014r1, "Harmonized definitions and terminology for 802.16j Mobile Multihop Relay"
- [4] IEEE 802.16j-06/015, "Harmonized Contribution on 802.16j (Mobile Multihop Relay) Usage Models"
- [5] IEEE 802.16j-06/016r1, "Proposed Technical Requirements Guideline for IEEE 802.16 Relay TG"
- [6] IEEE 802.16j-06/017r2, "Table of Contents of Task Group Working Document"
- [7] IEEE 802.16j-06/026r2, "P802.16j Baseline Document"
- [8] IEEE 802.16j-06/248r2, "R-link TLV for MMR relay link monitoring and reporting procedure"
- [9] IEEE 802.16j-07/079, "A new metric for multi-hop path selection"
- [10] IEEE 802.16j-07/229r5, "Interference detection and Measurement in OFDMA Relay Networks"
- [11] IEEE 802.16j-07/225r1, "Signaling for Efficient MS Routing"
- [12] IEEE 802.16j-07/259r1, "The 2nd fast feedback channel region to reduce transfer delay of fast feedback data for 2-hop MR system"