

<b>Project</b>	<b>IEEE 802.16 Broadband Wireless Access Working Group</b>	
<b>Title</b>	Signaling for Efficient MS Routing	
<b>Date:</b>	03-05-2007	
<b>Source(s)</b>	Kevin Baum Mark Cudak Philippe Sartori Eugene Visotsky <a href="mailto:eugenev@motorola.com">eugenev@motorola.com</a> Motorola Labs 1301 E. Algonquin Road, Schaumburg, IL 60196 USA	Shyamal Ramachandran <a href="mailto:shyamal.ramachandran@motorola.com">shyamal.ramachandran@motorola.com</a> Motorola Inc. 1064 Greenwood Blvd. Suite 400 Lake Mary, FL 32746 USA
<b>Re:</b>	This document is in response to call for technical proposals IEEE 80216j-07/007r2 dated 19 February 2007. This document proposes text regarding signaling for efficient routing for insertion in baseline document IEEE 80216j-06/026r2.	
<b>Abstract</b>	This contribution proposes signaling for efficient routing of MS with multihop relays in an IEEE 802.16j system. This contribution also provides the technical rationale for the proposed signaling.	
<b>Purpose</b>	Text is included for insertion in the IEEE 802.16j amendment to the standard.	
<b>Notice</b>	This document has been prepared to assist IEEE 802.16. It is offered as a basis for discussion and is not binding on the contributing individual(s) or organization(s). The material in this document is subject to change in form and content after further study. The contributor(s) reserve(s) the right to add, amend or withdraw material contained herein.	
<b>Release</b>	The contributor grants a free, irrevocable license to the IEEE to incorporate material contained in this contribution, and any modifications thereof, in the creation of an IEEE Standards publication; to copyright in the IEEE's name any IEEE Standards publication even though it may include portions of this contribution; and at the IEEE's sole discretion to permit others to reproduce in whole or in part the resulting IEEE Standards publication. The contributor also acknowledges and accepts that this contribution may be made public by IEEE 802.16.	
<b>Patent Policy and Procedures</b>	The contributor is familiar with the IEEE 802.16 Patent Policy and Procedures < <a href="http://ieee802.org/16/ipr/patents/policy.html">http://ieee802.org/16/ipr/patents/policy.html</a> >, including the statement "IEEE standards may include the known use of patent(s), including patent applications, provided the IEEE receives assurance from the patent holder or applicant with respect to patents essential for compliance with both mandatory and optional portions of the standard." Early disclosure to the Working Group of patent information that might be relevant to the standard is essential to reduce the possibility for delays in the development process and increase the likelihood that the draft publication will be approved for publication. Please notify the Chair < <a href="mailto:chair@wirelessman.org">mailto:chair@wirelessman.org</a> > as early as possible, in written or electronic form, if patented technology (or technology under patent application) might be incorporated into a draft standard being developed within the IEEE 802.16 Working Group. The Chair will disclose this notification via the IEEE 802.16 web site < <a href="http://ieee802.org/16/ipr/patents/notices">http://ieee802.org/16/ipr/patents/notices</a> >.	

# Signaling for Efficient MS Routing

*K. Baum, M. Cudak, S. Ramachandran, P. Sartori, E. Visotsky*

*Motorola*

## Introduction

In the IEEE 802.16j standard, Relay Stations (RS) are introduced to improve coverage, extend range and enhance capacity of the IEEE 802.16e cellular systems. In the scope of the IEEE 802.16j, introduction of relays into an IEEE 802.16e network is to be seamless with respect to the Subscriber Station (SS)/Mobile Station (MS) operation. To satisfy the backwards compatibility requirement with IEEE 802.16e, a Relay Station (RS) must appear as a complete BS to an MS by broadcasting its own 802.16e preamble and UL/DL control information. In an IEEE 802.16j network, this preamble and control information will be utilized by MS for network entry and handover processes as already standardized for 802.16e networks. However, an 802.16e network is a single-hop network with all over-the-air transmissions sent directly between a BS and its subordinate MS. When used in a multi-hop topology of an 802.16j system, it is likely that these legacy network entry and handover procedures will lead to suboptimum network attachment decisions at an MS, since these procedures are not designed to take into account the overall quality of routes for various MS network attachment options. Specifically, consider the following two examples of the legacy 802.16e network attachment procedures leading to suboptimum decisions in an 802.16j network:

An MS detects a stronger preamble signal from an RS and proceeds to establish network attachment through that RS. However, a path through another RS with a lower preamble signal strength may be overall a higher quality route than the chosen path.

An MS detects a stronger preamble from the BS than from an RS and proceeds to establish direct UL and DL links with the BS. This network attachment decision is optimum with respect to the DL communication. However, as the transmit power of the BS may be significantly higher than that of the RS, pathloss on the MS-to-BS link may still be significantly higher than that on the MS-to-RS link. In this case, the network entry decision by the MS may be suboptimum with respect to the UL communication.

In this contribution, new signaling procedures and MAC management messages are proposed to enable appropriate route selection for the MS upon its entry into an IEEE 802.16j network or handover into a new cell. In particular, solutions to rectify routing configurations identified in Scenarios 1 and 2 are proposed. The proposed approach is completely transparent to a legacy 802.16e MS and relies on the existing mobility management messages defined in the IEEE 802.16e standard.

## Routing solution for Scenario 1

Routing problem for Scenario 1 is shown in Figure 1. In the figure, RS1 and RS2 have established a route with their superordinate BS. Details of the RS route establishment are outside the scope of this contribution. In this contribution, it is proposed that the MR-BS learns of the end-to-end (ETE) routing metric between itself and every subordinate RS and utilizes this information for proper MS route selection.

The MR-BS is informed of the RS ETE routing metric in the proposed RS\_Metric-REP message. This message supports two modes of the metric reporting procedure. For the first mode, it is assumed that each RS can compute its own ETE routing metric to the MR-BS by listening to the ETE routing metrics included in the routing announcements received from its neighboring RS. For the second reporting mode, it is assumed that the MR-BS itself computes the RS ETE routing metrics based on the link metrics reported to the MR-BS in the RS\_Metric-REP message. In this case, the RS\_Metric-REP message contains CQI metrics corresponding to indices of the neighbor “RS ambles” measured at an RS since the last RS metric report. Returning to the example in Figure 1, it is assumed that ETE metrics  $m_{br1}$  and  $m_{br2}$ , are known at the MR-BS by relying on either mode of the metric reporting procedure.

Without loss of generality, let MS be initially attached to RS1 by using legacy 802.16e network entry or handover procedures. The MS then has set-up a route to the MR-BS via RS1. To check the optimality of this route, the MR-BS needs to learn the ETE metric of the path via RS2 and compare it with the ETE metric of the path via RS1. As  $m_{br1}$  and  $m_{br2}$  are already available at the MR-BS, only link metrics for the RS-to-MS links,  $m_{rm1}$  and  $m_{rm2}$ , are needed. Then, the ETE metric of the  $i$ th path can be simply computed as  $ETE_i = m_{bm_i} + m_{rm_i}$ . Note that this calculation is only an example, and details of the ETE metric calculations are proprietary.

It is assumed that the MS maintains legacy 802.16e DL and UL communication links with RS1, and hence provides legacy CQI feedback to RS1. The required metric  $m_{rm1}$  can then be derived at the MR-BS from the CQI feedback provided to it by RS1. The details of this calculation are not specified in the standard. To obtain CQI for the RS1-MS link, the MR-BS queries RS1 by sending the MS\_Metric-REQ message. RS1 replies with the MS\_Metric-RSP message.

To obtain  $m_{rm2}$ , MR-BS relies on the 802.16e legacy handover measurements procedure at the MS. Specifically, MR-BS sends to RS1 a MOB\_SCN-RSP message intended for the MS and specifying RS2 as the measurement target in the N\_Recommended\_BS\_Index message field. RS1 relays the MOB\_SCN-RSP message to the MS and receives a MOB\_SCN-REP message from MS containing CQI feedback for the RS2-to-MS link. RS1 forwards the message to the MR-BS which computes  $m_{rm2}$  based on the CQI reported in the message.

Upon computing the ETE metrics for the two paths, the MR-BS may decide to switch the MS to the path via RS2. In this case, it will transmit a MOB\_BSHO-REQ message to RS1, specifying RS2 as the mandatory handover target. RS1 will relay the message to the MS, initiating handover process.

Bounce diagram for this process is shown in Figure 2.

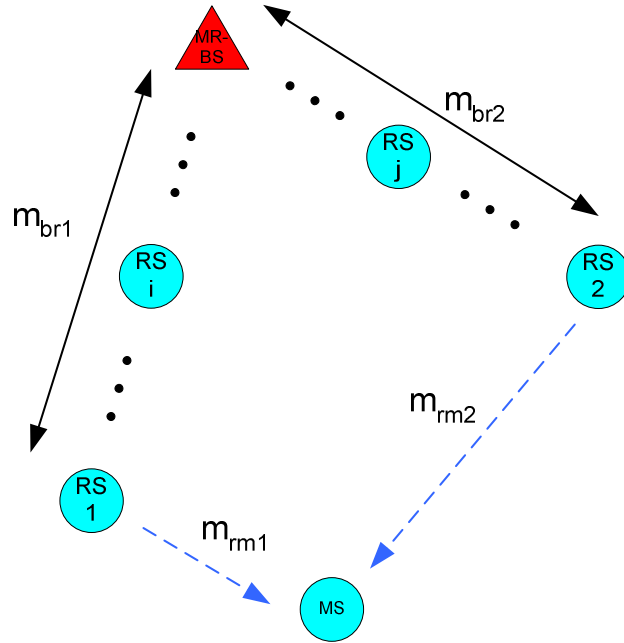

Figure 1. MS route determination in Scenario 1.

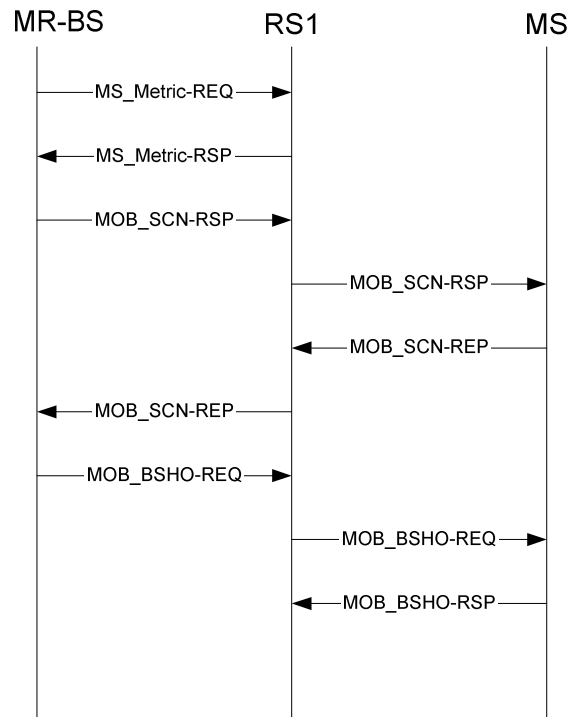

Figure 2. Signaling diagram for Scenario 1

## Routing solution for Scenario 2

Routing problem for Scenario 2 is shown in Figure 3. It is assumed that MS has detected a stronger preamble from BS and has set-up legacy 802.16e UL and DL communication links directly with the BS. Based on CQI feedback from the MS, the MR-BS computes the routing metric for the UL link, denoted as  $m_{mb}$  in Figure 3. Furthermore, RS1 has successfully set-up communication path with the MR-BS and  $m_{br1}$  is known at the MR-BS through the RS metric reporting procedure described above.

With respect to UL communication, MS selection of the MR-BS as the network attachment point maybe suboptimum, since the UL route via RS1 may result in a better ETE metric. To evaluate the ETE metric for this route, knowledge of the link metric for the MS-to-RS1 link,  $m_{mr1}$ , is required at the MR-BS.

The following procedure is proposed for obtaining  $m_{mr1}$  at the MR-BS. Note that the MR-BS maintains an active UL communication link with the MS and hence performs scheduling of all UL bursts from the MS. The MR-BS informs RS1 of the allocation for an impending UL burst from the MS. RS1 proceeds to receive the UL burst from the MS and performs UL CQI measurements, which are reported to the MR-BS in the MS-Metric-RSP message. The MR-BS derives  $m_{mr1}$  based on the CQI provided. The MS-Metric-RSP message can be sent to the MR-BS in an unsolicited fashion or in response to the MS-Metric-REQ message.

RS1 is informed of the MS UL burst allocation in the MS\_UL\_Allocation-REP message. The format of this message depends on the functionality of RS1. If RS1 is deployed as a transparent RS, it reads the legacy DL and UL maps transmitted in the access interval by the MR-BS. In this case, it is sufficient to specify in the MS\_UL\_Allocation-REP message a CID of the MS UL burst to be received by RS1. RS1 can learn of the burst allocation by reading the UL map. In the second case, RS1 is deployed as a non-transparent RS. In this case, RS1 cannot hear the legacy UL map, and the MS\_UL\_Allocation-REP message must specify the exact UL slot allocation for the MS burst. The steps of this process are illustrated in Figure 4. Upon obtaining  $m_{mr1}$  and  $m_{br1}$ , the MR-BS computes the ETE metric for the MS-to-MR-BS via RS1. The details of this computation are not specified in the standard. If deemed necessary, the MR-BS may assign RS1 to relay UL bursts from the MS or it may initiate MS handover procedure from MR-BS to RS1.

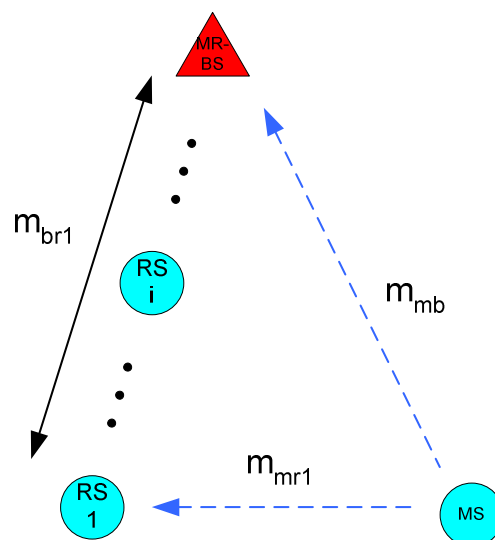

Figure 3. MS route determination in Scenario 2

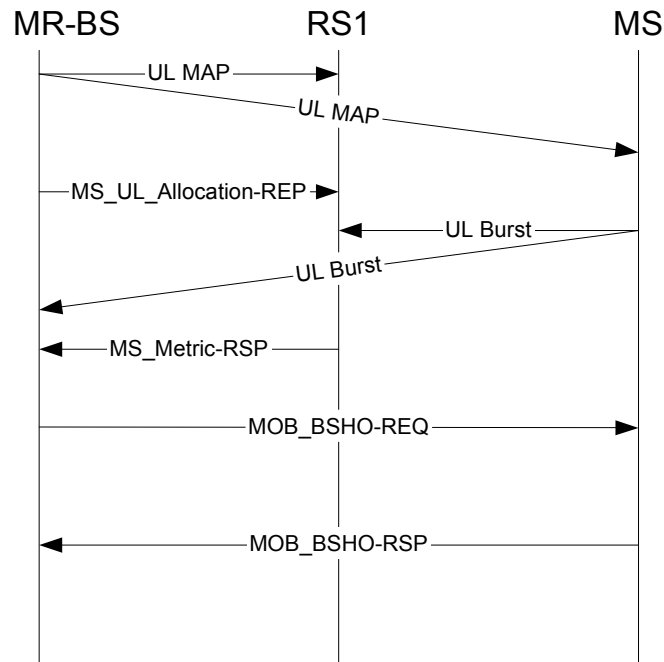

Figure 4. Bounce diagram for Scenario 2

### Proposed text changes

[Insert the following text into section 6.3.25]

Computation at the MR-BS of the end-to-end (ETE) routing metric for the multihop path between the MR-BS and an MS in its cell shall be enabled. The multihop path between the MR-BS and an MS can be decomposed into two path segments. The first path segment is the multihop path between the MR-BS and the access RS of the MS. The second path segment is the access link between the MS and the access RS. To enable ETE routing metric computation, routing metrics for each path segment shall be reported to the MR-BS. The routing metric for the path segment between MR-BS and access RS shall be reported to the MR-BS in the RS\_Metric-REP message. Optionally, CQI for a link between an RS originating the message and a neighbor RS may be reported in the RS\_Metric-REP message.

The channel quality metric for the path segment consisting of the access link between the access RS and the MS shall be reported in the MS\_Metric-RSP message. The access RS shall send the MS\_Metric-RSP message to the MR-BS in response to the MS\_Metric-REQ message or by sending an unsolicited MS\_Metric-RSP message.

To enable access link quality measurements on the uplink, the access RS shall be capable of processing the MS\_UL\_Allocation-REP message received from the MR-BS and performing the required link measurements on the burst allocation specified in the MS\_UL\_Allocation-REP message.

The MR-BS shall be capable of selecting the route between itself and the MS based on the ETE routing metrics for the multihop paths between the MR-BS and the MS. The UL and DL routes may optionally be different for the same MS.

[Insert new section 6.2.3.AA]

#### Section 6.3.2.3.AA RS\_Metric-REP

This message shall be sent by the RS to the MR-BS in order to inform MR-BS of its ETE routing metric or inform MR-BS of a CQI for a link to a neighbor RS. The message shall be sent on the RS basic CID.

Syntax	Size	Notes
RS_Metric-REP Message Format() {		
Management Message Type=TBD	8 bits	
Node ID	48 bits	ID of the RS reporting the metric
Reporting mode	1 bit	0: ETE metric 1: Link CQI
If (Reporting mode == 0) {		
ETE Metric	16 bits	The metric of the path from the access station to its MR-BS
Metric Identifier	32 bits	Identifies the ETE metric being used. Most significant 3 octets represent the OUI. Least significant 1 octet represents specific metric. See table (below) for metric identifier encoding.
Number of Hops	8 bits	Number of hops from the access station to its MR-BS
}		
If (Reporting mode == 1) {		
N_NBR	8 bits	Number of "RS ambles" reported on
CQI Report mode	1 bits	0: RSSI 1: CINR

For (i=0, i< N_NBR, i++){		
RS amble index	8 bits	Index of the detected RS amble
If (CQI Report mode == 0)		
RSSI mean	8 bits	
If (CQI Report mode == 1)		
CINR mean	8 bits	
}		
}		
Padding	Variable	Shall be set to zero
}		

[Insert new section 6.3.2.3.AB]

#### Section 6.3.2.3.AB MS\_Metric-REQ

This message shall be sent from the MR-BS to the access RS in order to request the MS\_Metric-RSP message from the access RS. This message is sent on the access RS basic CID. The message specifies the CID of the MS for which the MS\_Metric-RSP message is requested.

Syntax	Size	Notes
MS_Metric-REQ() {		
Management Message Type=TBD	8 bits	
CID	16 bits	CID of the MS
Report mode	1 bit	Specifies DL or UL measurements 0: DL report requested 1: UL report requested
Report mode	2 bits	00: RSSI 10: CINR



		01: ETE Metric 11: reserved
Padding	6 bits	Shall be set to zero
}		

[Insert new section 6.3.2.3.AC]

### Section 6.3.2.3.AC MS\_Metric-RSP

This message is used to report UL or DL access link CQI to the MR-BS. This message is sent on the access RS basic CID. The message specifies the basic CID of the MS for which the metric is reported.

Syntax	Size	Notes
MS_Metric-REP() {		
Management Message Type=TBD	8 bits	
CID	16 bits	CID of the MS
Report mode	1 bit	Specifies DL or UL measurements 0: DL report 1: UL report
CQI Report mode	1 bits	0: RSSI 1: CINR
If (Report mode == 00)		
RSSI mean	8 bits	
If (Report mode == 10)		
CINR mean	8 bits	
If (Report mode == 01)		
ETE Metric	16 bits	

Padding	6 bits	Shall be set to zero
}		

[Insert new section 6.3.2.3.AD]

#### Section 6.3.2.3.AD MS\_UL\_Allocation-REP

This message is used to report MS UL burst allocations to an RS to enable UL link quality measurements on the MS-to-RS link. This message shall be sent from the MR-BS to an RS on the access RS basic CID. The message specifies the CID of the MS for which the UL metric is to be reported.

Syntax	Size	Notes
MS_UL_allocation-REP {		
Management Message Type=TBD	8 bits	
CID	16 bits	CID of the MS
Allocation_report_mode	1 bit	0: Explicit allocation report mode 1: CID-based allocation report mode
if (Allocation_report_mode == 0) {		
UIUC	4 bits	
OFDMA symbol offset	7 bits	
Length	4 bits	Length of the MS uplink zone
Permutation	2 bits	
PUSC UL_IDcell	7 bits	
First slot in zone	10 bits	First slot of the allocation for the MS
Length	10 bits	Length of the allocation for the MS
}		
if (Allocation_report_mode == 1) {		
CID	16 bits	CID of the burst to be received

}		
Padding	Variable	
}		