

Project	IEEE 802.16 Broadband Wireless Access Working Group < http://ieee802.org/16 >	
Title	A Proposal for Relay MAC PDU Format in 16j network	
Date Submitted	2007-03-06	
Source(s)	Qu Hongyun, Sean Cai, Mary Chion, Liu Yang, Chen Yuqin ZTE Corporation 712/2, Liantang Pengji Industrial Park, Luohu District, Shenzhen, P.R.China 518004	Voice:+86-755-26773000 exd. 6614 E-mail: qu.hongyun@zte.com.cn , scai@zteusa.com
Re:	IEEE 802.16j-07/007r2:“Call for Technical comments and contributions regarding IEEE Project P802.16j”	
Abstract	This document presents a relay MAC PDU format for IEEE 802.16j.	
Purpose	Propose the sleep mode operations for IEEE 802.16j	
Notice	This document has been prepared to assist IEEE 802.16. It is offered as a basis for discussion and is not binding on the contributing individual(s) or organization(s). The material in this document is subject to change in form and content after further study. The contributor(s) reserve(s) the right to add, amend or withdraw material contained herein.	
Release	The contributor grants a free, irrevocable license to the IEEE to incorporate material contained in this contribution, and any modifications thereof, in the creation of an IEEE Standards publication; to copyright in the IEEE's name any IEEE Standards publication even though it may include portions of this contribution; and at the IEEE's sole discretion to permit others to reproduce in whole or in part the resulting IEEE Standards publication. The contributor also acknowledges and accepts that this contribution may be made public by IEEE 802.16.	
Patent Policy and Procedures	The contributor is familiar with the IEEE 802.16 Patent Policy and Procedures < http://ieee802.org/16/ipr/patents/policy.html >, including the statement "IEEE standards may include the known use of patent(s), including patent applications, provided the IEEE receives assurance from the patent holder or applicant with respect to patents essential for compliance with both mandatory and optional portions of the standard." Early disclosure to the Working Group of patent information that might be relevant to the standard is essential to reduce the possibility for delays in the development process and increase the likelihood that the draft publication will be approved for publication. Please notify the Chair < mailto:chair@wirelessman.org > as early as possible, in written or electronic form, if patented technology (or technology under patent application) might be incorporated into a draft standard being developed within the IEEE 802.16 Working Group. The Chair will disclose this notification via the IEEE 802.16 web site < http://ieee802.org/16/ipr/patents/notices >.	

A Proposal for Relay MAC PDU Format in 16j Network

Introduction

As described in current 16j baseline, relay MAC PDU can be transmitted by using the tunnel or station ID. Here we propose a relay MAC PDU format which is transmitted on relay link. The relay MAC PDU format proposed here is used for multihop relay network without using the tunnel.

A multihop relay network is illustrated as Figure 1. MR-BS receives PDUs from the network for mobile stations. MR-BS shall create relay MAC PDUs (R-PDUs) for transmission on relay link to the designated RS by encapsulating MS's MAC PDUs to a relay MAC PDU (R-PDU). RS receives the relay MAC PDU and decodes it to regular MAC PDU for its MS.

For multihop relay network, MR-BS encapsulates subordinate R-PDU and MS MAC PDU into a superordinate R-PDU. MR-BS always first create R-PDUs for RS of the last hop and encapsulates the created R-PDU and MS MAC PDUs, if exist and necessary, into a superordinate R-PDU. The above process is repeated until the R-PDU for the RS of the first hop is created. RS of the first hop receives and decodes the R-PDU into regular MS MAC PDUs and R-PDUs, and transmits them to MS and its subordinate RS on access link and relay link respectively.

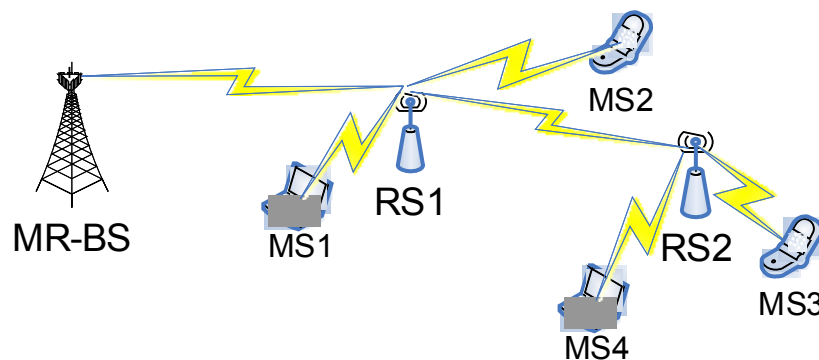

Figure 1

The exemplary format of relay MAC PDU (R-PDU) is illustrated in Figure 2. The R-PDU for RS1 is created by MR-BS and transmitted on relay link to RS1. After RS1 receives this R-PDU, RS1 decodes the R-PDU to R-PDU for RS2 and MAC PDUs for MS1 and MS2. RS1 transmits MAC PDUs for MS on access link and transmits R-PDU to RS2 on relay link. CRC fields can be included in R-PDUs. The PHY burst allocation on which R-PDU is transmitted is addressed to the designated RS which is respected to receive the R-PDU.

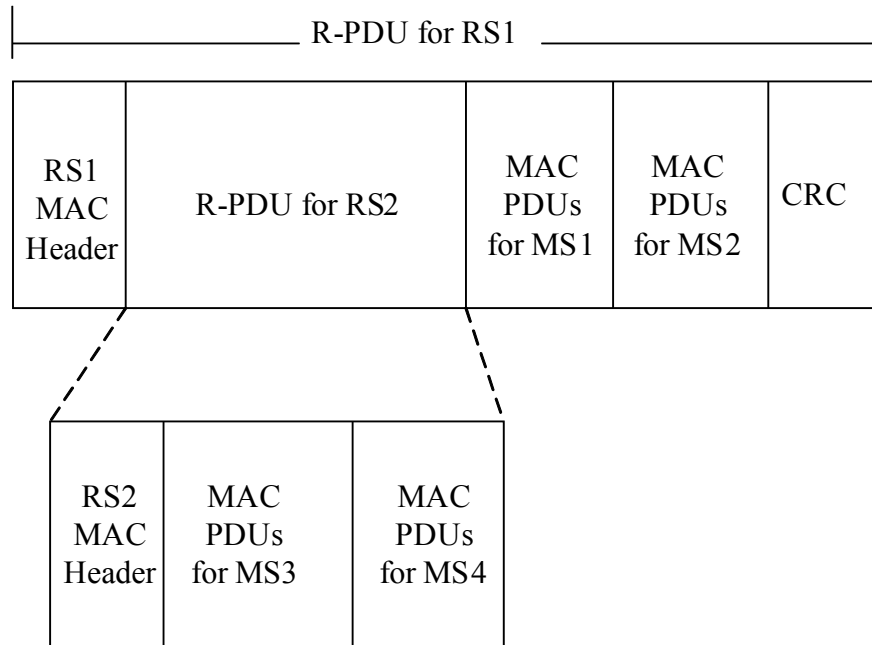

Figure 2

Specific Text change

[Insert the following sentence at the end of the section 6.3.3.8.2]

MR-BS creates a relay MAC PDU (R-PDU) by encapsulating MS MAC PDUs and/or subordinate R-PDUs which are transmitted to the same designated RS. The PHY burst on which R-PDUs are transmitted is addressed to the designated RS.

RS receives and decodes the R-PDUs into MS MAC PDU and/or subordinate R-PDU. RS transmits MS MAC PDU on access link to its MS. RS transmits subordinate R-PDU on relay link to its subordinate RS.

References

[1] IEEE802.16j-06/026r2 Baseline Document for Draft Standard for 16j