

Bandwidth Request for Distributed Systems

IEEE 802.16 Presentation Submission Template (Rev. 8.3)

Document Number:

IEEE S802.16j-07/148

Date Submitted:

2007-01-16

Source:

Masato Okuda, Yuefeng Zhou
Fujitsu

Voice: +81-44-754-2811
okuda@jp.fujitsu.com

[Add co-authors]

Venue:

IEEE 802.16 Session #47, London, UK

Base Document:

IEEE C802.16j-07/148

Purpose:

For discussion and approval of inclusion of the proposed text into the P802.16j baseline document.

Notice:

This document has been prepared to assist IEEE 802.16. It is offered as a basis for discussion and is not binding on the contributing individual(s) or organization(s). The material in this document is subject to change in form and content after further study. The contributor(s) reserve(s) the right to add, amend or withdraw material contained herein.

Release:

The contributor grants a free, irrevocable license to the IEEE to incorporate material contained in this contribution, and any modifications thereof, in the creation of an IEEE Standards publication; to copyright in the IEEE's name any IEEE Standards publication even though it may include portions of this contribution; and at the IEEE's sole discretion to permit others to reproduce in whole or in part the resulting IEEE Standards publication. The contributor also acknowledges and accepts that this contribution may be made public by IEEE 802.16.

IEEE 802.16 Patent Policy:

The contributor is familiar with the IEEE 802.16 Patent Policy and Procedures <<http://ieee802.org/16/ipr/patents/policy.html>>, including the statement "IEEE standards may include the known use of patent(s), including patent applications, provided the IEEE receives assurance from the patent holder or applicant with respect to patents essential for compliance with both mandatory and optional portions of the standard." Early disclosure to the Working Group of patent information that might be relevant to the standard is essential to reduce the possibility for delays in the development process and increase the likelihood that the draft publication will be approved for publication. Please notify the Chair <<mailto:chair@wirelessman.org>> as early as possible, in written or electronic form, if patented technology (or technology under patent application) might be incorporated into a draft standard being developed within the IEEE 802.16 Working Group. The Chair will disclose this notification via the IEEE 802.16 web site <<http://ieee802.org/16/ipr/patents/notices>>.

Introduction

- In distributed scheduling systems, RS is required to start to request BW on R-UL after receiving BW request code from MS in order to minimize latency.

- .

Introduction

- In distributed scheduling systems, RS is required to start to request BW on R-UL after receiving BW request code from MS in order to minimize latency.

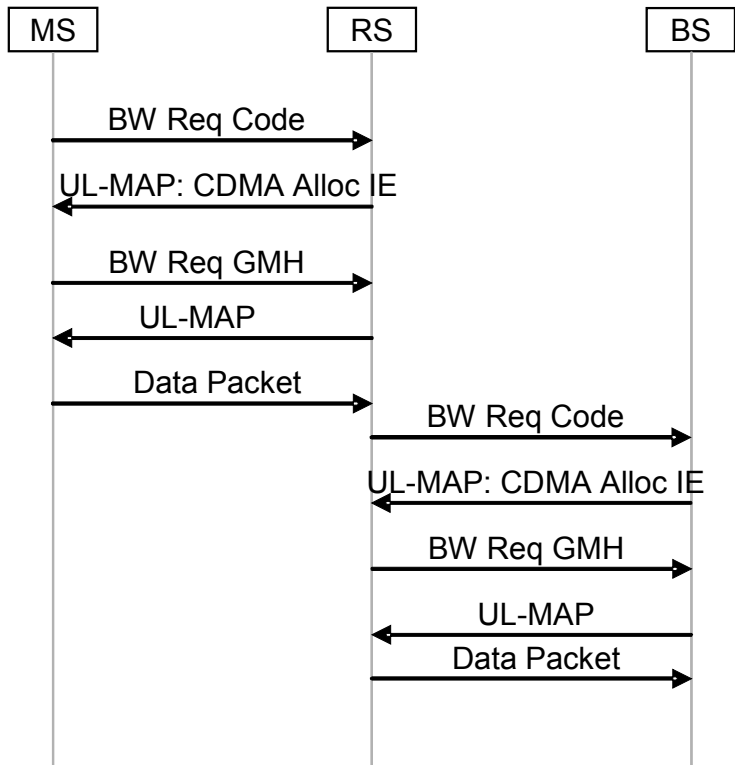

RS Starts BW request after receiving PDUs

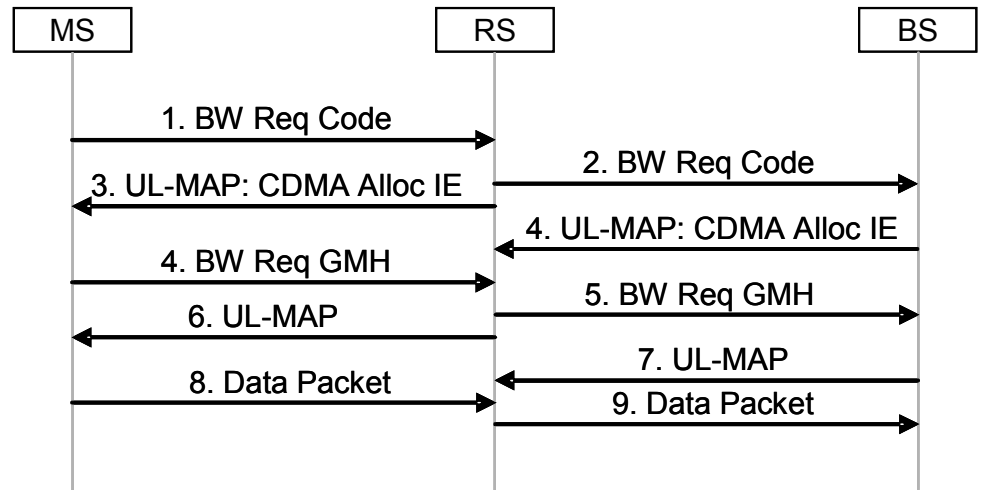

RS Starts BW request after receiving BW Req code

Problem

- Since BW allocations on access and relay links are done individually by the RS and the MR-BS in distributed model, the BW on the R-UL could be assigned before the RS receives PDUs from the MS.

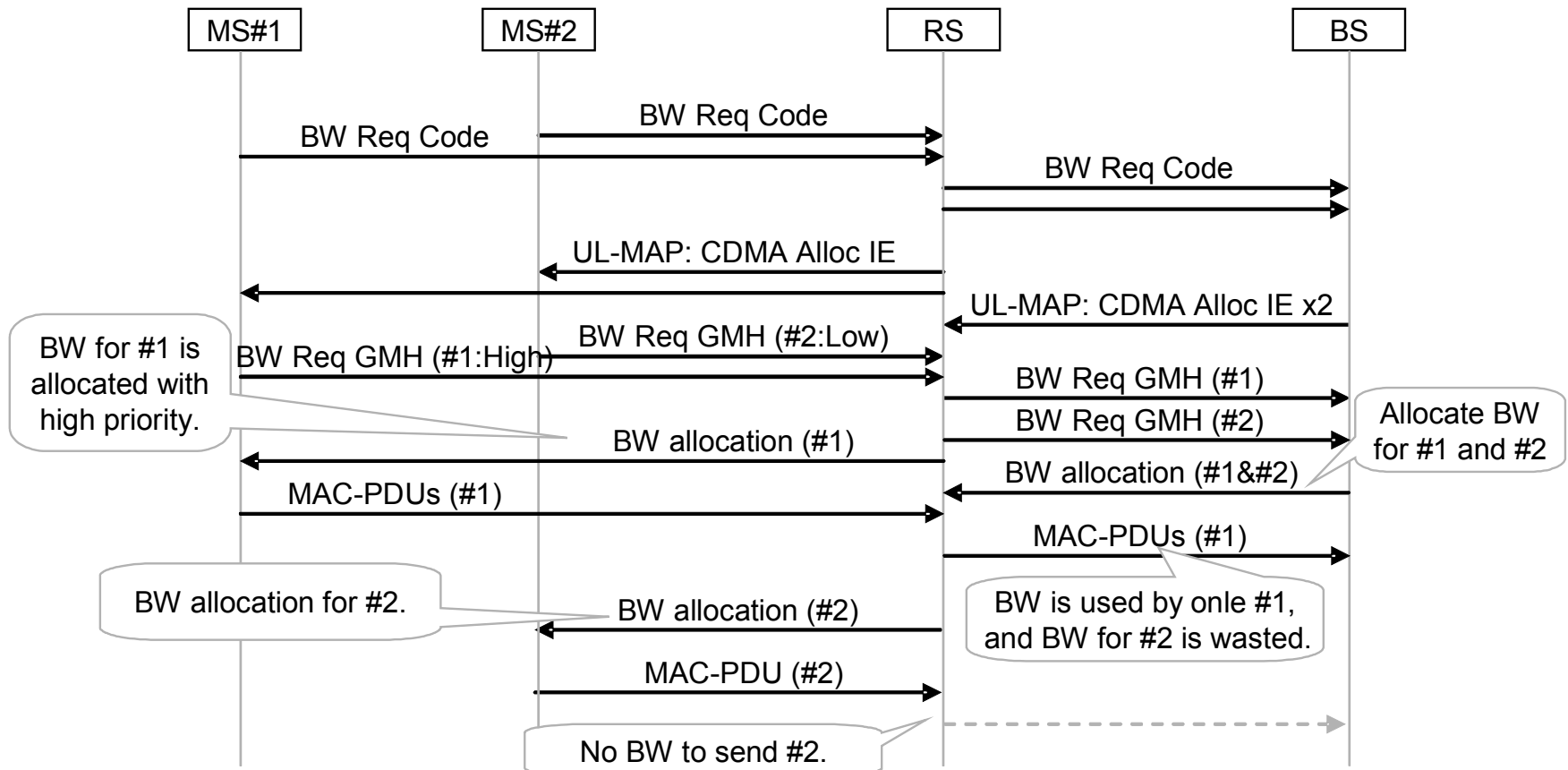

Proposed Scheme

- To prevent the timing misalignment, the RS inserts timing information in the BW request header that it transmits to its upstream MR-BS or RS. This timing information informs the MR-BS of when it expects to need the relay uplink allocation.

