

Project	<b>IEEE 802.16 Broadband Wireless Access Working Group</b> < <a href="http://ieee802.org/16">http://ieee802.org/16</a> >	
Title	<b>Comment contribution</b>	
Date Submitted	2002-03-06	
Source(s)	Dave Beyer	<a href="#">Nokia Wireless Routers</a>
	Carl Eklund	<a href="#">Nokia Research Center</a>
	Mika Kasslin	<a href="#">Nokia Research Center</a>
	Nico van Waes	<a href="#">Nokia Wireless Routers</a>
Re:	Ballot 4a	
Abstract	Text corresponding to submitted comments on P802.16a/D2	
Purpose	Consideration & decision	
Notice	This document has been prepared to assist IEEE 802.16. It is offered as a basis for discussion and is not binding on the contributing individual(s) or organization(s). The material in this document is subject to change in form and content after further study. The contributor(s) reserve(s) the right to add, amend or withdraw material contained herein.	
Release	The contributor grants a free, irrevocable license to the IEEE to incorporate text contained in this contribution, and any modifications thereof, in the creation of an IEEE Standards publication; to copyright in the IEEE's name any IEEE Standards publication even though it may include portions of this contribution; and at the IEEE's sole discretion to permit others to reproduce in whole or in part the resulting IEEE Standards publication. The contributor also acknowledges and accepts that this contribution may be made public by IEEE 802.16.	
Patent Policy and Procedures	The contributor is familiar with the IEEE 802.16 Patent Policy and Procedures (Version 1.0) < <a href="http://ieee802.org/16/ipr/patents/policy.html">http://ieee802.org/16/ipr/patents/policy.html</a> >, including the statement "IEEE standards may include the known use of patent(s), including patent applications, if there is technical justification in the opinion of the standards-developing committee and provided the IEEE receives assurance from the patent holder that it will license applicants under reasonable terms and conditions for the purpose of implementing the standard."	
	<p>Early disclosure to the Working Group of patent information that might be relevant to the standard is essential to reduce the possibility for delays in the development process and increase the likelihood that the draft publication will be approved for publication. Please notify the Chair &lt;<a href="mailto:r.b.marks@ieee.org">mailto:r.b.marks@ieee.org</a>&gt; as early as possible, in written or electronic form, of any patents (granted or under application) that may cover technology that is under consideration by or has been approved by IEEE 802.16. The Chair will disclose this notification via the IEEE 802.16 web site</p> <p>&lt;<a href="http://ieee802.org/16/ipr/patents/notices">http://ieee802.org/16/ipr/patents/notices</a>&gt;.</p>	

## Mesh Overview changes

*page 22, line 1 through 30 replace with the following:*

### 6. MAC Sublayer - Common Part

*Change the first paragraph of this clause to the following:*

A network that utilizes a shared medium must provide an efficient sharing mechanism. Two-way point-to-multipoint and mesh topology wireless networks are good examples of shared media: here the media are the space through which the radio waves propagate.

*Insert clause heading at the end of the first paragraph of this clause.*

#### 6.1 Point-to-multipoint

*Insert at end of clause the new clause 6.2 as follows:*

#### 6.2 Mesh

In the optional mesh mode, the main difference as compared to the PMP mode described above, is that the channel resources (e.g. the ability to transmit) is shared between the systems on demand basis. Depending on the transmission protocol algorithm used, this can be done on basis of equality using distributed scheduling, or on the basis of superiority of the systems closer to the mesh BS, which effectively results in centralized scheduling, or on a combination of both.

Within a mesh network, a system that has a direct connection to backhaul services outside the mesh network, is termed a mesh BS. All the other systems of a mesh network are termed mesh SS. In general, the systems of a mesh network are termed nodes. Within mesh context, upstream and downstream are defined as traffic in the direction of the mesh BS and traffic away from the mesh BS respectively.

The other three important terms of mesh systems are neighbor, neighborhood and extended neighborhood. The stations with which a node has direct links are called neighbors. Neighbors of a node shall form a neighborhood. A node's neighbors are considered to be "one hop" away from the node. An extended neighborhood contains, additionally, all the neighbors of the neighborhood.

In a mesh system not even the mesh BS can transmit without having to coordinate with other nodes. With distributed scheduling all the nodes including the mesh BS shall coordinate their transmissions in their two-hop neighborhood. All the nodes broadcast their schedules (available resources, requests and grants) to all their neighbors. Optionally the schedule may also be established by directed requests and grants between two nodes. There is no difference in the mechanism used in determining the schedule for downstream and upstream. Nodes shall just ensure that the resulting transmissions do not cause collisions with the data and control traffic scheduled.

In the other mode of operation with centralized scheduling resources are granted in a more centralized manner. The mesh BS shall gather resource requests from all the mesh SSs within a certain hop range. It shall determine amount of granted resources for each link in the network both in downstream and upstream, and communicates these grants to all the mesh SSs within the hop range. The grant messages do not contain the actual schedule but each node shall compute it by using the predetermined algorithm with given parameters.

1 The mesh MAC is connectionless. All the communications are in the context of a link, which is established  
2 between two nodes. One link shall be used for all the data transmissions between the two nodes. QoS is pro-  
3 visioned over links on message by message basis. No service or QoS parameters are associated to a link but  
4 each unicast message has service paramters in the header. Traffic classification and flow regulation are per-  
5 formed at ingress node by upper-layer classification/regulation protocol. The service parameters associated  
6 to each message shall be communicated together with the message content via the MAC SAP.  
7  
8

9  
10 Mesh systems typically use omnidirectional or 360 degree steerable antennae, but can also be co-located  
11 using sector antennas. At the edge of the coverage area of the mesh network, where forwarding to systems  
12 more hops away from the mesh BS is no longer required, even highly directional antennae can be used.  
13  
14  
15  
16  
17  
18  
19  
20  
21  
22  
23  
24  
25  
26  
27  
28  
29  
30  
31  
32  
33  
34  
35  
36  
37  
38  
39  
40  
41  
42  
43  
44  
45  
46  
47  
48  
49  
50  
51  
52  
53  
54  
55  
56  
57  
58  
59  
60  
61  
62  
63  
64  
65

## Mesh SAP changes

*page 22, line 31 add the following:*

*Change 6.1 heading as follows:*

### 6.3 MAC service definition for PMP

*Replace the first sentence of the first paragraph in the clause with the following:*

This subclause defines services between the MAC and the Convergence Sublayers in PMP mode.

*Insert clause 6.4 and its subclauses:*

### 6.4 MAC service definition for mesh

This subclause defines services between the MAC and the Convergence Sublayers in mesh mode. This is a logical interface. As such, the primitives described are informative. Their purpose is to describe the information that must necessarily be exchanged between the MAC and the CLs to enable each to perform its requirements as specified in the remainder of this document. This subclause does not impose message formats or state machines for the use of these primitives.

In a layered protocol system, the information flow across the boundaries between the layers can be defined in terms of primitives that represent different items of information and cause actions to take place. These primitives do not appear as such on the medium (the air interface) but serve to define more clearly the relations of the different layers. The semantics are expressed in the parameters that are conveyed with the primitives.

#### 6.4.1 Primitives

The IEEE 802.16 MAC supports the following primitives at the MAC Service Access Point in mesh mode:

```

MAC_CREATE_CONNECTION.indication
MAC_CHANGE_CONNECTION.indication
MAC_TERMINATE_CONNECTION.request
MAC_TERMINATE_CONNECTION.indication
MAC_DATA.request
MAC_DATA.indication
MAC_FORWARDING_UPDATE.request
MAC_FORWARDING_UPDATE.indication

```

In mesh mode none of the actions cause the initiating CS to send a REQUEST primitive to its MAC sublayer. They are either indications of the results from the processes handled by the MAC CPS management entity, or data delivery actions needed to convey information to the peer CS.

### 6.4.1.1 MAC\_CREATE\_CONNECTION.indication

#### 6.4.1.1.1 Function

This primitive is issued by a MAC entity to the CS, to report a new link established to a neighbor node.

#### 6.4.1.1.2 Semantics of the service primitive

The parameters of the primitive are as follows:

```
MAC_CREATE_CONNECTION.indication
{
  CID
  max length,
  service flow parameters,
  encryption flag
}
```

The CID is the Connection ID in Mesh as conveyed in the Generic MAC header.

The max length parameter specifies the maximum length of SDUs that are allowed over the link.

The service flow parameters include information on

```
Target data rate for the link in Mbps
Transmit energy for the link
Estimate of packet error rate for 256-byte packets
```

The encryption flag specifies that the data carried over this link is encrypted, if ON, If OFF, then no encryption is used.

#### 6.4.1.1.3 When generated

This primitive is generated whenever a new link has been established to a neighbor node.

#### 6.4.1.1.4 Effect of receipt

The receipt of the primitive is an indication to the CS that a link to the given neighbor node is up and can be used for data delivery.

### 6.4.1.2 MAC\_CHANGE\_CONNECTION.indication

#### 6.4.1.2.1 Function

This primitive is issued by a MAC entity to the CS, to report new parameters of an existing link to a neighbor node.

#### 6.4.1.2.2 Semantics of the service primitive

The parameters of the primitive are as follows:

```
MAC_CHANGE_CONNECTION.indication
{
  CID,
```

```

1         max length,
2         service parameters,
3         encryption flag
4     }
5
6

```

7 The CID is the Connection ID in Mesh as conveyed in the Generic MAC header.

8  
9 The max length parameter specifies the maximum length of SDUs that are allowed over the link.

10  
11 The service parameters include information on

```

12
13
14     Target data rate for the link in Mbps
15     Transmit energy for the link
16     Estimate of packet error rate for 256-byte packets
17
18

```

19 The encryption flag specifies that over this link encryption is possible, if ON, If OFF, then no encryption is possible.

#### 20 21 22 **6.4.1.2.3 When generated**

23  
24 This primitive is generated whenever parameters of an existing link has changed.

#### 25 26 27 **6.4.1.2.4 Effect of receipt**

28  
29 The CS shall take into account new link parameters in the use of the link.

### 30 31 32 **6.4.1.3 MAC\_TERMINATE\_CONNECTION.request**

#### 33 34 35 **6.4.1.3.1 Function**

36  
37 This primitive is issued by a CS, to terminate an existing link to a neighbor node.

#### 38 39 40 **6.4.1.3.2 Semantics of the service primitive**

41  
42 The parameters of the primitive are as follows:

```

43
44     MAC_TERMINATE_CONNECTION.indication
45     {
46         CID
47     }
48
49

```

50 The CID is the Connection ID in Mesh as conveyed in the Generic MAC header.

#### 51 52 53 **6.4.1.3.3 When generated**

54  
55 This primitive is generated to bring down an existing link to a neighbor node.

#### 56 57 58 **6.4.1.3.4 Effect of receipt**

59  
60 The receipt of the primitive causes the MAC to terminate the connection and report that to the MAC entity in the neighbor the link was to.

#### 6.4.1.4 MAC\_TERMINATE\_CONNECTION.indication

##### 6.4.1.4.1 Function

This primitive is issued by the MAC entity of the non-initiating side to indicate termination of the link to a neighbor node.

##### 6.4.1.4.2 Semantics of the service primitive

The parameters of the primitive are as follows:

```
MAC_TERMINATE_CONNECTION.indication
{
    CID,
}
```

The CID is the Connection ID in Mesh as conveyed in the Generic MAC header.

##### 6.4.1.4.3 When generated

This primitive is generated by the MAC sublayer when it receives an indication in a MSH-NCFG message.

##### 6.4.1.4.4 Effect of receipt

The receipt of the primitive is an indication to the CS that the link to the given neighbor node is down and cannot be used for data delivery.

#### 6.4.1.5 MAC\_DATA.request

##### 6.4.1.5.1 Function

This primitive defines the transfer of data to the MAC entity from a convergence sublayer service access point.

##### 6.4.1.5.2 Semantics of the service primitive

The parameters of the primitive are as follows:

```
MAC_DATA.request
{
    CID,
    length,
    data,
    encryption flag
}
```

The CID is the Connection ID in Mesh as conveyed in the Generic MAC header.

The length parameter specifies the length of the MAC SDU in bytes.

The data parameter specifies the MAC SDU as received by the local MAC entity.

The priority/class parameter specifies the priority class of the MAC SDU.

1 The reliability parameter specifies maximum number of transmission attempts at each link.

2  
3 The drop precedence parameter indicates relative MSDU dropping likelihood.

4  
5 The encryption flag specifies that the data sent over this link is to be encrypted, if ON. If OFF, then no  
6 encryption is used.  
7

#### 8 9 **6.4.1.5.3 When generated**

10  
11 This primitive is generated by a convergence sublayer whenever an MAC SDU is to be transferred to a peer  
12 entity.  
13

#### 14 15 **6.4.1.5.4 Effect of receipt**

16  
17 The receipt of the primitive causes the MAC entity to process the MAC SDU through the MAC sublayer and  
18 pass the appropriately formatted PDUs to the PHY transmission convergence sublayer for transfer to peer  
19 MAC sublayer entity, using the Node ID specified.  
20  
21

#### 22 23 **6.4.1.6 MAC\_DATA.indication**

##### 24 25 **6.4.1.6.1 Function**

26  
27 This primitive defines the transfer of data from the MAC to the convergence sublayer.  
28

##### 29 30 **6.4.1.6.2 Semantics of the service primitive**

31  
32 The parameters of the primitive are as follows:  
33

```
34     MAC_DATA.request
35     {
36         CID
37         length,
38         data,
39         reception status,
40         encryption flag
41     }
42  
43  
44
```

45 The CID is the Connection ID in Mesh as conveyed in the Generic MAC header.  
46

47 The length parameter specifies the length of the MAC SDU in bytes.  
48

49 The data parameter specifies the MAC SDU as received by the local MAC entity.  
50

51 The reception status parameter indicates transmission success or failure for those PDUs received via the  
52 MAC\_DATA.indication.  
53  
54

##### 55 56 **6.4.1.6.3 When generated**

57  
58 This primitive is generated whenever an MAC SDU is to be transferred to a peer convergence entity.  
59  
60

##### 61 62 **6.4.1.6.4 Effect of receipt**

63 The effect of receipt of this primitive by a convergence entity is dependent on the validity and content of the  
64 MAC SDU.  
65



### 6.4.1.7 MAC\_FORWARDING\_UPDATE.request

#### 6.4.1.7.1 Function

This primitive defines the transfer of the centralized scheduling configuration to the MAC entity from a convergence sublayer service access point in the mesh BS.

#### 6.4.1.7.2 Semantics of the service primitive

The parameters of the primitive are as follows:

```
MAC_FORWARDING_UPDATE.request
{
    number of nodes,
    node parameters[number of nodes]
}
```

The number of nodes parameter indicates number of nodes in the scheduling tree of this mesh BS.

The node parameters entry shall contain the following information:

Node ID: The Node ID parameter indicates the node.  
 number of children: The number of nodes parameter indicates number of children the given node .  
 child parameters[number of children]

Each child parameters entry shall contain the following information:

child index: The child index indicates index into the list of Node IDs  
 upstream burst profile: The upstream burst profile indicates burst profile of link to child node  
 downstream burst profile: The downstream burst profile indicates burst profile of link from child node

#### 6.4.1.7.3 When generated

This primitive is generated in the mesh BS whenever it has changed the schedule tree.

#### 6.4.1.7.4 Effect of receipt

The receipt of this primitive causes the MAC to generate a MSH-CSCF message with the given information. The message shall be distributed to all the nodes listed in the tree.

### 6.4.1.8 MAC\_FORWARDING\_UPDATE.indication

#### 6.4.1.8.1 Function

This primitive defines the transfer of the centralized scheduling configuration from the MAC to the convergence sublayer.

#### 6.4.1.8.2 Semantics of the service primitive

The parameters of the primitive are as follows:

```
MAC_FORWARDING_UPDATE.indication
{
```

```

1         Node ID self
2         number of nodes,
3         node parameters[number of nodes]
4     }
5
6

```

7 The Node ID self indicates the Node ID of the node itself.

8  
9 The number of nodes parameter indicates number of nodes in the scheduling tree of this mesh BS.

10  
11 The node parameters entry shall contain the following information:

12  
13  
14 Node ID: The Node ID parameter indicates the node.  
15 number of children: The number of nodes parameter indicates number of children the given node .  
16 child parameters[number of children]

17  
18  
19 Each child parameters entry shall containing the following information:

20  
21 child index: The child index indicates index into the list of Node IDs  
22 upstream burst profile: The upstream burst profile indicates burst profile of link to child node  
23 downstream burst profile: The downstream burst profile indicates burst profile of link from child  
24 node  
25

#### 26 27 **6.4.1.8.3 When generated**

28  
29  
30 This primitive is generated by the MAC sublayer at all the nodes, which have received the MSH-CSCF mes-  
31 sage, when new centralized schedule with revised schedule tree takes effect.

#### 32 33 **6.4.1.8.4 Effect of receipt**

34  
35 The receipt of this primitive synchronizes the forwarder and MAC scheduler to routing changes.

36  
37  
38 | *page 23, line 28*

#### 39 40 **6.4.1.8.5 CID in Mesh**

41  
42  
43 The Connection ID in mesh mode is specified as shown in Table 1 to convey broadcast/unicast, service  
44 parameters and the link identification.  
45  
46  
47  
48  
49  
50  
51  
52  
53  
54  
55  
56  
57  
58  
59  
60  
61  
62  
63  
64  
65

Table 1—Mesh CID construction

Syntax	Size	Notes
CID {		
if (Xmt Link ID == 0xFF) {		
<b>Logical Network ID</b>	8 bits	0x00: All-net Broadcast
} else {		
<b>Type</b>	2 bits	0x0 MAC Management 0x1 IP 0x2-0x3 Reserved
<b>Reliability</b>	1 bit	0x0 No retransmissions 0x1 Up to 4 retransmissions
<b>Priority/Class</b>	3 bits	
<b>Drop Precedence</b>	2 bits	
}		
<b>Xmt Link ID</b>	8 bits	0xFF: MAC management broadcast
}		

**Priority/Class**

Priority field indicates message class.

**Drop Precedence**

Messages with larger Drop Precedence must have higher dropping likelihood during congestion.

**Xmt Link ID**

The Link ID assigned by the transmitter node to the link to the receiver node.

**Page 36, line 32 replace with following**

**Xmt Link ID** 8 bits

**Replace content of 6.2.2.4 with the following:**

1 The mesh subheader, which always follows the generic MAC header as specified in 6.2.2.1.1 is specified as  
2 shown in Table 2.  
3  
4

5  
6 **Table 2—Mesh subheader format**  
7

Syntax	Size	Notes
MSH-DSCH_Message_Format() {		
<b>Xmt Node Id</b>	16 bits	
}		

## Mesh Addressing Changes

*page 72, line 49, insert*

### 6.5 Data/Control Plane

*Change 6.5.1 heading as follows:*

#### 6.5.1 Addressing and connections in PMP mode

*Insert clause 6.5.2 as follows:*

##### 6.5.2 Addressing in mesh mode

Each node shall have a 48-bit universal MAC address, as defined in IEEE Std 802. The address uniquely defines the node from within the set of all possible vendors and equipment types. This address is used during the network entry process and as part of the authorization process by which the candidate node and the network verify the identity of each other.

When authorized to the network the candidate node shall receive a 16-bit Node Identifier (Node ID) upon a request to the mesh BS. Node ID is the basis for identifying nodes during normal operation. The Node ID is transferred in the Mesh sub-header, which follows the Generic MAC header, in both unicast and broadcast messages.

For addressing nodes in the local neighborhood, 8-bit link identifiers (Link IDs) shall be used. Each node shall assign an ID for each link it has established to its neighbors. The Link IDs are communicated during the Link Establishment process as neighboring nodes establish new links. The Link ID is transmitted as part of the CID in the Generic MAC header in unicast messages. The Link IDs shall be used in distributed scheduling to identify resource requests and grants. Since these messages are broadcast, the receiver nodes shall be able to identify the schedule of their own using both the transmitter's Node ID in the Mesh subheader, and the Link ID in the MSH-DSCH payload.

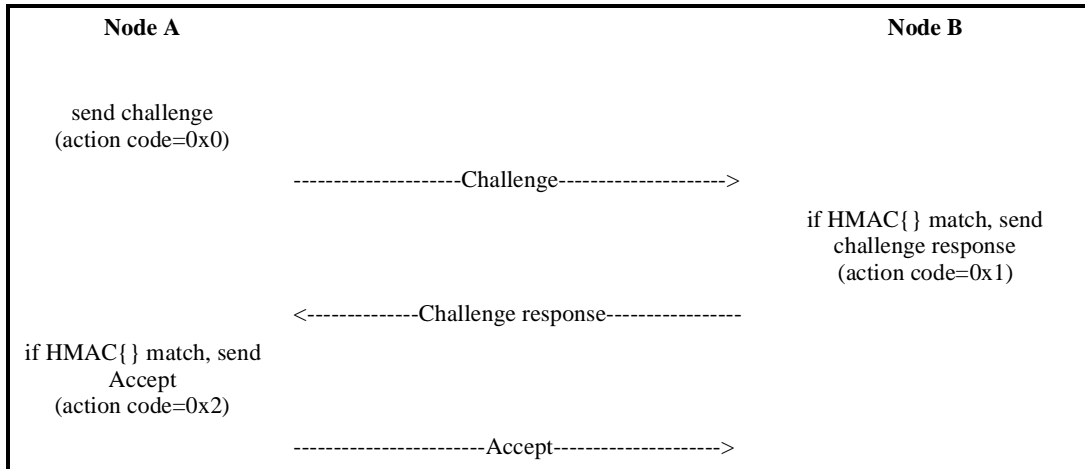
##### 6.5.2.1 Establishing link connectivity

In Mesh mode, after entering the network, a node can establish links with nodes other than its sponsor by following the secure process as defined in Table 3. This process uses the MSH-NCFG:Neighbor Link Establishment IE.

- Node A sends a challenge (action code = 0x0) containing:
  - HMAC{Operator Shared Secret, frame number, Node ID of node A, Node ID of node B}
  - in which the Operator Shared Secret is a private key obtained from the provider (which is also used to enter the network) and the frame number is the last known frame number in which Node B send a MSH-NCFG message.
- Node B, upon reception, computes the same value (it may also attempt some earlier frame numbers in which it sent MSH-NCFG messages, in case node A missed the last of its MSH-NCFGs) as above and compares. If the values don't match a rejection (action code = 0x3) is returned. If a match is achieved, Node B sends, implicitly accepting the link, a challenge response (action code=0x1) containing:
  - HMAC{Operator Shared Secret, frame number, Node ID of node B, Node ID of node A}
  - in which the frame number is the frame number in which Node A sent the MSH-NCFG message with challenge. It also randomly selects and includes an unused link ID, which will from this point forward indicate the link from node B to node A.
  - Node A, upon reception, computes the same value as above and compares. If the values don't match a rejection (action code = 0x3) is returned. If a match is achieved, Node A sends an Accept. It also randomly selects and includes an unused link ID, which will from this point forward indicate the link from node A to

node B.  
•

**Table 3—Establishing link Connectivity**



1  
2  
3  
4  
5  
6  
7  
8  
9  
10  
11  
12  
13  
14  
15  
16  
17  
18  
19  
20  
21  
22  
23  
24  
25  
26  
27  
28  
29  
30  
31  
32  
33  
34  
35  
36  
37  
38  
39  
40  
41  
42  
43  
44  
45  
46  
47  
48  
49  
50  
51  
52  
53  
54  
55  
56  
57  
58  
59  
60  
61  
62  
63  
64  
65

## Mesh Scheduling Changes

1  
2  
3  
4  
5 | *page 21, line 8*

6  
7 Delete CRQS

8  
9  
10 | *page 23, line 55*

11  
12 Delete MSH-CRQS entry

13  
14 | *page 39, line 47 replace 6.2.2.3.35.3 with:*

### 6.2.2.3.35.3 Mesh Distributed Scheduling (MSH-DSCH) message

15  
16  
17  
18  
19  
20 Mesh Distributed Scheduling (MSH-DSCH) messages shall be transmitted in mesh mode when using dis-  
21 tributed scheduling. In coordinated distributed scheduling, all the nodes shall transmit a MSH-DSCH at a  
22 regular interval to inform all the neighbors of the schedule of the transmitting station. This transmission time  
23 is determined by the same algorithm used for MSH-NCFG messages (see clause 6.2.7.6.4.5.1). In both coor-  
24 dinated and uncoordinated scheduling, MSH-DSCH messages shall be used to convey resource requests and  
25 grants to the neighbors. Further the MSH-DSCH messages shall be used to convey information about free  
26 resources that the neighbors can issue grants in. This message shall not be fragmented. The MSH-DSCH  
27 message format is given in Table 4, including all of the following parameters:

#### Co-ordination Flag

28  
29  
30  
31  
32 0 = Coordinated

33 1 = Uncoordinated

34 Coordinated MSH-DSCH transmissions take place in the control subframe (see clause  
35 8.3.5.8.2.1). Uncoordinated MSH-DSCH transmissions take place in the data subframe (see  
36 clause 8.3.5.8.2.1). Both the cases require a three-way handshake (Request, Grant and Grant  
37 confirmation) to establish a valid schedule. Uncoordinated scheduling may only take place in  
38 minislots which cause no interference with the coordinated schedule.

#### Grant/Request Flag

39  
40  
41 0 = Request message

42 1 = Grant message (also used as Grant confirmation)

43  
44 The Request Type indicates that a new Request is made of one or more other nodes. The **No.**  
45 **Requests** must be non-zero in this case. The message may also contain Availabilities and  
46 Grants.

47 The Grant Type indicates that one or more Grants are given or confirmed. The **No. Grants**  
48 must be non-zero in this case. The message may also contain Availabilities and Requests.  
49 Requests in this type of message indicate pending demand to the indicated node(s), but do not  
50 solicit a Grant from this node.

51 This flag is always set to 0 for coordinated distributed scheduling

#### Sequence Counter

52  
53  
54 Sequentially increased counter for solicit messages in uncoordinated scheduling (used as multi-  
55 ple solicits might be outstanding). In coordinated scheduling, it allows nodes to detect missed  
56 scheduling messages.

57 Independent counters are used for the coordinated & uncoordinated messages.

#### No. Requests

58  
59  
60 Number of Request IEs in the message.

#### No. Availabilities

61  
62  
63  
64  
65

Number of Availability IEs in the message. The Availability IEs are used to indicate free minislots ranges that neighbors could issue Grants in.

**No. Grants**

Number of Grant IEs in the message

**Table 4—MSH-DSCH Message Format**

Syntax	Size	Notes
MSH-DSCH_Message_Format() {		
<b>Management Message Type =39</b>	8 bits	
<b>Coordination Flag</b>	1 bits	
<b>Grant/Request Flag</b>	1 bits	
<b>Sequence counter</b>	6 bits	
<b>No. Requests</b>	4 bits	
<b>No. Availabilities</b>	4 bits	
<b>No. Grants</b>	6 bits	
<b>Reserved</b>	2 bits	
if (Coordination Flag == 0) {		
<b>MSH-DSCH_Scheduling_IE()</b>	variable	
}		
for (i=0; i< No_Requests; ++i) {		
<b>MSH-DSCH_Request_IE()</b>	16 bits	
}		
<b>Padding nibble</b>	0 or 4 bits	Pad till byte boundary
for (i=0; i< No_Availabilities; ++i) {		
<b>MSH-DSCH_Availability_IE()</b>	32 bits	
}		
for (i=0; i< No_Grants; ++i) {		
<b>MSH-DSCH_Grant_IE()</b>	40 bits	
}		
}		

**6.2.2.3.35.3.1 MSH-DSCH Scheduling Information Element**

The Coordinated distributed scheduling information carried in the MSH-DSCH message shall be used to distribute information needed to determine transmission timing of the MSH-DSCH messages with coordinated distributed scheduling. Each node shall report the two related parameters both of its own and all its neighbors. The scheduling information shall include all of the following parameters:

**Next Xmt Mx**



**Next Xmt Time** is the next MSH-DSCH eligibility interval for this node and computed as the range

$$2^{\text{Xmt Holdoff Exponent}} \cdot \text{Next Xmt Mx} < \text{Next Xmt Time} \leq 2^{\text{Xmt Holdoff Exponent}} \cdot (\text{Next Xmt Mx} + 1).$$

For example, if **Next Xmt Mx** =3 and **Xmt Holdoff Exponent** =4, then the node shall be considered eligible for its next MSH-DSCH transmission between 49 and 64 (due to the granularity) transmission opportunities away and ineligible before that time.

If the **Next Xmt Mx** field is set to 0x1F (all ones), then the neighbor should be considered to be eligible to transmit from the time indicated by this value and every MSH-DSCH opportunity thereafter (i.e. treat **Xmt Holdoff Time** = 0).

#### **Neighbor Next Xmt Mx**

Advertises the **Next Xmt Mx** as reported by this neighbor.

#### **Xmt Holdoff Exponent**

The **Xmt Holdoff Time** is the number of MSH-DSCH transmit opportunities after **Next Xmt Time** (there are MSH-CTRL-LEN – 1 opportunities per network control subframe, see clause 8.3.5.8.2.1), that this node is not eligible not transmit MSH-DSCH packets (see clause 6.2.7.6.4.5.1).

$$\text{Xmt Holdoff Time} = 2^{(\text{Xmt Holdoff Exponent} + 4)}$$

#### **Neighbor Xmt Holdoff Exponent**

Advertises the **Xmt Holdoff Exponent** as reported by this neighbor.

#### **No. SchedEntries**

Number of Neighbor MSH-DSCH Scheduling Entries in the message.

#### **Neighbor Node ID**

The Node ID of the neighbor being reported on.

**Table 5—MSH-DSCH Scheduling Information Element**

Syntax	Size	Notes
MSH-DSCH_Scheduling_IE() {		
<b>Next Xmt Mx</b>	5 bits	
<b>Xmt holdoff exponent</b>	3 bits	
<b>No. SchedEntries</b>	8 bits	
for (i=0; i< No_SchedEntries; ++i) {		
<b>Neighbor Node ID</b>	16 bits	
<b>Neighbor Next Xmt Mx</b>	5 bits	
<b>Neighbor Xmt holdoff exponent</b>	3 bits	
}		
}		

### 6.2.2.3.35.3.2 MSH-DSCH Request Information Element

The Requests carried in the MSH-DSCH message shall convey resource requests on per link basis. The Requests shall include all of the following parameters:

**Table 6—MSH-DSCH Request Information Element**

Syntax	Size	Notes
MSH-DSCH_Request_IE() {		
<b>Link ID</b>	8 bits	
<b>Demand Level</b>	8 bits	
<b>Persistence</b>	3 bits	
<b>Reserved</b>	1 bit	
}		

#### **Link ID**

The ID assigned by the transmitting node to the link to this neighbor that this request involves.

#### **Demand level**

Demand in minislots (assuming the current burst profile):

#### **Demand Persistence**

Persistency field for demands. Number of frames over which the demand exists.

0 = cancel reservation

1 = single frame

2 = 2 frames

3 = 4 frames

4 = 8 frames

5 = 32 frames

6 = 128 frames

7 = Good until canceled or reduced

### 6.2.2.3.35.3.3 MSH-DSCH Availabilities Information Element

The Availabilities carried in the MSH-DSCH message shall be used to indicate free minislot ranges that neighbors could issue Grants in. The Availabilities shall include all of the following parameters:

**Table 7—MSH-DSCH Availability Information Element**

Syntax	Size	Notes
MSH-DSCH_Availability_IE() {		
<b>Start Frame number</b>	8 bits	8 lsb of Frame number
<b>Minislot start</b>	8 bits	
<b>Minislot range</b>	7 bits	
<b>Direction</b>	2 bit	
<b>Persistence</b>	3 bits	
<b>Channel</b>	4 bits	
}		

#### Neighbor ID

The ID assigned by the transmitting node to the neighbor that this availability information involves.

#### Start Frame number

Availability start:

Indicates lowest 8 bits of frame number in which the availability starts.

#### Minislot start

The start position of the availability within a frame (minislots as time unit, see 8.3.5.8.2.1 for definition).

#### Minislot range

The number of minislots free for grants

#### Direction

0 = Minislot range is unavailable.

1 = Available for transmission in this minislot range.

2 = Available for reception in this minislot range.

3 = Available for either transmission or reception

#### Persistence

Persistency field for Availabilities. Number of frames over which the Availability is valid.

0 = cancel availability

1 = single frame

2 = 2 frames

3 = 4 frames

4 = 8 frames

5 = 32 frames

6 = 128 frames

7 = Good until canceled or reduced

#### Channel

Logical channel number, which is the logical number of the physical channel (see Table 222), .

A subset of the possible physical channel numbers is mapped to logical channels in the Network Descriptor.

### 6.2.2.3.35.3.4 MSH-DSCH Grants Information Element

The Grants carried in the MSH-DSCH message shall convey information about a granted minislot range selected from the range reported as available. Grants shall be used both to grant and confirm a grant. The Grants shall include all of the following parameters:

**Table 8—MSH-DSCH Grants Information Element**

Syntax	Size	Notes
MSH-DSCH_Grants_IE() {		
<b>Link ID</b>	8 bits	
<b>Start Frame number</b>	8 bits	8 lsb of Start Frame number
<b>Minislot start</b>	8 bits	
<b>Minislot range</b>	8 bits	
<b>Direction</b>	1 bit	
<b>Persistence</b>	3 bits	
<b>Channel</b>	4 bits	
}		

#### **Link ID**

The ID assigned by the transmitting node to the neighbor that this grant involves.

#### **Start Frame number**

Schedule start:

Indicates lowest 8 bits of frame number in which the schedule is granted.

#### **Minislot start**

The start position of the reservation within a frame (minislots as time unit, see 8.3.5.8.2.1 for definition).

#### **Minislot range**

The number of minislots reserved

#### **Direction**

0= From requester (i.e. to granter)

1= To requester (i.e. from granter)h

#### **Persistence**

Persistency field for grants. Number of frames over which the grant is allocated.

0 = cancel reservation

1 = single frame

2 = 2 frames

3 = 4 frames

4 = 8 frames

5 = 32 frames

6 = 128 frames

7 = Good until canceled or reduced

#### **Channel**

Logical channel number, which is the logical number of the physical channel (see Table 222), .

A subset of the possible physical channel numbers is mapped to logical channels in the Network Descriptor.

#### 6.2.2.3.35.4 Centralized mesh scheduling (MSH-CSCH) message

A Mesh Centralized Scheduling (MSH-CSCH) message shall be created by a mesh BS when using centralized scheduling. The BS will broadcast the MSH-CSCH message to all its neighbors, and all the nodes with hop count lower than  $HR_{\text{threshold}}$  shall forward the MSH-CSCH message to their neighbors that have a higher hop count. In all these cases, the **Grant/Request Flag** =0.  $HR_{\text{threshold}}$  is a configuration value that need only be known to the mesh BS, as it can be derived by the other nodes from the MSH-CSCF message.

Nodes can use MSH-CSCH messages to request bandwidth from the mesh BS setting the **Grant/Request Flag** =1. Each node reports the individual traffic demand requests of each “child” node in its subtree from the BS. The nodes in the subtree are those in the current scheduling tree to and from them mesh BS, known to all nodes in the network, and ordered by node ID.

The BS shall generate MSH-CSCHs in the format shown in Table 9, including all of the following parameters:

##### **Configuration sequence number**

Indicates the configuration, which shall be used to interpret this packet. It refers to the configuration number in the MSH-CSCF packet.

##### **Grant/Request Flag**

0=Grant (transmitted in downstream)

1=Request (transmitted in upstream)

##### **Flow Scale Exponent**

Determines scale of the granted bandwidth. Its value typically depends on the number of nodes in the network, the achievable PHY bitrate, the traffic demand and the provided service.

For downstream, this gives the absolute values of flow granted, so the total minislot range allowed for centralized scheduling need not be used if not needed, with the remainder set aside for distributed scheduling.

For upstream, the lowest exponent possible is used at each hop, with quantization of forwarded requests rounded up (e.g., avoids reducing any requests to zero).

##### **NumFlowEntries**

Number of 8-bit assignment fields followed, ordered according to appearance in MSH-CSCF. This number must match the number of entries in the most recent MSH-CSCF message

##### **UpstreamFlow**

Base of the granted/requested bandwidth as bits/s for the upstream traffic of the node in the BS’s scheduling tree. The allocation is the same the same as for **DownstreamFlow**.

##### **DownstreamFlow**

Base of the granted/requested bandwidth as bits/s for the downstream respectively upstream traffic of the node in the BS’s scheduling tree. The flow only indicates only traffic that initiates or terminates in the node itself (i.e. forwarded traffic is not included), except for traffic forwarded from/to nodes not part of the MSH-CSCF tree. The actual granted/requested bandwidth shall be calculated as

$$BW = \text{UpstreamFlow} * (2^{\text{FlowScale Exponent}+14}) \text{ bits/s, for traffic to the BS.}$$

$$BW = \text{DownstreamFlow} * (2^{\text{FlowScale Exponent}+14}) \text{ bits/s, for traffic from the BS.}$$

The assignments in the list are ordered according to the order in the MSH-CSCF message (see clause 6.2.2.3.35.5).

The usage of the assignments to compute the actual transmission schedule is TBD.

##### **Frame schedule flag**

If this flag is set, the allocation of flows shall occur over two frames, rather than one.

Table 9—MSH-CSCH Message Format

Syntax	Size	Notes
MSH-CSCH_Message_Format() {		
<b>Management Message Type = 40</b>	8 bits	
<b>Configuration sequence number</b>	3 bits	Last MSH-CSCF sequence number
<b>Grant / Request Flag</b>	1 bits	0 = Grant 1 = Request
<b>Flow Scale Exponent</b>	4 bits	
<b>Frame schedule Flag</b>	1 bits	
<b>NumFlowEntries</b>	8 bits	
for (i=0; i< NumFlowEntries; ++i) {		
<b>UpstreamFlow</b>	4 bits	
<b>DownstreamFlow</b>	4 bits	
}		
}		

#### 6.2.2.3.35.5 Mesh centralized scheduling configuration (MSH-CSCF) message

A Mesh Centralized Scheduling Configuration (MSH-CSCF) message shall be broadcast in mesh mode when using centralized scheduling. The mesh BS shall broadcast the MSH-CSCF message to all its neighbors, and all nodes shall forward (rebroadcast) the message according to its index number specified in the message. The BS shall generate MSH-CSCFs in the format shown in Table 10, including all of the following parameters:

**Configuration sequence number**

Number of the configuration. With each new configuration message, the number is incremented by 1.

**HopRange Threshold**

The number of hops the MSH-CSCF and MSH-CSCH messages shall be forwarded over. This also indicates the hop range over which the centralized schedule is computed and relevant.

**NumberOfChannels**

Number of channels available for centralized scheduling.

**Channel Index**

The logical index of the Physical channel, as reported in MSH-NCFG:NetworkDescriptor.

**NumberOfNodes**

Number of nodes in scheduling tree

Each entry of the scheduling tree shall include all of the following parameters:

**Node ID**

Unique node identifier assigned to node.

**NumberOfChildren**

Number of child nodes for this node. A child node is a neighbor with a hop count, which is one higher than this nodes hop count.

**ChildIndex**

**NumberOfChildren** index in this table of child node.

**Upstream/Downstream Burst Profile**

Burst profile of link from/to child node.

**Table 10—MSH-CSCF Message Format**

Syntax	Size	Nodes
MSH-CSCH_Message_Format() {		
<b>Management Message Type = 41</b>	8 bits	
<b>Configuration sequence number</b>	3 bits	
<b>Reserved</b>	1 bit	
<b>NumberOfChannels</b>	4 bits	
for (i=0; i< NumberOfChannels; ++i) {		
<b>Channel index</b>	4 bits	
}		
<b>Padding Nibble</b>	0 or 4 bits	Pad till byte boundary
<b>NumberOfNodes</b>	8 bits	
for (i=0; i< NumberOfNodes; ++i) {		
<b>NodeID</b>	16 bits	Node index for this node is thus $i$
<b>NumOfChildren</b>	8 bits	
for (j=0; j< NumberOfChildren; ++j) {		
<b>Child Index</b>	8 bits	index of $j^{\text{th}}$ child node
<b>Upstream Burst Profile</b>	4 bits	burst profile from $j^{\text{th}}$ child node
<b>Downstream Burst Profile</b>	4 bits	burst profile to $j^{\text{th}}$ child node
}		
}		
}		

**page 45, line 24:**

replace XmtNbrID and RcvNbrID with “Receiver’s **Node ID**” and delete lines 37 through 41.

**page 55, line 61, add at end of clause 6.2.6.6.1:**

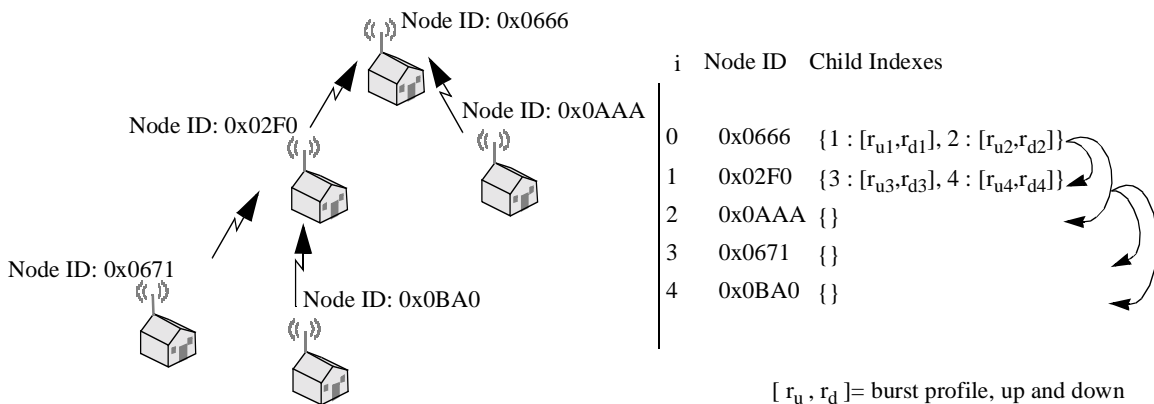
Both the coordinated and uncoordinated distributed scheduling employ a three-way handshake.

- A MSH-DSCH:Request is made along with MSH-DSCH:Avalabilities, which indicate potential slots for replies and actual schedule.
- A MSH-DSCH:Grant is send in response indicating a subset of the suggested availabilities which fits, if possible, the request. The neighbors of this node not involved in this schedule will assume the transmission takes place as granted.
- A MSH-DSCH:Grant is send by the original requester containing a copy of the grant from the other party, to confirm the schedule to the other party. The neighbors of this node not involved in this schedule will assume the transmission takes place as granted.

The differences between coordinated and uncoordinated distributed scheduling is, that in the coordinated case, the MSH-DSCH messages are scheduled themselves in the control subframe in a collision free manner, whereas in the uncoordinated case, MSH-DSCH messages may collide. Nodes responding to a Request should, in the uncoordinated case, wait a sufficient number of minislots of the indicated Availabilities before responding with a grant, such that nodes listed earlier in the Request have an opportunity to respond.

**page 56, line 53, add:**

A simple example of the use of the centralized scheduling flow-mechanism in MSH-CSCF is provided. For the network shown in Figure 2, the requested flows are shown. The data rate is assumed to be the burst profile number (for simplicity) as shown in Figure 1.

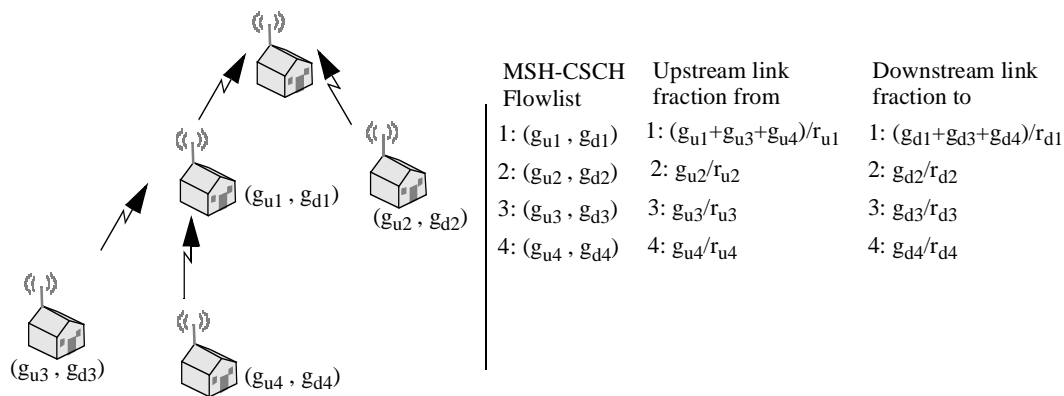


**Figure 1—MSH-CSCF schedule example**

The link fractions shown in Figure 2 are multiplied with  $(2^{\text{FlowScale Exponent}+14})$  and with the frame duration, then rounded up to the nearest duration of a whole number of minislots required to transmit this fraction (including preamble).

Each node shall ensure that the duration of all resulting minislot allocations per channel does not exceed the available minislot space (in one or two frames depending on the **Frame schedule flag**) by reducing all allocations proportionally. Each node shall then recursively round down the number of minislots of the allocation with the smallest decimal fraction and add another minislot to the allocation with the largest decimal fraction. Before transmitting the schedule, the mesh BS shall ensure that this computation does not result in non-zero allocations smaller than required to transmit a preamble and one data symbol.





20  
21  
22  
23  
24  
25  
26  
27  
28  
29  
30  
31  
32  
33  
34  
35  
36  
37  
38  
39  
40  
41  
42  
43

**Figure 2—MSH-CSCF flow usage example**

The number of frames over which the CSCF schedule is valid is limited by the number of frames it takes to aggregate and distribute the next schedule.

Each node uses the newly received schedule to compute its retransmission time (if eligible) and the last frame when a node will be receiving this schedule, as well as the time when the mesh BS sent it. To compute this, the node uses the routing tree from the last MSH-CSCF messages (which dictates the size of MSH-CSCF messages) and the following rules:

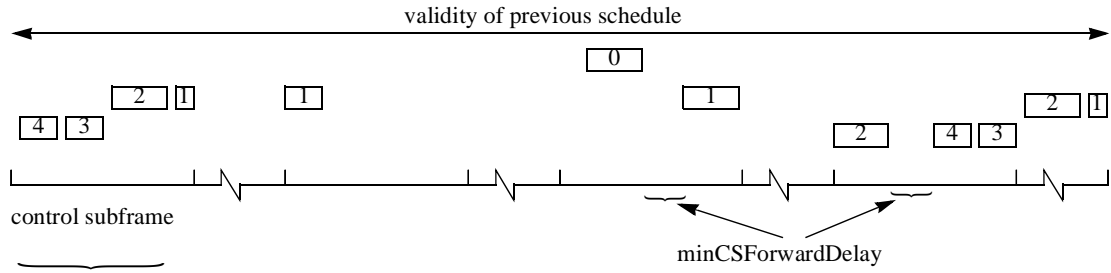
- The mesh BS transmits first in a new frame.
- Then, the eligible children of the mesh BS (i.e., nodes with hop count equal 1) in the most recent MSH-CSCF packet transmit next, ordered by their appearance in the MSH-CSCF packet, transmit.
- Then, the eligible children of the nodes from step 2 (i.e., nodes with hop count equal 2), also ordered by their appearance in the MSH-CSCF packet, transmit.
- ...continue until all eligible nodes in the routing tree have transmitted.
- Nodes shall fragment their message if it does not fit entirely before the end of the control subframe and at least the preamble and one data symbol fit.
- All nodes are eligible to transmit the grant schedule, except those that have no children.
- If a node's order requires it to transmit immediately after receiving, a delay of **MinCSForwardingDelay**  $\mu s$  is inserted.

Each node shall also compute the timing of the upstream requests. Upstream requests start in the last frame in which a node received the previous schedule. All nodes are eligible to transmit requests, except the mesh BS. The request transmission order is the reverse of the grant transmission order.

The time between the first frame in which a node sends the request schedule and the last frame in which a node receives the new grant schedule marks the validity of the previous grant schedule. This validity time overrides the **Frame schedule flag** two frame usage at the end of the validity time. Note that MSH-CSCF messages may be sent after the last request is received and before the grant schedule is transmitted by the mesh BS.

44  
45  
46  
47  
48  
49  
50  
51  
52  
53  
54  
55  
56  
57  
58  
59  
60  
61  
62  
63  
64  
65

1  
2  
3  
4  
5  
6  
7  
8  
9  
10  
11  
12  
13  
14  
15  
16  
17  
18  
19  
20  
21  
22  
23  
24  
25  
26  
27  
28  
29  
30  
31  
32  
33  
34  
35  
36  
37  
38  
39  
40  
41  
42  
43  
44  
45  
46  
47  
48  
49  
50  
51  
52  
53  
54  
55  
56  
57  
58  
59  
60  
61  
62  
63  
64  
65



**Figure 3—MSH-CSCH schedule validity**

## Mesh Synchronization and Entry Changes

*page 26, line 39, insert 6.2.2.3.7 through 6.2.2.3.9 text*

### 6.2.2.3.7 Registration Request (REG-REQ) message

*Insert at end of clause:*

In Mesh Mode during Registration the Registration Node shall generate REG-RSP messages including the following parameters:

- Node ID
- MAC Version
- MAC Version used in the network
- HMAC Tuple
- Message digest calculated using HMAC\_KEY\_D

The REG-RSP may in addition contain the following parameters:

- IP Version
- SS Capabilities Encodings
- Capabilities returned in the REG-RSP shall not be set to require greater capability of the Node than is reported in the REG-REQ.
- Vendor Specific Extensions

### 6.2.2.3.8 Registration Response (REG-RSP) message

*Insert at end of clause:*

In Mesh Mode during Registration the Candidate Node shall generate REG-REQ messages including the following parameters:

- SS MAC Address
- MAC Version
- The MAC version implemented in the Candidate Node
- HMAC Tuple
- Message digest calculated using HMAC\_KEY\_U

The REG-REQ may in addition contain the following parameters:

- IP Version
- SS Capabilities Encodings
- Vendor ID Encoding

### 6.2.2.3.9.3 Authorization Reply (Auth Reply) message

**Append Table 11 to table 28**

**Table 11—Authorization reply attributes**

Attributes	Contents
Operator Shared Secret	Mesh Mode Only. Key known to all
Key-Sequence-Number	Mesh Mode Only. Sequence number of the Operator Shared Secret
Key-Lifetime	Mesh Mode Only. Lifetime of the Operator Shared Secret

### 6.2.2.3.9.5 Key Request message

**Insert before “The HMAC digest attribute**

When operating in Mesh Mode the attributes of the Key Request message shall be those of Table 12.

**Table 12—Key Request Attributes for Mesh Mode**

Attribute	Contents
SS Certificate	X.509 Certificate of the Node
SAID	SA Identifier
HMAC-Digest	HMAC using HMAC_KEY_S

**Change:**

The HMAC-Digest’s authentication key is derived from Authorization key. The HMAC-Digest’s authentication key is derived from the Authorization key or the Operator Shared Secret.

**page 31, line 33:**

Add to MSH-NCFG() at the end of Timestamp field:

Synchronization hop count                      8 bits

**page 33, line 21**

#### **Synchronization hop count**

This counter is used to determine superiority between nodes when synchronizing the network. Nodes can be assigned as master time keepers, which are synchronized externally (for example using GPS). These nodes transmit a Synchronization hop count of 0. Nodes shall synchronize to nodes with lower synchronization hop count, or if counts are the same, to the node with the lower Node ID.

**page 35, lines 34: replace Network Entry Close line with:**

0x4: Network Entry Ack (Embedded\_data\_IE() == NULL )

0x5: Neighbor Link Establishment Protocol

**page 36, line 32:**

Add in Notes of Channels: Ordered with channels with same regulatory rules successive.  
 Replace **Logical Network ID** entry with **MinCSForwardingDelay**, 7 bits, Number of OFDM symbols  
 change **Physical channel codes** to 8 bits  
 Add after scheduling frames: **MSH-CSCH-slots**, 8 bits, Number of minislots  
 Add at end of message

**Table 13—Network Descriptor Information Element (addendum)**

Syntax	Size	Notes
MSH-NCFG_embedded_data_IE() {		
<b>Channel re-use</b>	3 bits	
<b>Peak/Average flag</b>	1 bits	Regulatory limits are peak or average.
<b>Reserved</b>	2 bits	
<b>NumChannelMaps</b>	2 bits	
for (i=0; i< NumChannelMaps; ++i) {		
<b>Number of Channels</b>	8 bits	Nodes in channel map to which rules apply
<b>Max. xmt power at antenna port</b>	6 bits	Regulatory limit in dBm
<b>Max. EIRP</b>	6 bits	Regulatory limit in dBm
}		
}		

add:

**MinCSForwardingDelay**

The minimum delay in OFDM symbols that shall be inserted between the end of reception and the start of transmission of a Centralized Scheduling message (i.e MSH-CSCH and MSH-CSCF) by any node.

**MSH-CSCH-slots**

The number of minislots at the start of each data subframe allocated for centralized scheduling.

**Channel re-use**

Minimum number of hops of separation between links, before a channel can be re-used by the centralized scheduling algorithm. Range is 1 hop to 7 hops. 0 for no re-use.

**page 37, line 13**

Delete Node ID entry

1 | **page 37, line 28, replace the Sponsor Neighbor ID with the following:**

2  
3       **Estimated Propagation Delay**4 bits μs  
4       **Reserved**4 bits

7 | **add on page 37, line 51 (and delete TBD from table above)**

9       **Rejection Code**  
10       0x0: Operator Authentication Value Invalid  
11       0x1: Excess Propagation delay  
12       0x2: Select new sponsor

15 | **page 37, line 52, add the following table:**

21       **Table 14—Neighbor Link Establishment Information Element**

Syntax	Size	Notes
MSH-NCFG_embedded_data_IE() {		
<b>Action Code</b>	2 bits	0x0 Challenge 0x1 Challenge response 0x2 Accept 0x3 Reject
<b>Reserved</b>	6 bits	
if ( Action Code == 0x0 or 0x1)		
<b>Nbr Authentication value</b>	32 bits	
if ( Action Code == 0x1 or 0x2)		
<b>Link ID</b>	8 bits	Transmitting node’s link ID for this link
}		

45       **N br Authentication value**

46       HMAC{Authorization Key | frame number | own Node ID, Node ID of other node} where the  
47       Authorization Key is a secret key (obtained from Operator)

50 | **add page 38, line 17**

52       0x3 NetEntryClose

55 | **page 39, line 18:**

57       Delete capabilities

61 | **page 58, line 54, add:**

62       **Synchronization hop count**

This counter is used to determine superiority between nodes when synchronizing the network. Nodes can be assigned as master time keepers, which are synchronized externally (for example using GPS). These nodes transmit Synchronization hop count of 0. Nodes shall synchronize to nodes with lower synchronization hop count, or if counts are the same, to the node with the lower Node ID.

*page 60, line 20 replace clause 6.2.7.6.4.4 and 6.2.7.6.4.5*

#### 6.2.7.6.4.4 Mesh Network Synchronization

Network configuration (MSH-NCFG) and network entry (MSH-NENT) packets provide a basic level of communication between nodes in different nearby networks whether from the same or different equipment vendors or wireless operators. These packets are used to synchronize both centralized and distributed control mesh networks.

This communication is used to support basic configuration activities such as: synchronization between nearby networks used (for instance, for multiple, co-located BSs to synchronize their upstream and downstream transmission periods), communication and coordination of channel usage by nearby networks, and discovery and basic network entry of new nodes.

MSH-NCFG, MSH-NENT and MSH-DSCH can all assist a node in synchronizing to the start of frames. For these messages, the control subframe, which initiates each frame, is divided into transmit opportunities (see clause 8.3.5.8.2.1). The first transmit opportunity in a network control subframe may only contain MSH-NENT messages, while the remainder **MSH-CTRL-LEN-1** may only contain MSH-NCFG messages. In scheduling control subframes, the **MSH-DSCH-NUM** transmit opportunities assigned for MSH-DSCH messages come last in the control subframe. The MSH-NCFG messages also contain the number of its transmit opportunity, which allows nodes to easily calculate the start time of the frame.

#### 6.2.7.6.4.5 MSH-NCFG/MSH-NENT Transmission Timing

MSH-NCFG and MSH-NENT packets are scheduled for transmission during control subframes. So that all nearby nodes receive these transmissions, the channel used is cycled through the available channels in the band, with the channel selection being based on the Frame number. So, for frame number  $i$ , the channel is determined by the array lookup:

$$\text{NetConfigChannel} = \text{Logical channel list}[(\text{Frame Number} / (\text{Scheduling Frames} \cdot 4 + 1)) \% \text{Number of logical channels}]$$

where the Logical channel List and **Scheduling Frames** are derived from the MSH-NCFG:Network Descriptor (see clause 6.2.2.3.35.1.3). The location within frames, burst profile etc.. of MSH-NCFG and MSH-NENT packets are described in clause 8.3.5.8.2.1.

*page 60, line 64*

*Delete line 64 “if..” through line 2 “else” (fix indentation accordingly)*

*Replace next two lines with “*

Determine the eligible competing nodes, which is the set of all nodes in the physical-neighbor list with a **Next Xmt Time** eligibility interval which includes **TempXmtTime** or with an **Earliest Subsequent Xmt Time** equal to or smaller than **TempXmtTime**.

*page 61, line 8:*

*Change ‘MAC addresses’ to ‘Node IDs’*

1  
2  
3  
4  
5  
6  
7  
8  
9  
10  
11  
12  
13  
14  
15  
16  
17  
18  
19  
20  
21  
22  
23  
24  
25  
26  
27  
28  
29  
30  
31  
32  
33  
34  
35  
36  
37  
38  
39  
40  
41  
42  
43  
44  
45  
46  
47  
48  
49  
50  
51  
52  
53  
54  
55  
56  
57  
58  
59  
60  
61  
62  
63  
64  
65

*page 61, line 24: replace uint32 MyMacAdr with uint16 NodeID, and uint32 MacAdrList[] with uint16 NodeIDList[]*

*page 61, lines 25 through 56, replace MyMacAdr with MyNodeID, and MacAdrList with NodeIDList*

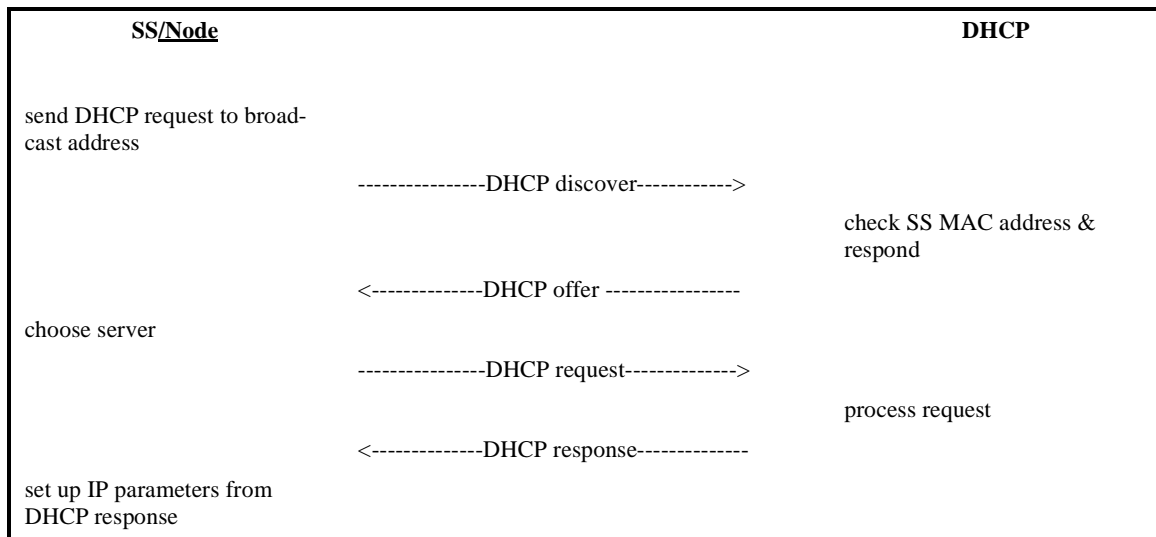
*page 63, line 61: delete “If ..” through “mobility.)*

*page 66, line 46, insert:*

**6.2.9.10 Establish IP Connectivity**

*Change Table 62 as shown in Table 15*

**Table 15—Establishing IP Connectivity**



*page 66, line 50 replace clause 6.2.9.13 with:*

**6.2.9.13 Network Entry and synchronization in Mesh mode**

Node initialization and network entry procedures in mesh mode are in some aspects different from those in PMP mode. The procedures that apply to the mesh mode are described in this clause. A new node entering the mesh network obeys the following procedures. The whole entry process to the stage when the node can start scheduled transmissions can be divided into the following phases:

- a) Scan for active network and establish coarse synchronization with the network
- b) Obtain network parameters (from MSH-NCFG messages)
- c) Open Sponsor Channel
- d) Node authorization
- e) Perform registration
- f) Establish IP connectivity



- g) Establish time of day
- h) Transfer operational parameters

Each node contains the following information when shipped from the manufacturer:

- a) A 48-bit universal MAC address (per IEEE Std 802) assigned during the manufacturing process. This is used to identify the node to the various provisioning servers during initialization and whenever performing authentication with a neighbor node.

### 6.2.9.13.1 Scanning and coarse synchronization to the network

On initialization or after signal loss, the node shall search for MSH-NCFG messages to acquire coarse synchronization with the network. Upon receiving a MSH-NCFG message the node acquires a kind of network time from the **Timestamp** field of the message. The node may have non-volatile storage in which all the last operational parameters are stored and shall first try to re-acquire coarse synchronization with the network. If this fails, it shall begin to continuously scan the possible channels of the frequency band of operation until a valid network is found.

Once the PHY has achieved synchronization, the MAC Sublayer shall attempt to acquire network parameters. At the same time the node shall build a physical neighbor list.

### 6.2.9.13.2 Obtain network parameters

A node shall remain in synchronization as long as it receives MSH-NCFG messages. A node shall accumulate MSH-NCFG messages at least until it receives a MSH-NCFG message from the same node twice and until it has received a MSH-NCFG:Network Descriptor with an operator ID matching (one of) its own if it has any. In parallel the new node shall build a physical neighbor list (see 6.2.7.6.4.1) from the acquired information.

From the established physical neighbor list, the new node shall select a potential Sponsoring Node out of all nodes having the Logical Network ID of the node for which it found a suitable Operator ID. The new node then shall then synchronize its time to the potential sponsor assuming 0 propagation delay after which it shall send a MSH-NENT:NetEntryRequest including the Node ID of the potential sponsor. To determine a suitable transmission time, the node shall adhere to clause 6.2.7.6.4.5.2.

Until the node has obtained an unique Node ID (see 6.2.9.13.5), it shall use temporary Node ID (0x0000) as Transmitter's Node ID in all transmissions.

Once the Candidate Node has selected a Sponsoring Node, it shall use the Sponsoring Node to negotiate basic capabilities and to perform authorization. For that purpose the Candidate Node shall first request the Sponsoring Node to open Sponsor Channel for more effective message exchange.

### 6.2.9.13.3 Open Sponsor Channel

Once the new node has selected one of its neighbors as the candidate Sponsoring Node it becomes a Candidate Node. To get further in the initialization procedure the Candidate Node shall request the candidate Sponsoring Node to establish a temporary schedule which could be used for further message delivery during the Candidate Node initialization. The temporary schedule requested is termed Sponsor Channel.

The process is initiated by the Candidate Node which transmits a MSH-NENT:NetEntryRequest message (a MSH-NENT message with Type set to 0x2) to the Sponsoring Node.

Upon reception of the MSH-NENT:NetEntryRequest message with the Sponsor Node ID equal to Node ID of its own, the candidate Sponsoring Node shall assess the request and either opens the Sponsor Channel or

1 rejects the request. The response is given in a MSH-NCFG message with an Embedded Data as defined in  
2 6.2.2.3.35.1.3. If the candidate Sponsoring Node does not advertise the Candidate Node's MAC address in  
3 the sponsor's next MSH-NCFG transmission, then the procedure is repeated MSH\_SPONSOR\_ATTEMPTS  
4 times using a random backoff between attempts. If these attempts all fail, then a different Candidate Spon-  
5 soring Node is selected and the procedure repeated (including re-initializing coarse network synchroniza-  
6 tion). If the selected candidate Sponsoring Node does advertise the Candidate Node's MAC address, it shall  
7 continue to advertise this MAC address in all its MSH-NCFG messages until the sponsorship is terminated.  
8  
9

10  
11  
12  
13 Once the Candidate Node has received a positive response (a NetworkEntryOpen message) in from the can-  
14 didate Sponsoring Node in the MSH-NCFG message, it shall acknowledge the response by transmitting a  
15 MSH-NENT:NetEntryAck message (a MSH-NENT message with Type set to 0x1) to the Sponsoring Node  
16 at the first following network entry transmission opportunity (see clause 8.3.5.8.2.1). Before that the Candi-  
17 date Node shall perform fine time synchronization. It makes a correction to its transmission timing by the  
18 **Estimated propagation delay** indicated in the embedded MSH-NCFG:NetEntryOpen message.  
19

20  
21 If the Sponsoring Node accepted the request and opened a Sponsor Channel, the channel is ready for use  
22 immediately after the transmission of the acknowledgement message. At the same the candidate Sponsoring  
23 Node becomes the Sponsoring Node.  
24

25  
26 If the candidate Sponsoring Node embedded a MSH-NCFG:NetEntryReject, the new node shall perform the  
27 following action based on the rejection code:  
28

29  
30 0x0: Operator Authentication Value Invalid

31 The Candidate Node shall select a new candidate Sponsoring Node with a different operator  
32 ID.

33  
34 0x1: Excess Propagation delay

35 The Candidate Node shall repeat its MSH-NENT:NetEntryRequest in the following network  
36 entry transmission opportunity to the same candidate Sponsoring Node.

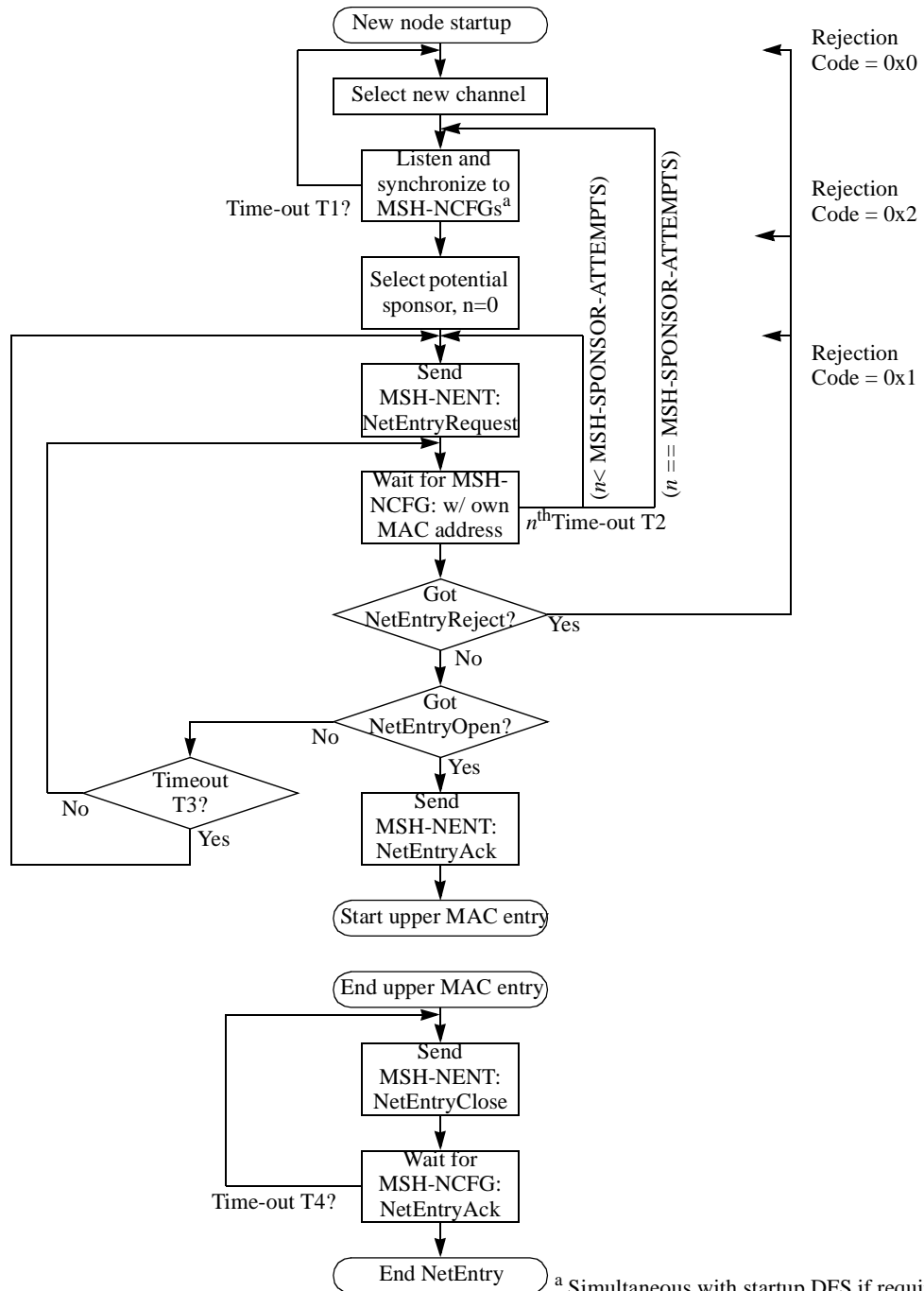
37  
38 0x2: Select new sponsor

39 The Candidate Node shall select a new candidate Sponsoring Node  
40

41 If the candidate Sponsoring Node embedded neither MSH-NCFG:NetEntryOpen nor MSH-NCFG:NetEn-  
42 tryReject, the Candidate Node shall wait (with timeout time T2), for the next MSH-NCFG with NetEntry-  
43 Open from the candidate Sponsoring Node and resend the MSH-NENT:NetEntryRequest on timeout.  
44

45 The Candidate Node and the Sponsoring Node use the schedule indicated in the NetEntryOpen message to  
46 perform message exchanges described in 6.2.9.13.4 through 6.2.9.13.9. After this is completed, the Candi-  
47 date Node shall terminate the entry process by sending a MSH-NENT:NetEntryClose message to the Spon-  
48 soring Node in the network entry transmission immediately following a MSH-NCFG transmission from the  
49 Sponsoring Node, which shall Ack termination with MSH-NCFG:NetEntryAck.  
50  
51  
52  
53  
54  
55  
56  
57  
58  
59  
60  
61  
62  
63  
64  
65

1  
2  
3  
4  
5  
6  
7  
8  
9  
10  
11  
12  
13  
14  
15  
16  
17  
18  
19  
20  
21  
22  
23  
24  
25  
26  
27  
28  
29  
30  
31  
32  
33  
34  
35  
36  
37  
38  
39  
40  
41  
42  
43  
44  
45  
46  
47  
48  
49  
50  
51  
52  
53  
54  
55  
56  
57  
58  
59  
60  
61  
62  
63  
64  
65



<sup>a</sup> Simultaneous with startup DFS if required

**Figure 4—Mesh network synchronization and entry - New node**

1  
2  
3  
4  
5  
6  
7  
8  
9  
10  
11  
12  
13  
14  
15  
16  
17  
18  
19  
20  
21  
22  
23  
24  
25  
26  
27  
28  
29  
30  
31  
32  
33  
34  
35  
36  
37  
38  
39  
40  
41  
42  
43  
44  
45  
46  
47  
48  
49  
50  
51  
52  
53  
54  
55  
56  
57  
58  
59  
60  
61  
62  
63  
64  
65

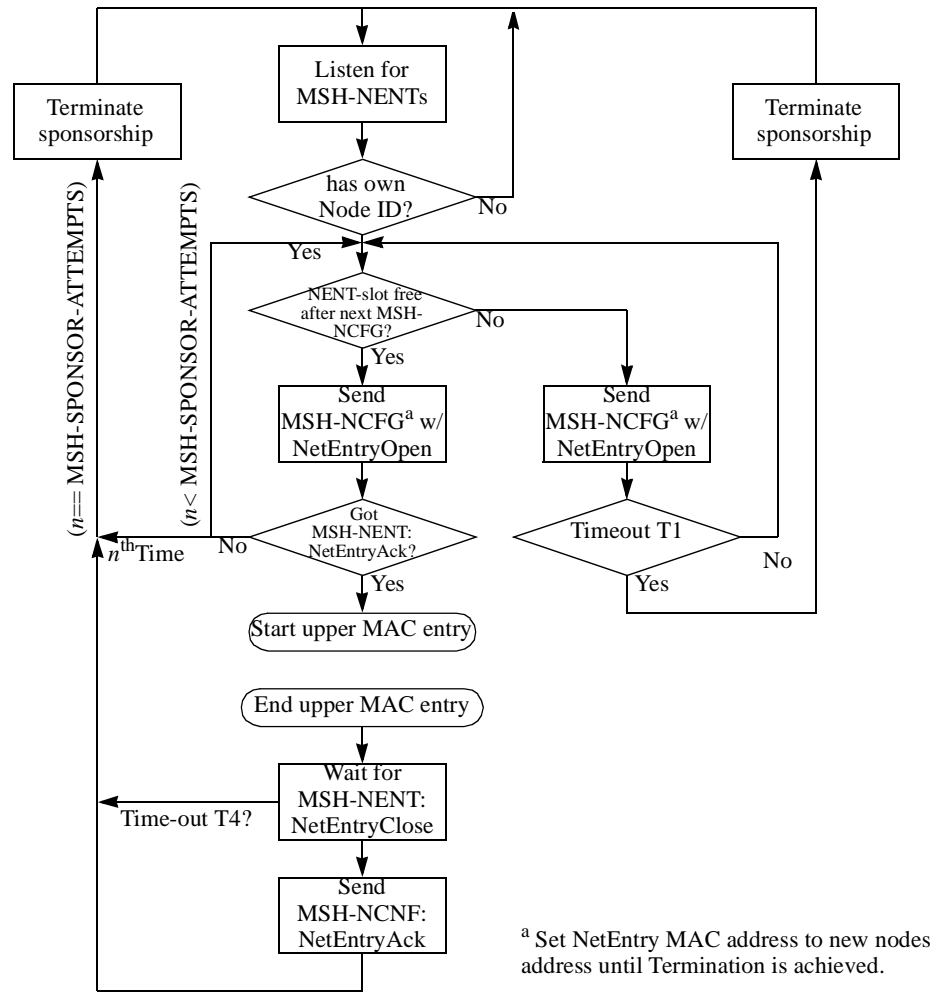
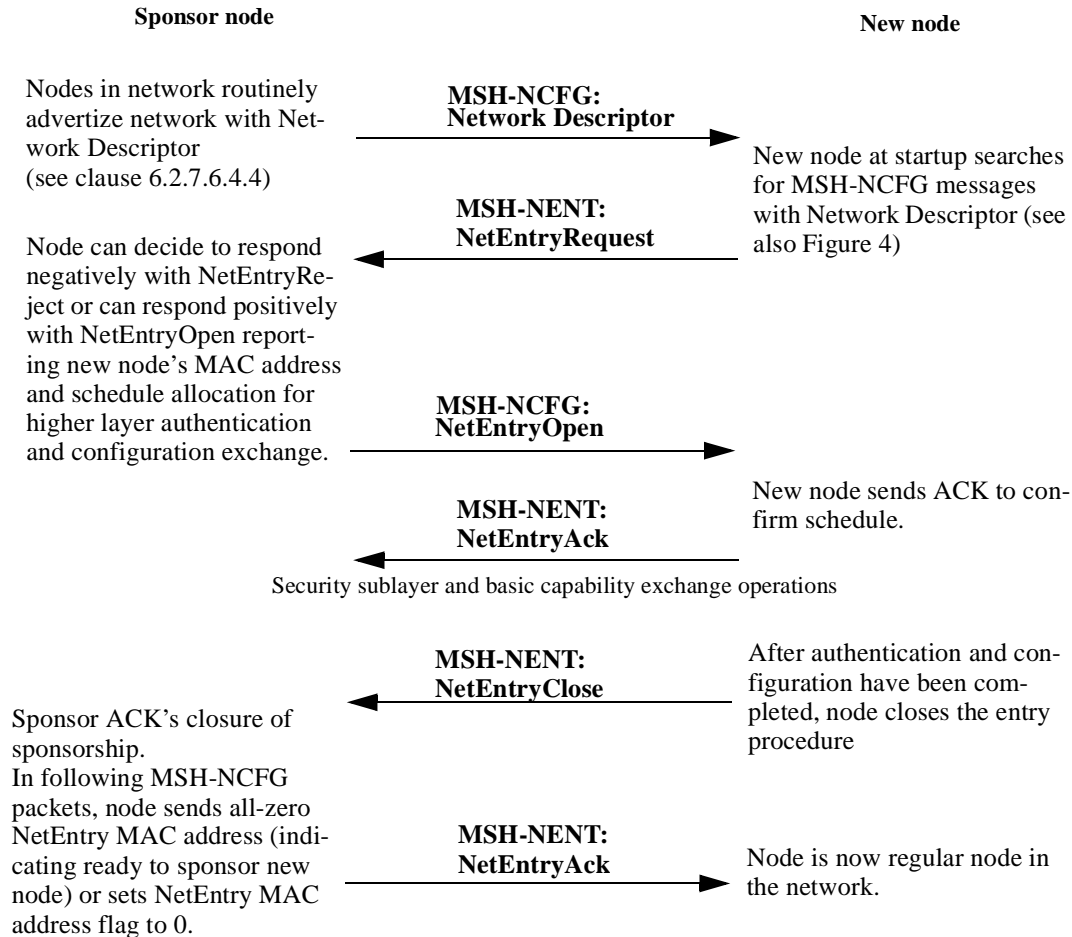


Figure 5—Mesh network synchronization and entry - sponsor node

Figure 6 displays the message transfer sequence during a successful network entry without repetitions or time-outs.



**Figure 6—Successful network Entry message exchange**

#### 6.2.9.13.4 Negotiate Basic Capabilities

In Mesh Mode, the Negotiate Basic Capabilities step of initialization shall be done as described in clause 6.2.9.7. The new node shall act as the SS and the spons node shall act as the BS.

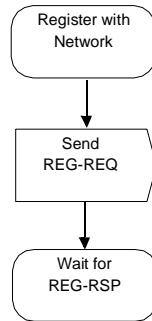
Note that upon successful network entry the other neighboring nodes will learn the capabilities of the new node via the MSH-NCFG message.

#### 6.2.9.13.5 Node Authorization

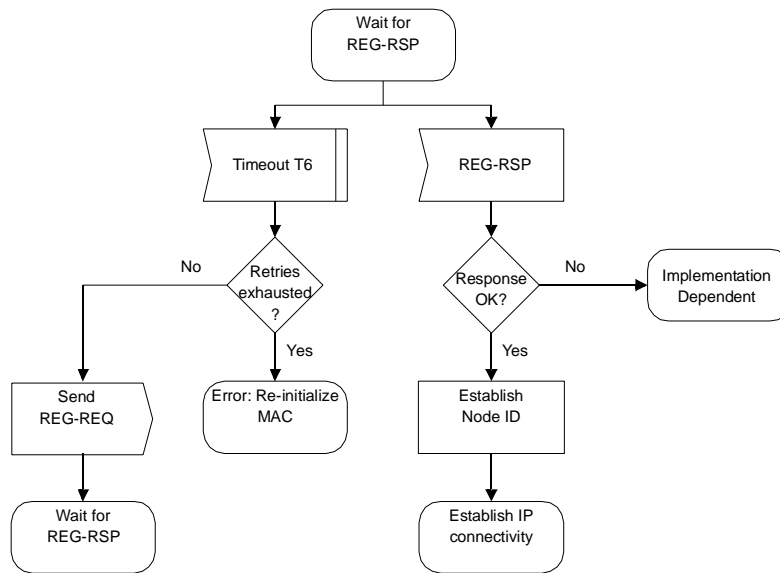
The new node shall perform authorization as described in clause 7.2. The new node shall act as the SS. The sponsor node upon reception of the Authnt Info and Auth Request shall tunnel the messages as described in 6.2.12 to the Authorization Node. The Authorization Node, acting as the BS, shall verify the SS Certificate of the new node and determine whether the new node is authorized to join the Network. Upon receiving tunneled PKM-RSP MAC Messages from the Authorization Node the Sponsor shall forward the messages to the new node.

**6.2.9.13.6 Node registration**

Registration is the process by which a node is assigned its Node ID. The sponsoring node upon reception of the REG-REQ shall tunnel the message as described in 6.2.12 to the Registration Node. Upon receiving tunneled REG-RSP MAC Messages from the Registration Node the Sponsor shall forward the messages to the new node. The new node shall follow the procedure in Figure 7 and Figure 8. The Registration Node shall follow the procedure in Figure 9.

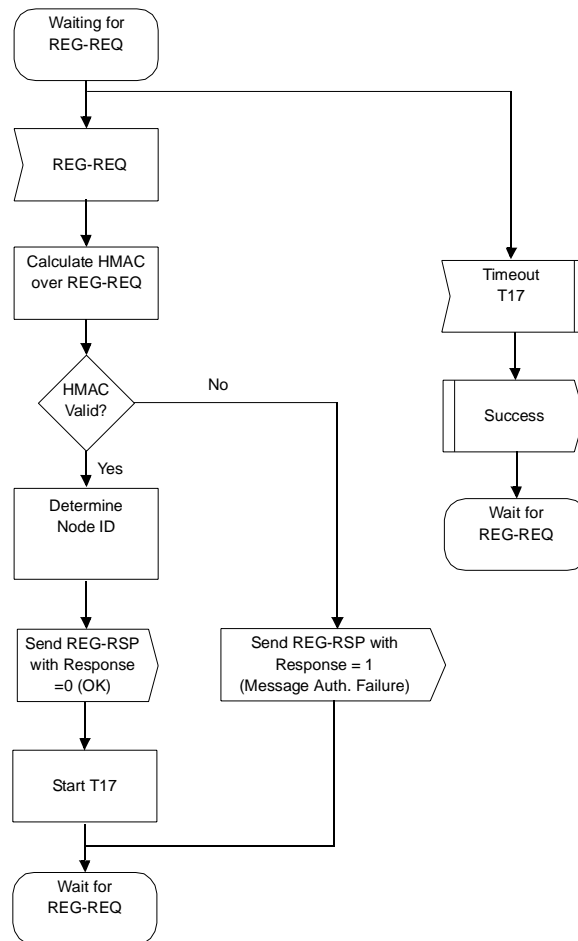


**Figure 7—Registration — Candidate Node**



**Figure 8—Wait for Registration Response — Candidate Node**

1  
2  
3  
4  
5  
6  
7  
8  
9  
10  
11  
12  
13  
14  
15  
16  
17  
18  
19  
20  
21  
22  
23  
24  
25  
26  
27  
28  
29  
30  
31  
32  
33  
34  
35  
36  
37  
38  
39  
40  
41  
42  
43  
44  
45  
46  
47  
48  
49  
50  
51  
52  
53  
54  
55  
56  
57  
58  
59  
60  
61  
62  
63  
64  
65



**Figure 9—Registration — Registration Node**

### 6.2.9.13.7 Establish IP connectivity

The Node shall acquire an IP address using DHCP. The procedure is shown in Table 15 and takes place over the Sponsor Channel.

### 6.2.9.13.8 Establish time of day

The Nodes in a mesh network shall retrieve the time of day using the protocol defined in <ref to IETF RFC 868>. The messages shall be carried over UDP in the Sponsor Channel.

### 6.2.9.13.9 Transfer operational parameters

After successfully acquiring an IP address via DHCP the Node shall download a parameter file using TFTP. The procedure is described in clause 6.2.9.12. The Node shall instead of the Secondary Management connection use the Sponsor Channel for this purpose.

### 6.2.9.13.10 Setup Provisioned Traffic Parameters

To setup the provisioned Traffic Parameters the Node shall send a DSA-REQ to the sponsor. The Sponsoring Node upon reception of the DSA-REQ and DSA-ACK shall tunnel the message as described in 6.2.12 to the Provisioning Node. Upon receiving tunneled REG-RSP MAC Messages from the Provisioning Node the Sponsor shall forward the messages to the Candidate Node.

*page 72, line 49, insert subclause*

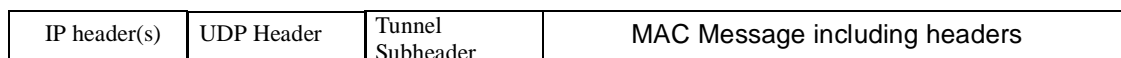
### 6.2.12 MAC Management Message tunneling in Mesh Mode

In Mesh networks during network entry certain MAC Message protocols take place between entities separated by multiple hops. In these cases the Sponsor Node shall relay the MAC Messages from the New Node acting as the SS to the peer performing the duties of the PMP BS. The sponsor shall also relay the messages from the BS entity to the New Node.

The Sponsor shall tunnel the MAC Messages received from the New Node (SS) listed in Table 16 over UDP as shown in Figure 10. to the entity performing the BS part of the protocol. The UDP source and destination port used for tunneled messages shall be equal to 80216\_UDP\_PORT. The sponsor shall also extract the MAC messages from the UDP packets arriving from the BS entity and transmit them over the air to the New Node.

**Table 16—MAC Management Messages tunneled over UDP during network entry**

Message	Action of sponsor	Direction of Message
PKM-REQ:Auth Request	Tunnel	SS to BS
PKM-REQ:Auth Info	Tunnel	SS to BS
PKM-RSP:Auth Reply	Extract	BS to SS
PKM-RSP:Auth Reject	Extract	BS to SS
REG-REQ	Tunnel	SS to BS
REG-RSP	Extract	BS to SS
DSA-REQ	Tunnel	SS to BS
DSA-RSP	Extract	BS to SS
DSA-ACK	Tunnel	SS to BS



**Figure 10—MAC over UDP/IP tunneling**



The format of the Tunnel Subheader is defined in Table 17.

**Table 17—Tunnel Subheader Format**

Syntax	Size	Notes
Tunnel_Subheader(){		
Type	1 byte	Encoding TBD
}		

Also MAC messages may need to be tunneled end to end in cases when the protocol takes place between peers separated by several hops. The packet format in Figure 10 shall be used in these cases with the Tunnel Subheader format defined in Table 17.

**|** *page 72, line 65:*

## **7.2.2 TEK exchange overview**

**|** *Insert immediately after header*

### **7.2.2.1 TEK exchange overview for PMP topology**

**|** *Insert at end of clause*

#### **7.2.2.2 TEK exchange overview for Mesh Mode**

Upon achieving authorization, a Node starts for each Neighbour a separate TEK state machine for each of the SAIDs identified in the Authorization Reply message. Each TEK state machine operating within the Node is responsible for managing the keying material associated with its respective SAID. The Node is responsible for maintaining the TEKs between itself and all nodes it initiates TEK exchange with. Its TEK state machines periodically send Key Request messages to the Neighbours of the node, requesting a refresh of keying material for their respective SAIDs.

The Neighbour to a Key Request with a Key Reply message, containing the BS's active keying material for a specific SAID.

The traffic encryption key (TEK) in the Key Reply is encrypted, using the node's public key found in the SS-Certificate attribute.

Note that at all times the node maintains two active sets of keying material per SAID per neighbour. The lifetimes of the two generations overlap such that each generation becomes active halfway through the life of its predecessor and expires halfway through the life of its successor. A neighbour includes in its Key Replies *both* of an SAID's active generations of keying material.

The Key Reply provides the requesting Node, in addition to the TEK, the remaining lifetime of each of the two sets of keying material. The receiving Node uses these remaining lifetimes to estimate when the Neighbour will invalidate a particular TEK, and therefore when to schedule future Key Requests. The transmit regime between the initiating Node and the Neighbour provides for seamless key transition.

1 | ***Insert subclauses 7.4.1.6 and 7.4.2.7***

2  
3  
4 | **7.4.1.6 Node re-authorization in Mesh Mode during normal operation**

5  
6 | When re-authorizing with the network, the messages shall be sent by the re-authorizing over UDP as shown  
7 | in Figure 10.

8  
9  
10 | **7.4.2.4 TEK usage in Mesh Mode**

11 | For each of its SAIDs, the Neighbour shall transition between active TEKs according to the following rules:

- 12  
13 |     b) At expiration of the older TEK, the Neighbour shall immediately transition to using the newer TEK  
14 |     for encryption.  
15 |     c) The Neighbour that generated the TEK shall use the older of the two active TEKs for encrypting  
16 |     traffic towards the initiator (younger) Node.  
17 |     d) The Neighbour that generated the TEK shall be able to decrypt traffic from each younger Node  
18 |     using either the older or newer TEK.  
19  
20

21 | For each of its authorized SAIDs, the initiator Node :

- 22  
23 |     a) shall use the newer of its two TEKs to encrypt traffic towards its older Neighbours with which it initiated a  
24 |     TEK exchange, and  
25 |     b) shall be able to traffic from the older Neighbour's traffic encrypted with either of the TEKs.  
26  
27  
28  
29

30 | **7.4.2.5 Node usage of the Operator Shared Secret in Mesh Nodes**

31  
32 | Each node shall be capable of maintaining two active Operator Shared Secrets. A Node shall use the Opera-  
33 | tor Shared Secret to calculate a HMAC digest for the Key Request and Key Reply messages when exchang-  
34 | ing TEKs with its neighbouring nodes.  
35  
36

37 | **7.5.3 Calculation of HMAC Digests**

38  
39 | ***Insert after first paragraph:***

40  
41 | In Mesh Mode HMAC digests calculated with the key HMAC\_KEY\_S shall be supported. When calculat-  
42 | ing the digest with this key the HMAC sequence Number in the HMAC tuple shall be equal to the Operator  
43 | Shared Secret Sequence Number.  
44  
45  
46

47 | ***Insert in section 7.5.4.3 (page 223 line 65 in 802.16D5)***

48  
49 | HMAC\_KEY\_S = SHA(H\_PAD\_D|Operator Shared Secret)  
50  
51

52 | ***page 202, line 44, insert subclauses***

53  
54 | **11.3.7 Authorization Node**

55  
56 | The Authorization Node parameter contains the IP address of the Authorization Node.  
57  
58  
59

Type	Length	Value
22	4 or 16	IP Address

### 11.3.8 Registration Node

The Registration Node parameter contains the IP address of the Registration Node.

Type	Length	Value
22	4 or 16	IP Address

### 11.3.9 Provisioning Node

The Provisioning Node parameter contains the IP address of the Provisioning Node.

Type	Length	Value
22	4 or 16	IP Address

### 11.2.14 Cryptographic-Suite

**change Table 136 as shown in Table 18**

**Table 18—Version Attribute Values**

Value	Description
0	<i>reserved</i>
1	3-DES EDE with 128-bit key
<u>2</u>	<u>RSA with 1024 bit key</u>
<del>23</del> –255	<i>reserved</i>

## Mesh system profile changes

*page 208, line 38, insert subclause*

### 12.2 Mesh system profile

The mesh system profile addresses the requirements of a system that is intended to operate in the optional mesh configuration. Basic functionalities are mandatory for a mesh node as they are for a PMP node, except those that are stated as optional below. All the clauses referring to optional mesh mode in the standard shall apply to a mesh-enabled system as mandatory.

For a mesh-enabled system, the messages below and the corresponding functionality are always mandatory to implement:

- MSH-NCFG
- MSH-NENT
- MSH-DSCH
- MSH-CSCH
- MSH-CSCF
- REG-REQ
- REQ-RSP
- DSA-ACK
- DSA-REQ
- DSA-RSP
- PKM-REQ
- PKM-RSP

For a mesh enabled system, the following messages and the corresponding functionality are mandatory/optional whenever they are correspondingly optional/mandatory for a PMP system:

- ARQ-Feedback
- SBC-REQ
- SBC-RSP
- TFTP-CPLT
- TFTP-RSP
- RES-CMD

1 When operating in the mesh mode, the messages below and the corresponding functionality are not used.

2  
3 DL-MAP  
4 DCD  
5 DSC-ACK  
6 DSC-REQ  
7 DSD-RSP  
8 DSX-RVD  
9 UCD  
10 UL-MAP  
11 CLK-CMP  
12 DCC-REQ  
13 DCC-RSP  
14 DBPC-REQ  
15 DBPC-RSP  
16 DREG-CMD  
17 CFS-REQ  
18 CFS-RSP  
19 DRFM  
20 MCA-REQ  
21 MCA-RSP  
22 RNG-REQ  
23 RNG-RSP  
24  
25  
26  
27  
28

29  
30 Generally, the following procedures are different for a mesh node and a P-MP node:

31  
32 Synchronization  
33 Network entry  
34 Scheduling  
35  
36  
37  
38  
39  
40  
41  
42  
43  
44  
45  
46  
47  
48  
49  
50  
51  
52  
53  
54  
55  
56  
57  
58  
59  
60  
61  
62  
63  
64  
65

## Subchannelization in OFDM UL

It seems quite possible to integrate 256-subchannelization support into the current OFDM mode in the upstream as suggested by Alvarion as session #17. It might actually also be worthwhile doing if the overhead does not increase too much (which it doesn't look like, as I'm counting 3 bits per UL-MAP allocation only). However, there are a few issues that need to be carefully fleshed out before any decision can be made.

The main motivation for the proposal is from my end the uncertainty regarding the potential performance problems with granularity. The performance hit largely depends on traffic distribution assumptions, and may or may not be an issue depending on applications etc.

This support naturally needs to be optional, though optional in a way that does not destroy interoperability. I've tried to define the necessary components for the draft below. It should be noted that the option of subchannelization is only defined for regular UL data exchanges, not for network entry, bandwidth requests etc. Hence supporting this option becomes purely a matter for the BS scheduler to take care of and both supporting and non-supporting Ss can peacefully use the same BS.

### 8.3.5.5.2.2.1 UL-MAP Information Element Format

The usage of the subchannel index could be default, or could be present only depending on the indication in the UCD.

**page 157, line 25, change table 208, renaming "offset to "minislot start":**

**Table 208— OFDM UL-MAP information element**

Syntax	Size	Notes
UL-MAP_information_element() {		
<b>CID</b>	16 bits	
<b>UIUC</b>	4 bits	
<b>Minislot start</b>	12 bits	
if (BS supports subchannelization) {	12 bits	
<b>Subchannel Index</b>	3 bits	0x0 = use all subchannels (default) 0x1 = use subchannel 0 0x2 = use subchannel 1 0x3 = use subchannel 2 0x4 = use subchannel 3 0x5 = use subchannel 0 and 1 0x6 = use subchannel 2 and 3 0x7 = Reserved
<b>Reserved</b>	1 bit	
}		
<b>Padding nibble</b>	4 bits	Pad till byte boundar
}		

### Minislot Start

The start time of the burst relative to the Allocation Start Time given in the UL-MAP message. The end time is indicated by the Minislot Start of the next burst. The end of the last allocated burst is indicated by allocating a NULL burst (CID = 0 and UIUC = 14) with zero duration. The time instants indicated by the offsets are the transmission times of the first symbol of the burst including preamble.

### 8.3.5.5.3 OFDM Symbol Parameters

*page 159, line 35 replace table 212*

**Table 209—OFDM Symbol Parameters**

Parameter	Value	
$N_{FFT}$	256	
$N_{used}$	200	
$F_s/BW$	7/6	
Guard Carriers	28 left: -128,...,-101	27 right: 101,...,127
BasicConstantLocationPilots	{-84,-60,-36,-12,12,36,60,84}	
Subchannel number: Allocated carriers	0: {-100,...,-51} 1: {-50,...,-1} 2: {1,...,50} 3: {51,...,100}	

#### 8.3.5.5.4.2.1 Concatenated Reed-Solomon and Convolutional coding

The main problem of the subchannelization is the FEC. Especially for the lower modulation orders in one or two subchannels, the RS-CC combination will fall apart. Concatenating codes over subchannels in multiple symbols really isn't an answer, because it results in the same granularity problem we started out with (I would oppose this whole subchannelization thing if that is considered the answer.) As such, I don't see much other options than to bypass the RS in these cases, and use CC only. For one and two subchannels of 64QAM, it's probably possible to find suitable RS-CC combinations. Obviously the Turbo codes would need to be adjusted also.

*page 141, line 5, add:*

If in the UL, if the allocation spans less than the whole OFDM symbol (i.e. when subchannelization is used), termination shall occur after each 4 subchannel blocks (counting subchannels within the same OFDM symbol first), or at the end of the allocation if the (remainder of the) allocation is less than 4 subchannel blocks.

*page 160, line 27, replace table 213 and the sentence above it:*

All are mandatory, except those defined for 64QAM modulation and those for less than 4 subchannels, which are mandatory only if the 64QAM modulation and subchannelization are implemented respectively.

**Table 213—Mandatory Channel Coding per Modulation**

Modulation	Subchannels	Uncoded Block Size (Bytes)	Coded Block Size (bytes)	Overall Coding Rate	RS Code	CC Code Rate
QPSK	1	6	12	1/2	None	1/2
QPSK	1	8	12	3/4	None	2/3
QPSK 16QAM	2 1	12	24	1/2	None	1/2
QPSK	2	16	24	3/4	None	2/3
16QAM	1	18	24	3/4	None	3/4
64QAM	1	24	36	2/3		
64QAM	1	27	36	3/4		
QPSK 16QAM	4 2	24	48	1/2	(32,24,4)	2/3
QPSK 16QAM	4 2	36	48	3/4	(40,36,2)	5/6
64QAM	2	48	72	2/3		
64QAM	2	54	72	3/4		
16QAM	4	48	96	1/2	(64,48,8)	2/3
16QAM	4	72	96	3/4	(80,72,4)	5/6
64QAM	4	96	144	2/3	(108,96,6)	3/4
64QAM	4	108	144	3/4	(120,108,6)	5/6

#### 8.3.5.5.4.3 Interleaving

The interleaving should be fine, since it can easily be changed to define NCBPS not as the coded bits per OFDM symbol, but as coded bits per subchannel allocation, depending on whether 1, 2 or 4 subchannels are allocated.

**page 161, 32, replace first sentence with:**

All encoded data bits shall be interleaved by a block interleaver with a block size corresponding to the number of coded bits allocated per OFDM symbol,  $N_{CBPS}$  (i.e.  $N_{CBPS}$  varies depending on modulation, coding rate and the number of subchannels allocated in the OFDM symbol).

#### 8.3.5.5.6 Preamble structure

**page 164, 29, insert:**

If in the UL, if the allocation spans less than the whole OFDM symbol (i.e. when subchannelization is used), the preamble carriers that do not fall within the subchannels allocated shall not be transmitted.



### 11.1.1.1 UCD channel encoding

It is possible to indicate whether the BS supports this uplink subchannelization in the UCD. To do this efficiently, I'd suggest tagging it onto the FFT size. A value of 3 could indicate 256-FFT with UL subchannelization support. Note that this is strictly needed, as SSs need to know how to read the UL-MAP.

**page 196, line 31, change FFT size:**

**Table 214—**

Name	Type (1 Byte)	Length	Value (variable length)	PHY scope
FFT size	12	1	0=FFT-256, 1=FFT-2048, 2=FFT-4096 4-255 Reserved	OFDM, OFDMA, OFDMA2
			3=FFT-256 with subchannelization support	OFDM
			3=Reserved	OFDMA, OFDMA2

### 11.1.4.6 Bandwidth allocation support

**change page 204, line 4**

Type	Length	Value	Scope
5.15	1	bit #0=0: Grant per Connection bit #0=1: Grant per Subscriber Station (SS) bit #1=0: Half-Duplex bit #1=1: Full-Duplex <u>bit #2=0: Not capable of focused contention</u> <u>bit #2=1: Capable of focused contention</u> <u>bit #3=0: No OFDM subchannelization support</u> <u>bit #3=1: OFDM subchannelization support</u> bit # <del>2</del> <u>4</u> -7: reserved; shall be set to zero	SBC-REQ (see 6.2.2.3.23) SBC-RSP (see 6.2.2.3.24)

## License-exempt channelization

### 8.3.5.8.1.1 Channelization

*page 188, line 8, replace equation and following sentence with:*

$$\text{Channel center frequency} = 5252.5 + 2.5 n_{\text{ch}} \text{ (MHz)}$$

where  $n_{\text{ch}} = 0,1,\dots,255$ . This definition provides a 8-bit unique numbering system of all channels with 2.5 MHz spacing from 5.25 GHz to 5.89 GHz to provide flexibility to define channelization sets for all current and future regulatory domains.

*page 188, line 53: Change allocations for CEPT band C (in accordance with RA UK consultation) and renumber*

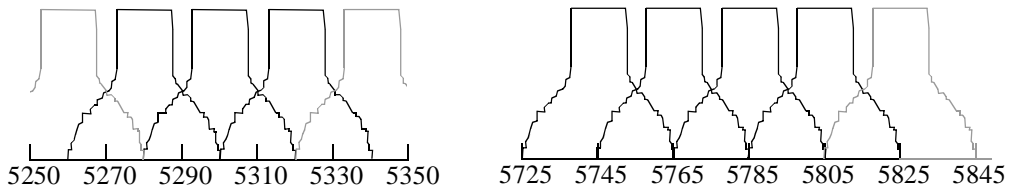
**Table 215—Channelizations**

Regulatory domain	Band (GHz)	Channelization (MHz)		
		20	10	(5)
USA	U-NII middle 5.25 -5.35	(3), 11, 19, 27, (35)	(1), 5, 9, 13, 17, 21, 25, 29, 33, (37)	(2), (4), (6), (8), (10), (12), (14), (16), (18), (20), (22), (24), (26), (28), (30), (32), (34), (36), (38)
	U-NII upper 5.725-5.825	197, 205, 213, 221, 229 <sup>a</sup>	(191), 195, 199, 203, 207, 211, 215, 219, 223, 227 <sup>a</sup> , 231 <sup>a</sup>	(192), (194), (196), (198), (200), (202), (204), (206), (208), (210), (212), (214), (216), (218), (220), (222), (224), (226) <sup>a</sup> , (228) <sup>a</sup> , (230) <sup>a</sup> , (232) <sup>a</sup>
Europe	CEPT band B <sup>b</sup> 5.47-5.725	99, 107, 115, 123, 131, 139, 147, 155, 163, 171	97, 101, 105, 109, 113, 117, 121, 125, 129, 133, 137, 141, 145, 149, 153, 157, 161, 165, 169, 173	(96), (98), (100), (102), (104), (106), (108), (110), (112), (114), (116), (118), (120), (122), (124), (126), (128), (130), (132), (134), (136), (138), (140), (142), (144), (146), (148), (150), (152), (154), (156), (158), (160), (162), (164), (166), (168), (170), (172), (174)
	CEPT band C <sup>b</sup> 5.725-5.875	195, 203, 211, 219, 227, 235	193, 197, 201, 205, 209, 213, 217, 221, 225, 229, 233, 237	(192), (194), (196), (198), (200), (202), (204), (206), (208), (210), (212), (214), (216), (218), (220), (222), (224), (226), (228), (230), (232), (234), (236), (238)

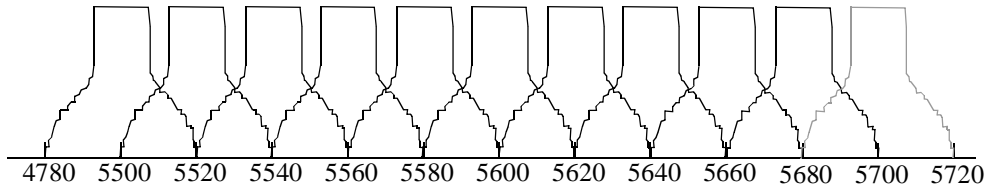
<sup>a</sup>Pending FCC action on docket ET 99-231

<sup>b</sup>Current applicable regulations do not allow this standard to be operated in the indicated band.

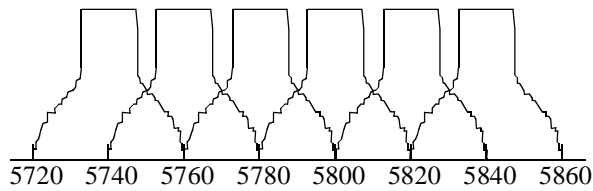
1 | **page 189, line 19, replace figure:**



U-NII middle and upper band



CEPT, 5GHz, band B



CEPT, 5GHz, band C

**Figure 231—Channelization, 20 MHz**

2  
3  
4  
5  
6  
7  
8  
9  
10  
11  
12  
13  
14  
15  
16  
17  
18  
19  
20  
21  
22  
23  
24  
25  
26  
27  
28  
29  
30  
31  
32  
33  
34  
35  
36  
37  
38  
39  
40  
41  
42  
43  
44  
45  
46  
47  
48  
49  
50  
51  
52  
53  
54  
55  
56  
57  
58  
59  
60  
61  
62  
63  
64  
65

1  
2  
3  
4  
5  
6  
7  
8  
9  
10  
11  
12  
13  
14  
15  
16  
17  
18  
19  
20  
21  
22  
23  
24  
25  
26  
27  
28  
29  
30  
31  
32  
33  
34  
35  
36  
37  
38  
39  
40  
41  
42  
43  
44  
45  
46  
47  
48  
49  
50  
51  
52  
53  
54  
55  
56  
57  
58  
59  
60  
61  
62  
63  
64  
65