

Project	IEEE 802.16 Broadband Wireless Access Working Group < http://ieee802.org/16 >	
Title	Changes on Sleep Mode SDLs and MSCs	
Date Submitted	2004-01-15	
Source(s)	Chulsik Yoon, Jaeheung Kim, Kunmin Yeo ETRI 161 Gajeong-Dong, Yuseong-Gu, Daejeon, Korea	Voice: +82-42-860-6826 Fax: +82-42-860-6732 mailto: csyoon@etri.re.kr
Re:	This is a response to a Call for Comments IEEE 802.16e-03/58 on IEEE 802.16e-03/07r5	
Abstract	This document contains suggestions to change the SDLs and MSCs reflecting working groups agreements on the Sleep Mode operation.	
Purpose	The document is submitted for review by 802.16e Working Group members.	
Notice	This document has been prepared to assist IEEE 802.16. It is offered as a basis for discussion and is not binding on the contributing individual(s) or organization(s). The material in this document is subject to change in form and content after further study. The contributor(s) reserve(s) the right to add, amend or withdraw material contained herein.	
Release	The contributor grants a free, irrevocable license to the IEEE to incorporate material contained in this contribution, and any modifications thereof, in the creation of an IEEE Standards publication; to copyright in the IEEE's name any IEEE Standards publication even though it may include portions of this contribution; and at the IEEE's sole discretion to permit others to reproduce in whole or in part the resulting IEEE Standards publication. The contributor also acknowledges and accepts that this contribution may be made public by IEEE 802.16.	
Patent Policy and Procedures	The contributor is familiar with the IEEE 802.16 Patent Policy and Procedures < http://ieee802.org/16/ipr/patents/policy.html >, including the statement "IEEE standards may include the known use of patent(s), including patent applications, provided the IEEE receives assurance from the patent holder or applicant with respect to patents essential for compliance with both mandatory and optional portions of the standard." Early disclosure to the Working Group of patent information that might be relevant to the standard is essential to reduce the possibility for delays in the development process and increase the likelihood that the draft publication will be approved for publication. Please notify the Chair < mailto:chair@wirelessman.org > as early as possible, in written or electronic form, if patented technology (or technology under patent application) might be incorporated into a draft standard being developed within the IEEE 802.16 Working Group. The Chair will disclose this notification via the IEEE 802.16 web site < http://ieee802.org/16/ipr/patents/notices >.	

Changes on Sleep Mode SDLs and MSCs

Chulsik Yoon, Jaeheung Kim, Kunmin Yeo

ETRI

1. Background

Due to the working group's agreement on the sleep mode operation, the SDL diagrams and MSCs in the Annex should be changed appropriately. We propose changes on SDL diagrams and MSCs reflecting the comment resolutions of the last meeting and TGe baseline text IEEE 802.16e-03/07r5.

2. Proposed changes on Sleep Mode operation SDLs and MSCs in IEEE 802.16e-03/07r5

[Replace the Figures to following SDLs and MSCs]

6.4.16 Sleep-mode for mobility-supporting SS

[Replace Figure 108h to the following:]

[From:]

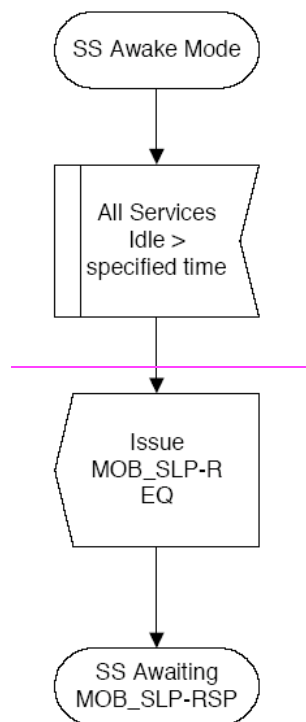

Figure 108h—SS Awaiting Sleep Response SDL Diagram

[To:]

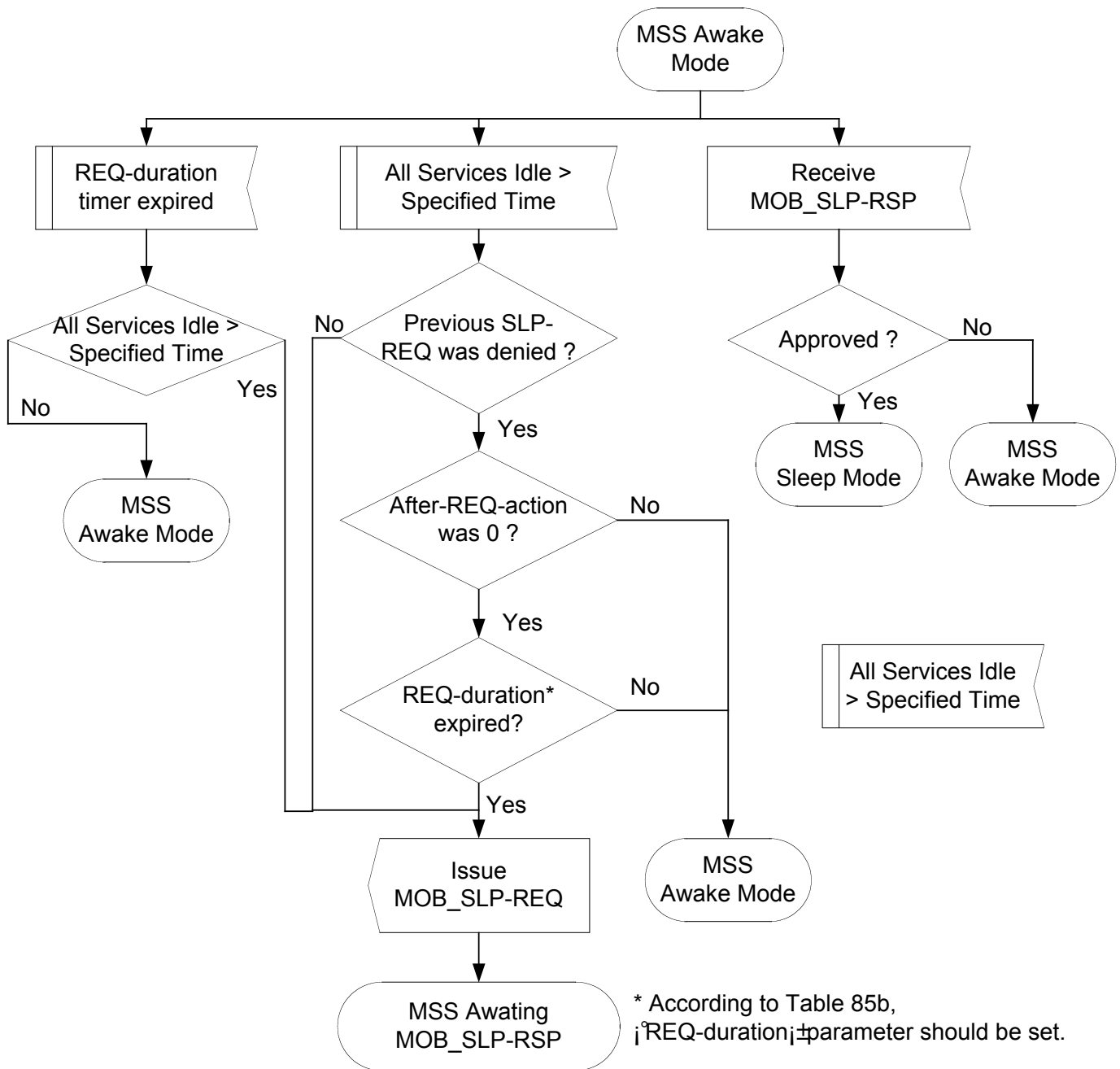

Figure 108h – MSS Awake Mode SDL Diagram

[Replace Figure 108i to the following:]

[From:]

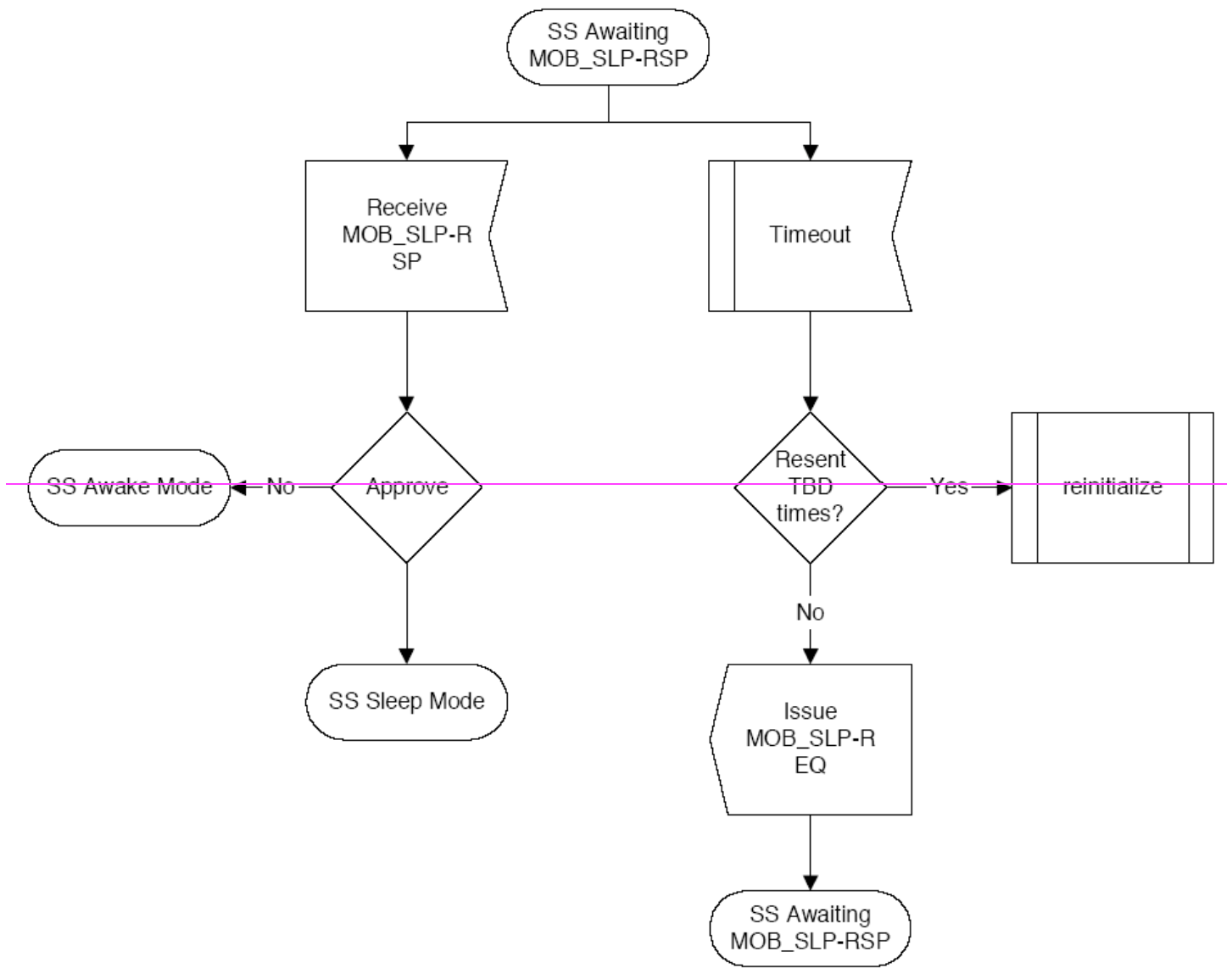

Figure 108i—SS Sleep Mode SDL Diagram

[To:]

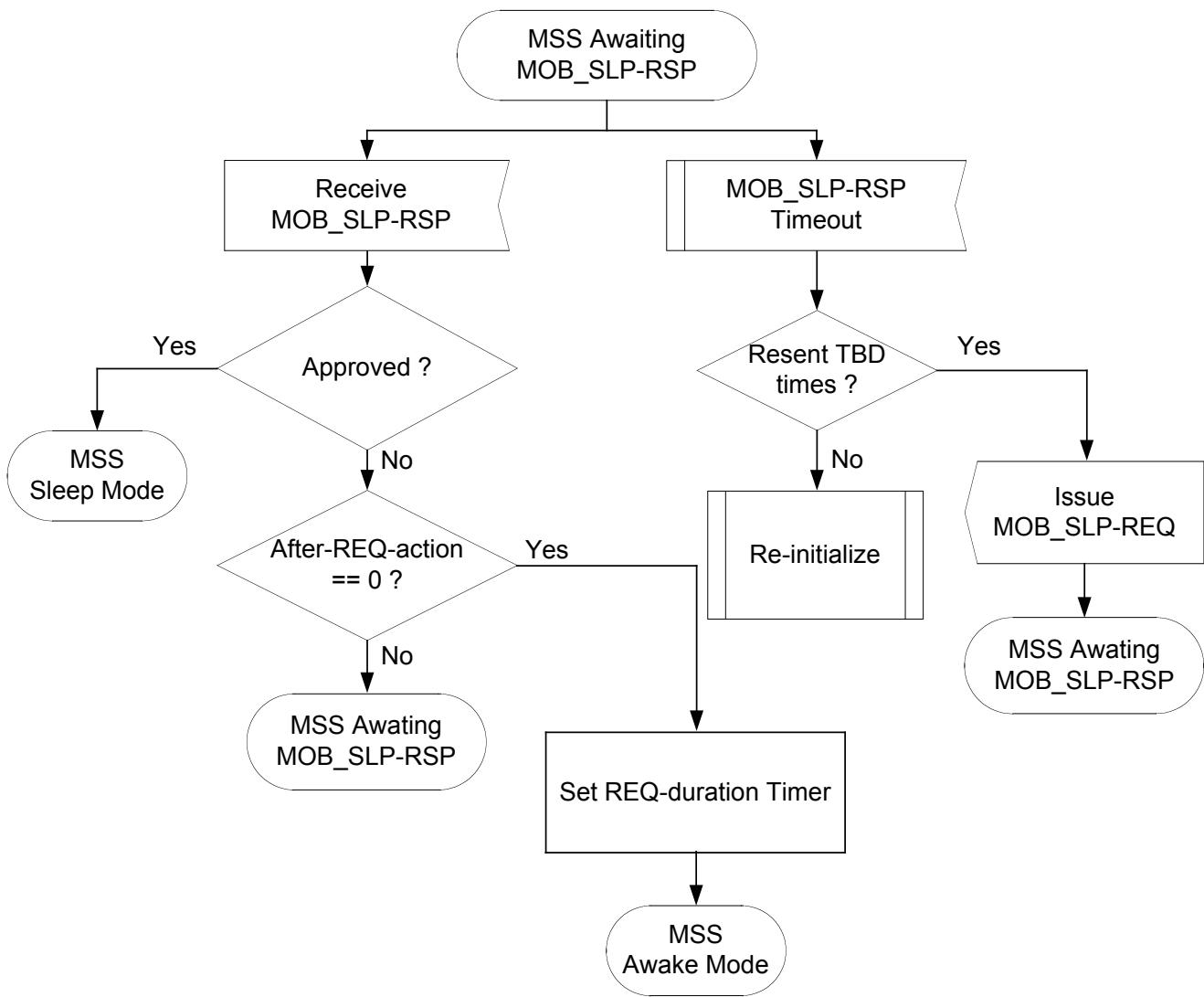

Figure 108i – MSS Awaiting Sleep Response SDL Diagram

[Replace Figure 108j to the following:]
[From:]

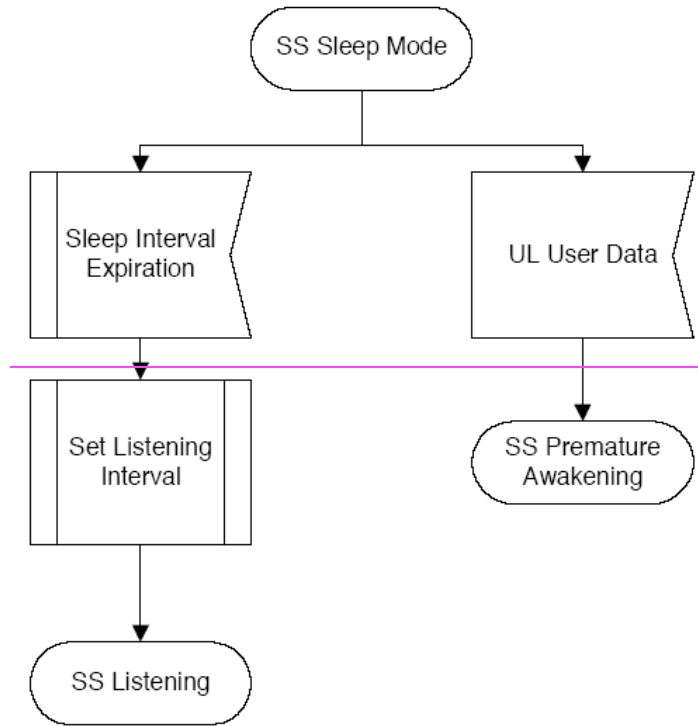

Figure 108j—SS Await Poll SDL Diagram

[To:]

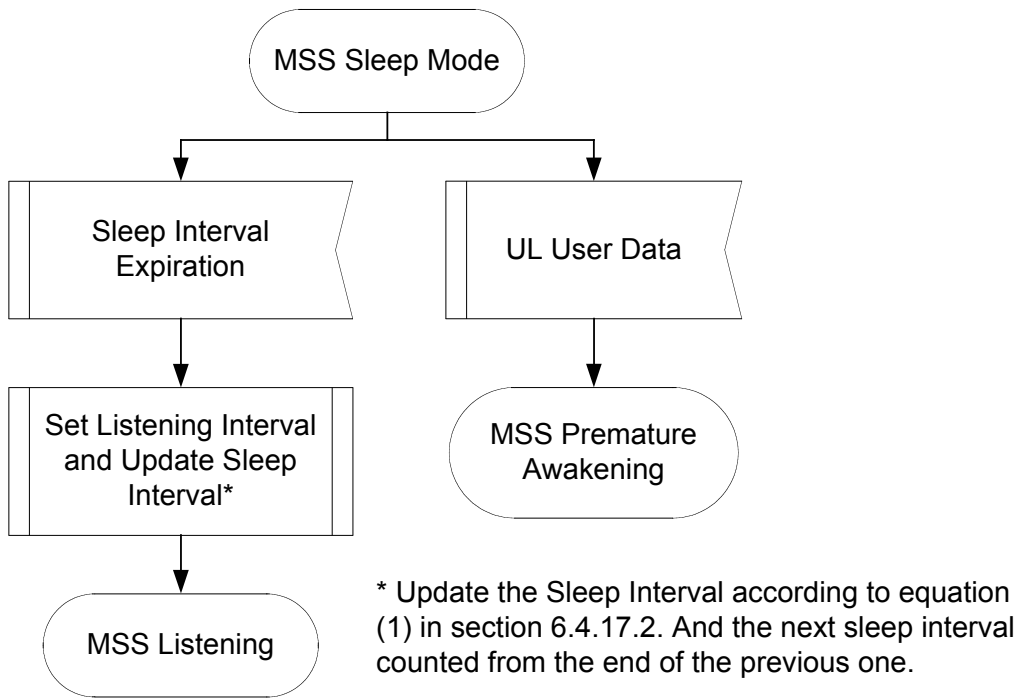

Figure 108j – Typical MSS Sleep Mode SDL Diagram

[Replace Figure 106d to the following:]
[From:]

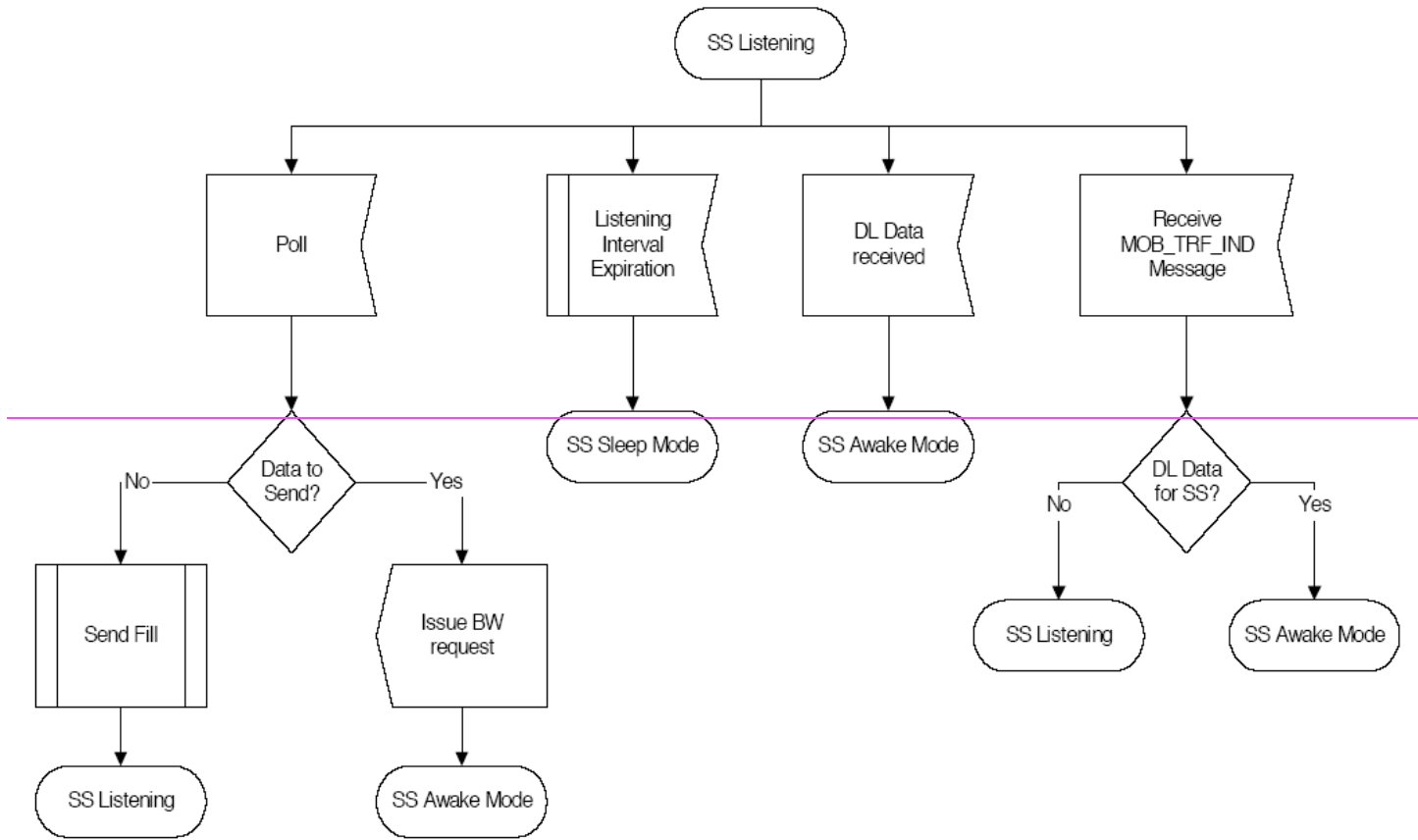

Figure-108k—SS Listening SDL Diagram

[To:]

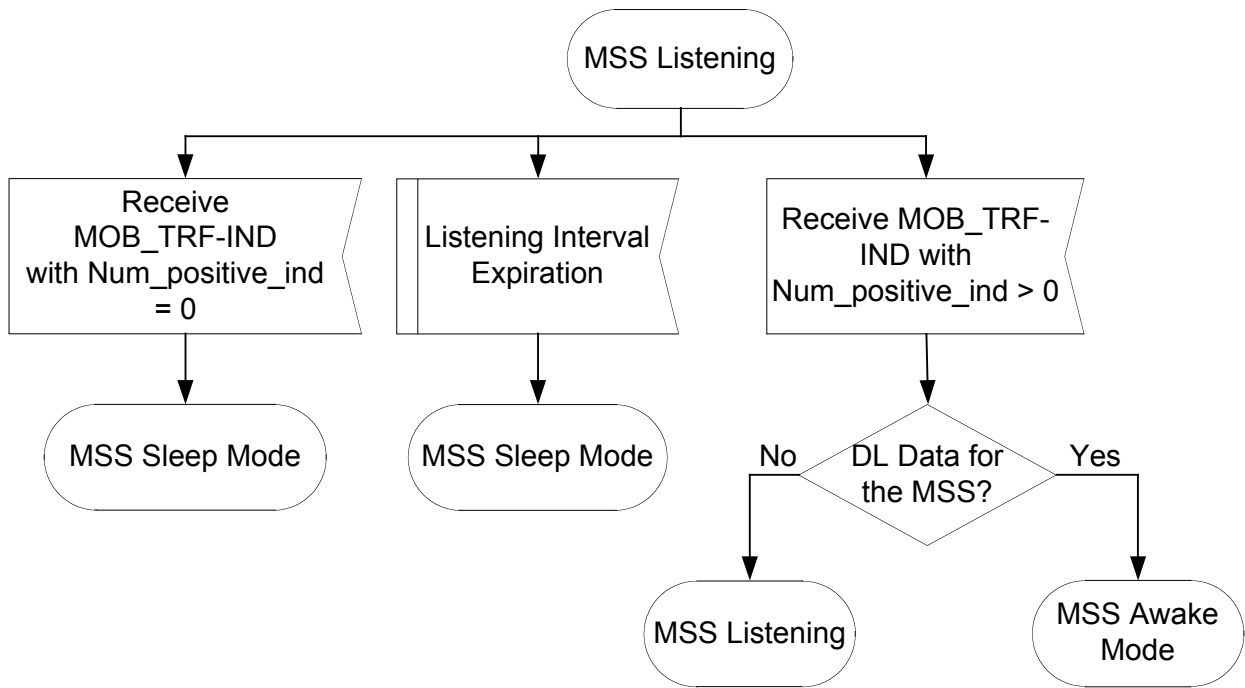

Figure 108k – Typical MSS Listening SDL Diagram

[Replace Figure 108l to the following:]
[From:]

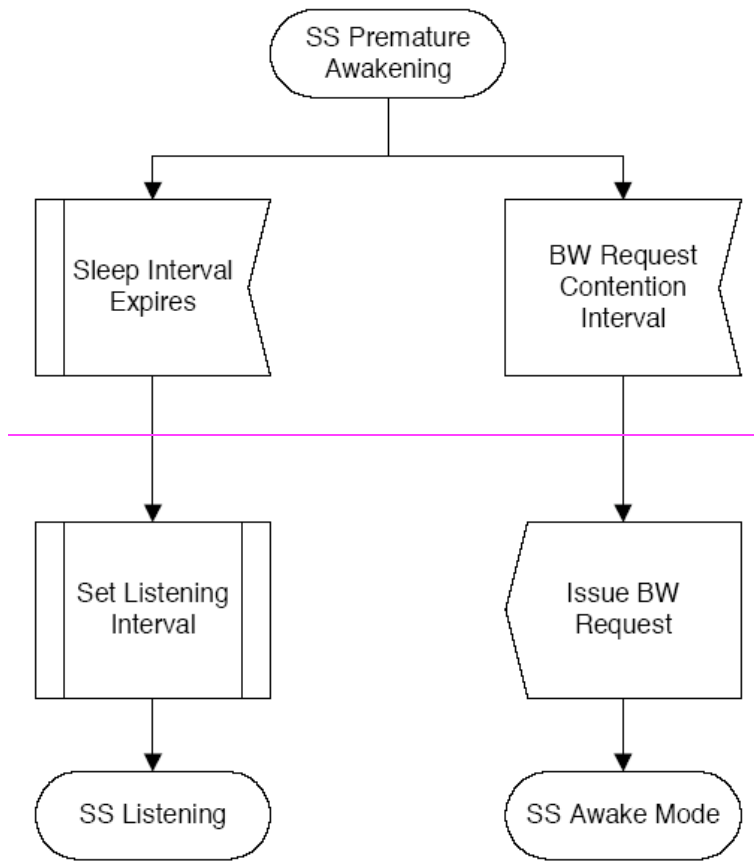

Figure 108l—SS Premature Awakening SDL Diagram

[To:]

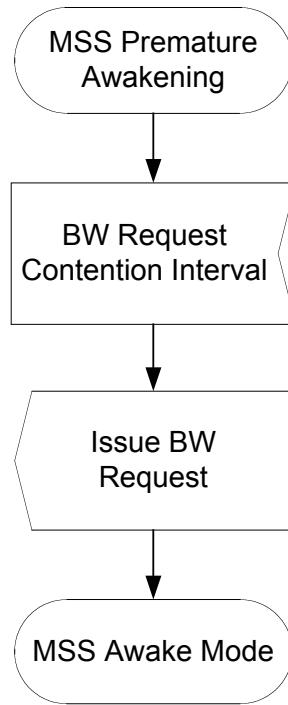

Figure 108I – MSS Premature Awakening SDL Diagram

[Replace Figure 108m to the following:]
[From:]

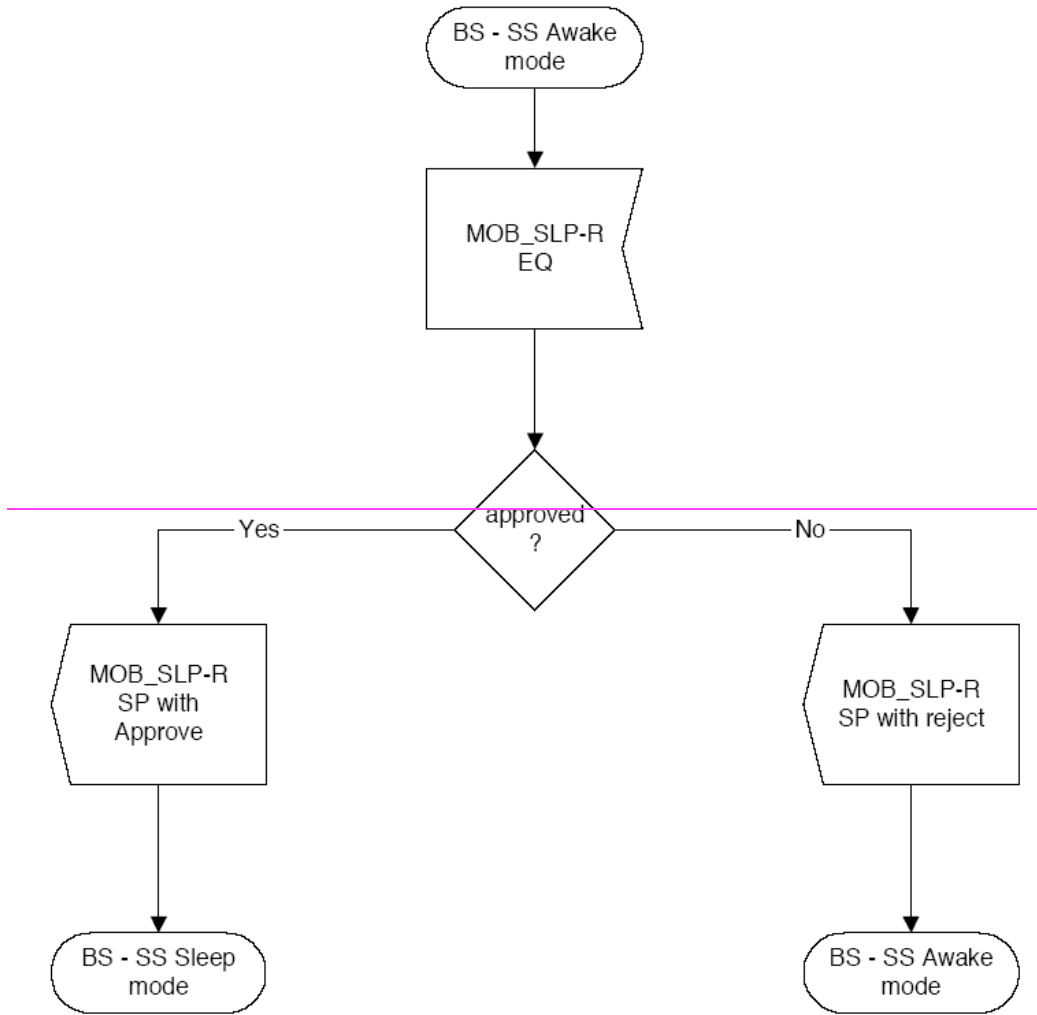

Figure 108m—BS-SS Awake Mode SDL Diagram

[To:]

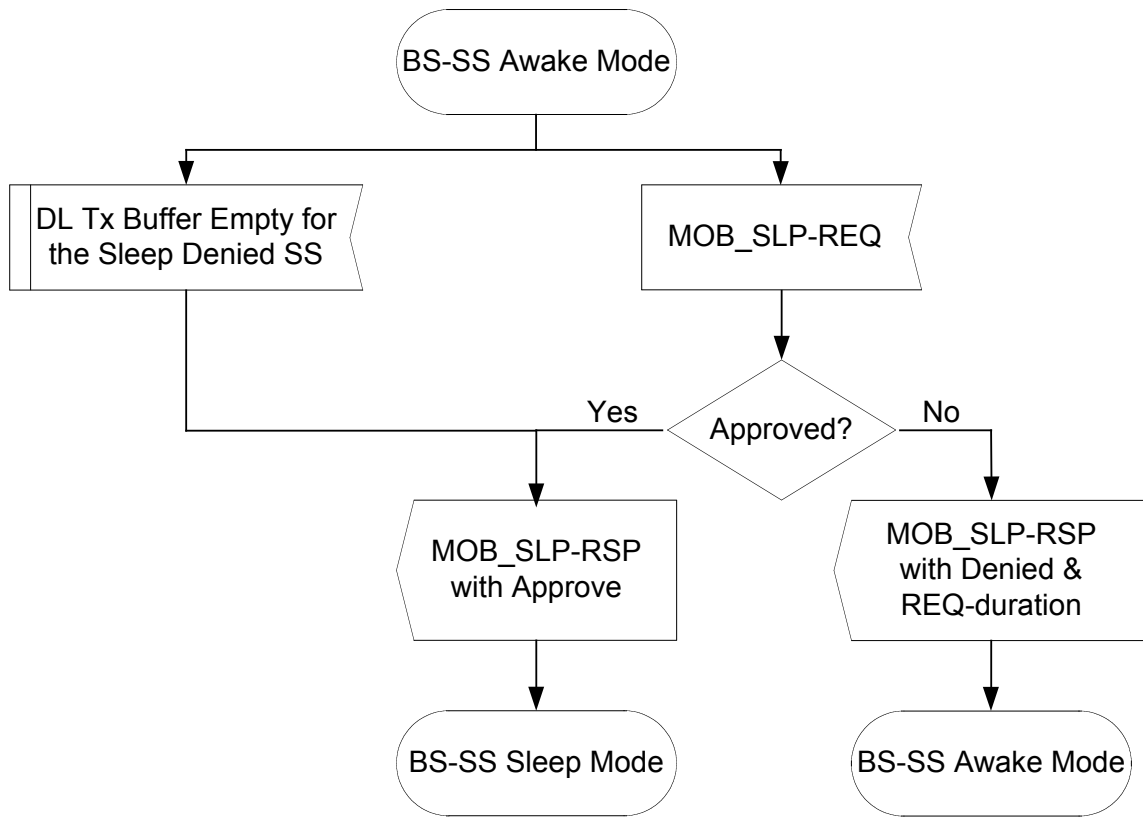

Figure 108m – MSS Premature Awakening SDL Diagram

[Replace Figure 108n to the following:]
[From:]

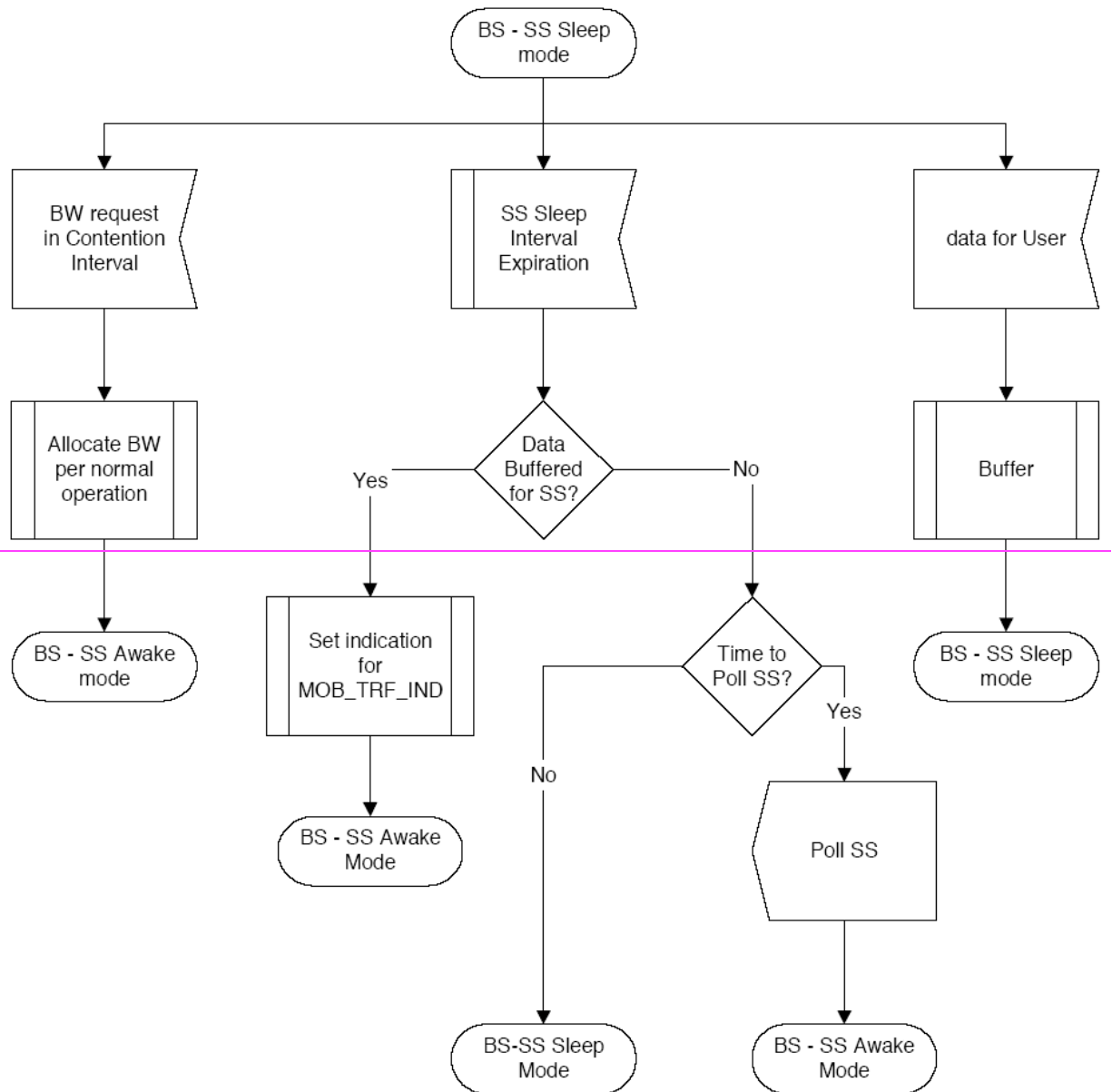

Figure 108n—BS-SS Sleep Mode SDL Diagram

[To:]

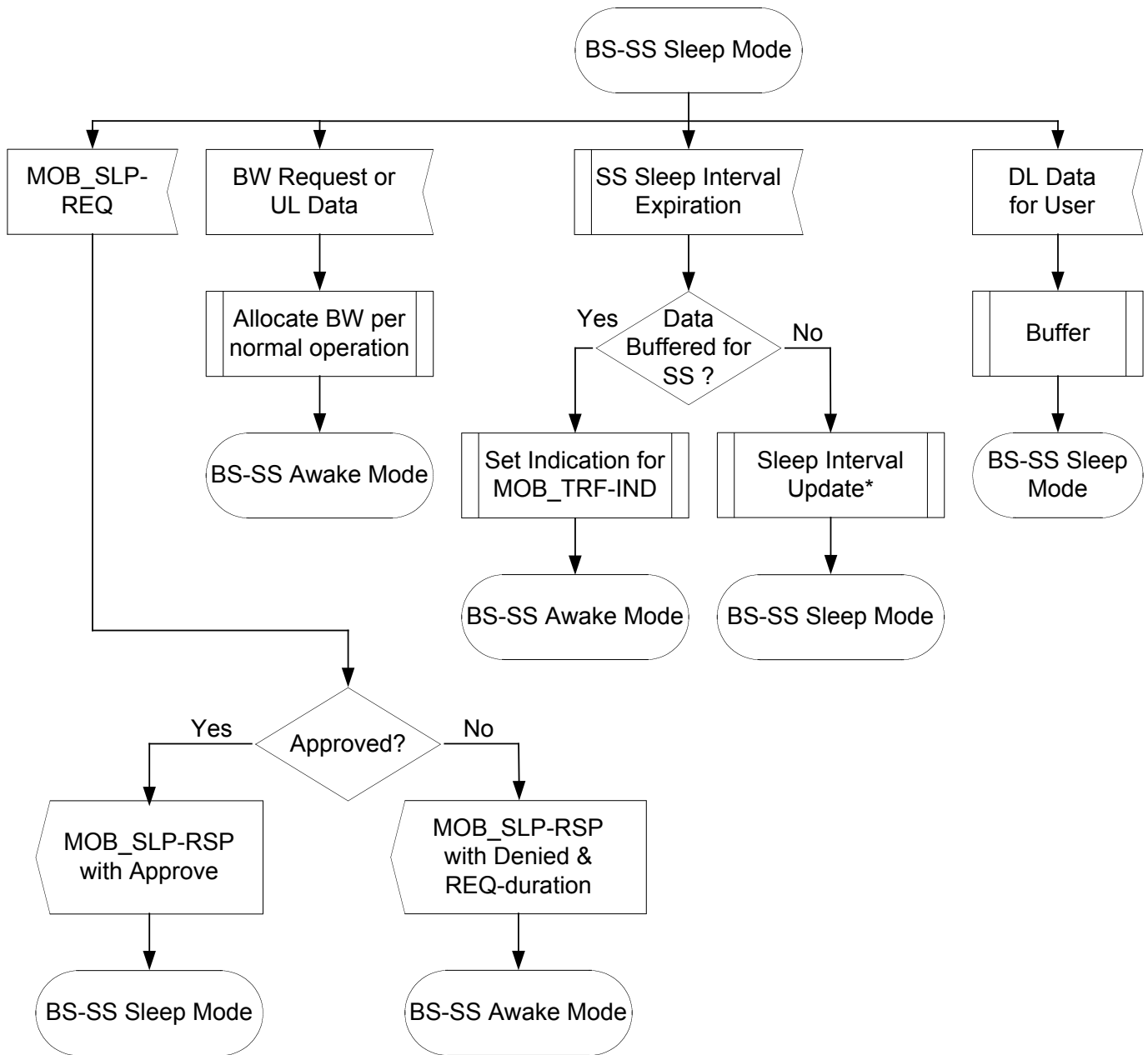
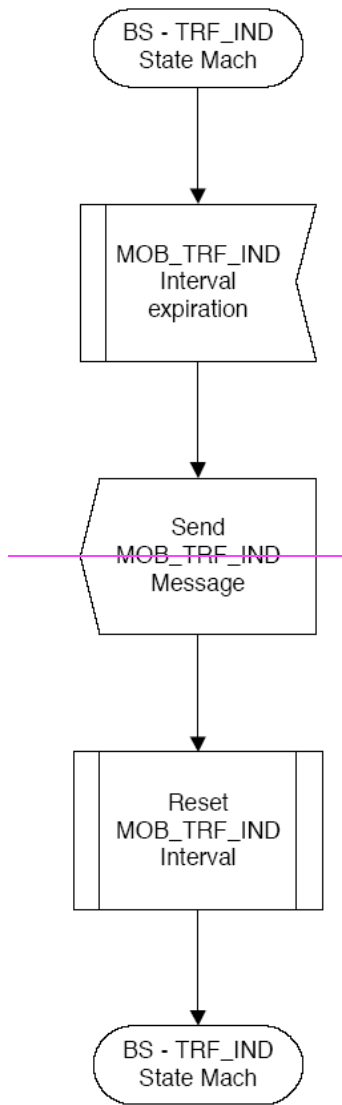

Figure 108n – BS-SS Sleep Mode SDL Diagram

[Delete Figure 108o:]



~~Figure 108n - BS-SS Sleep Mode SDL Diagram~~

[Replace Annex D.2 Figure D.11 to the following:]
 [From:]

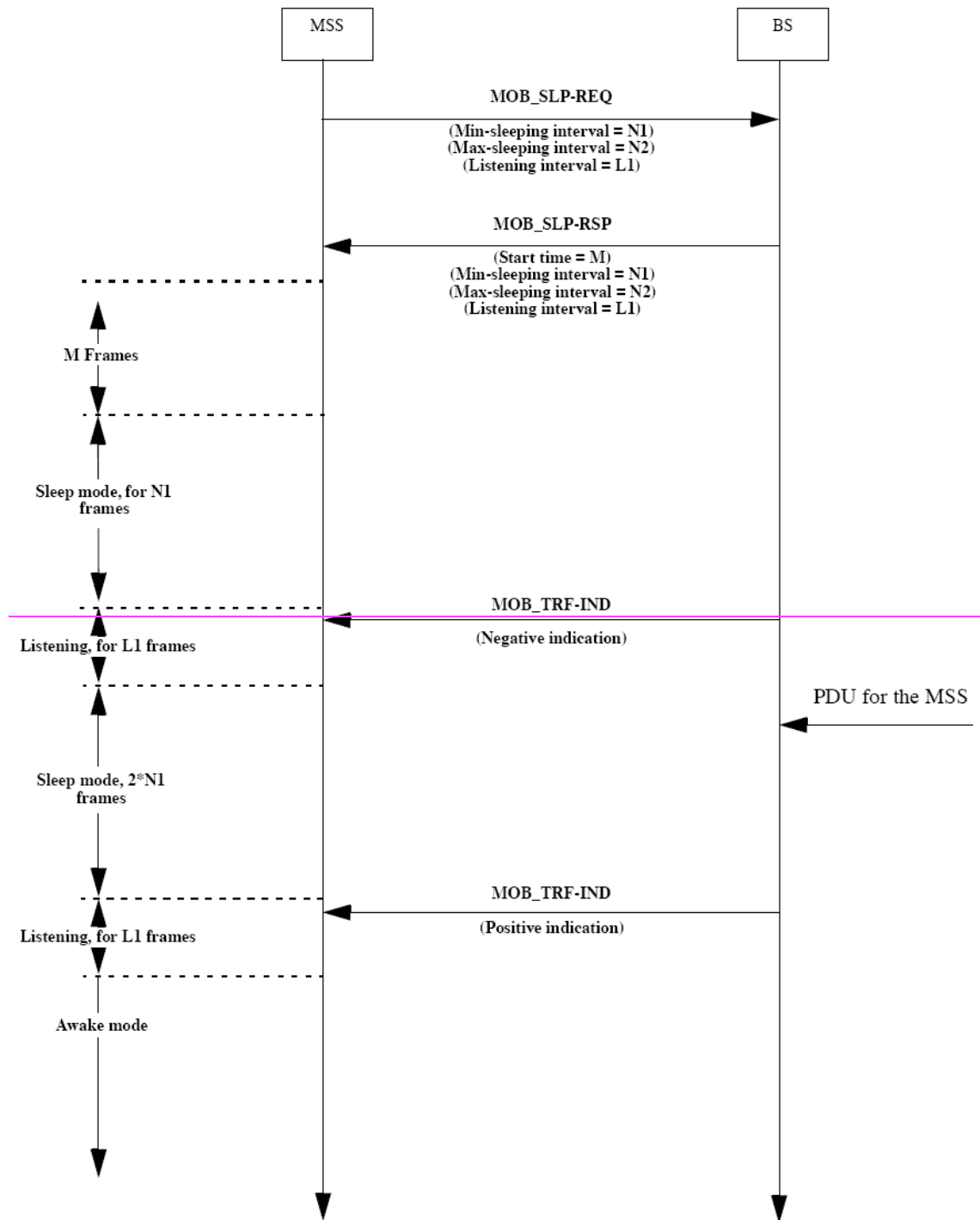

Figure D.11—Example of periodic scanning during Handover process SDL Diagram

[To:]

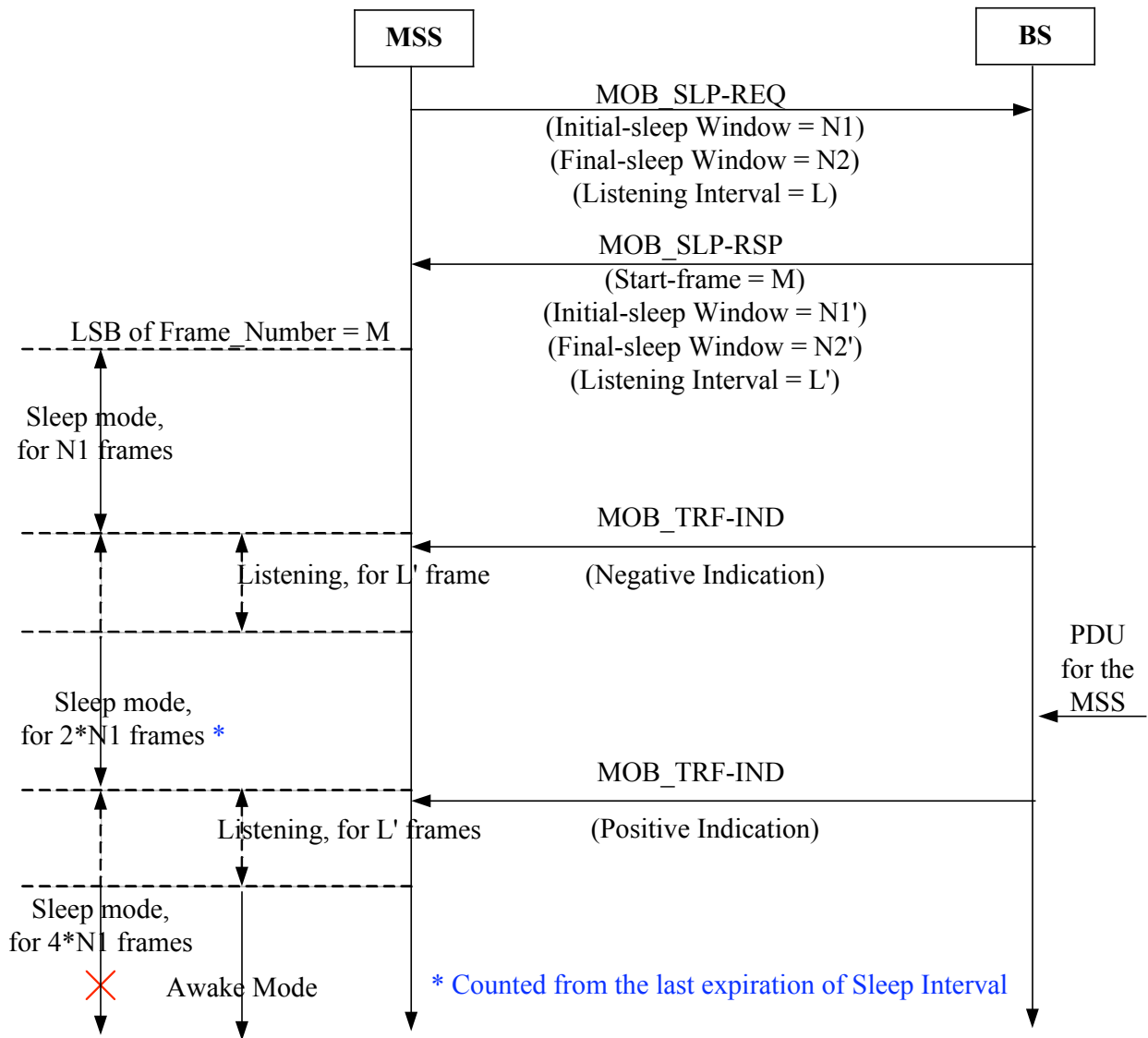

Figure D.11 – Sleep Mode – MSS initiated

[Replace Annex D.2 Figure D.12 to the following:]
[From:]

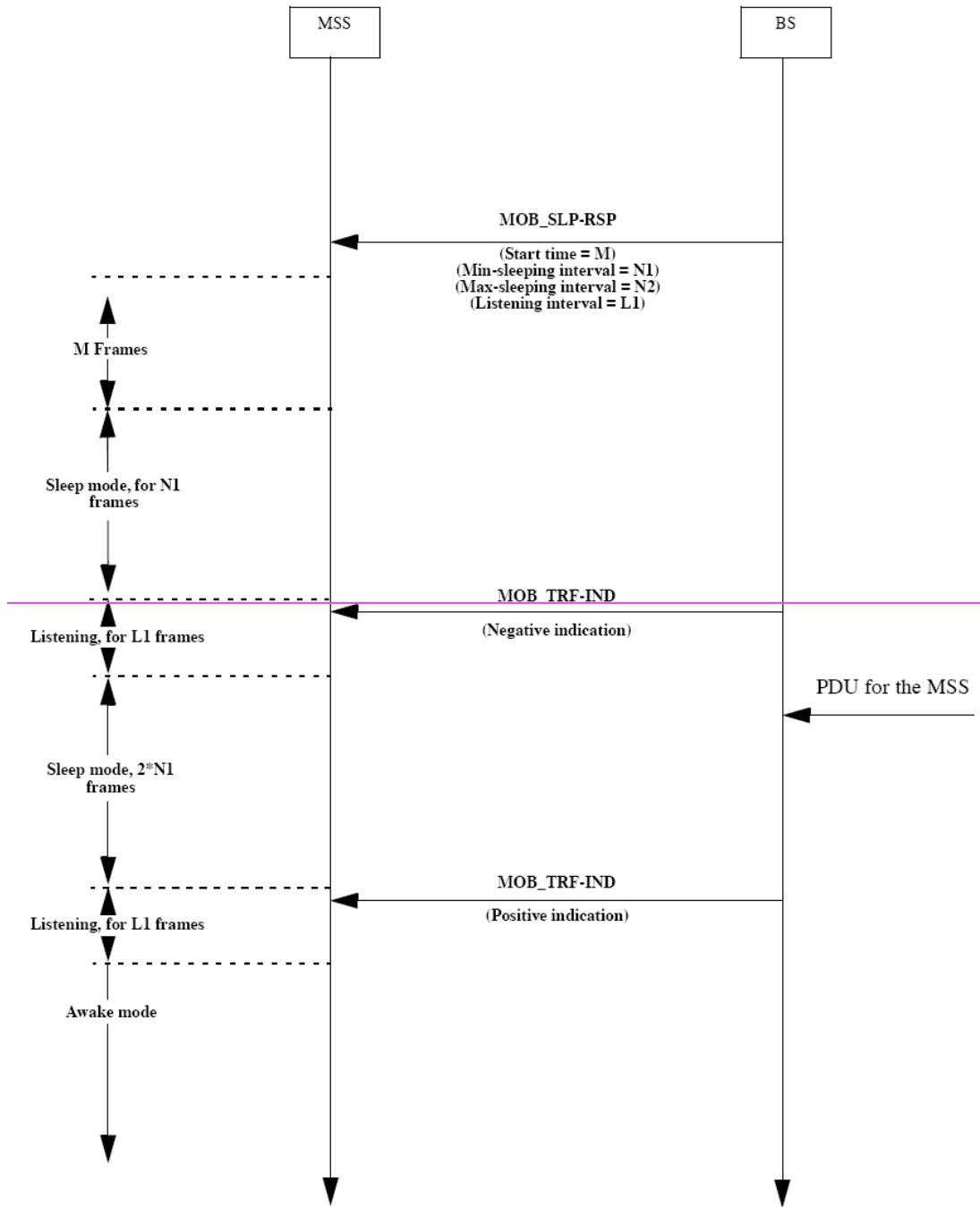

Figure D.12 Sleep Mode, BS-initiated

[To:]

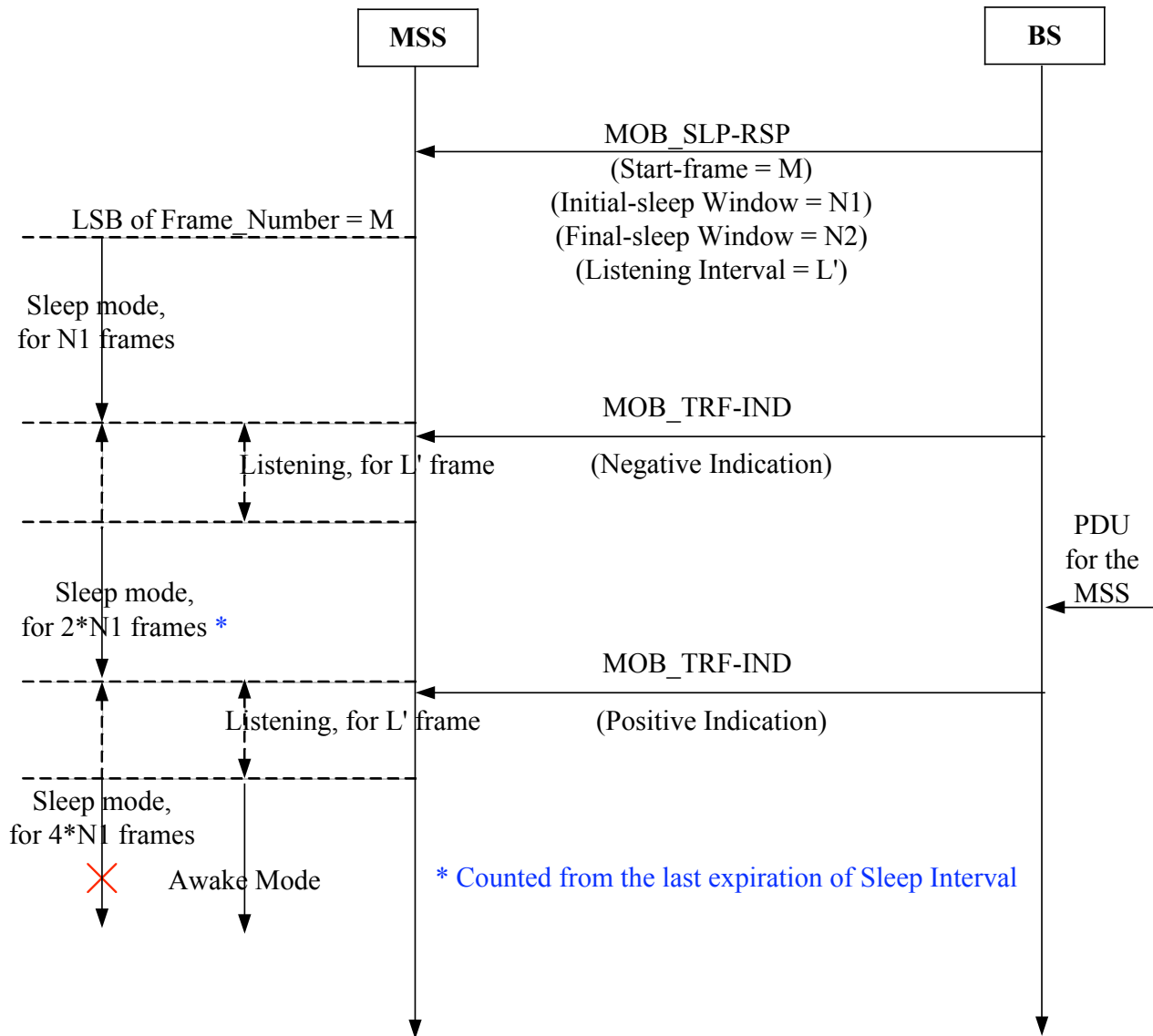

Figure D.12 – Sleep Mode – BS initiated

[Replace Annex D.2 Figure D.13 to the following:]
 [From:]

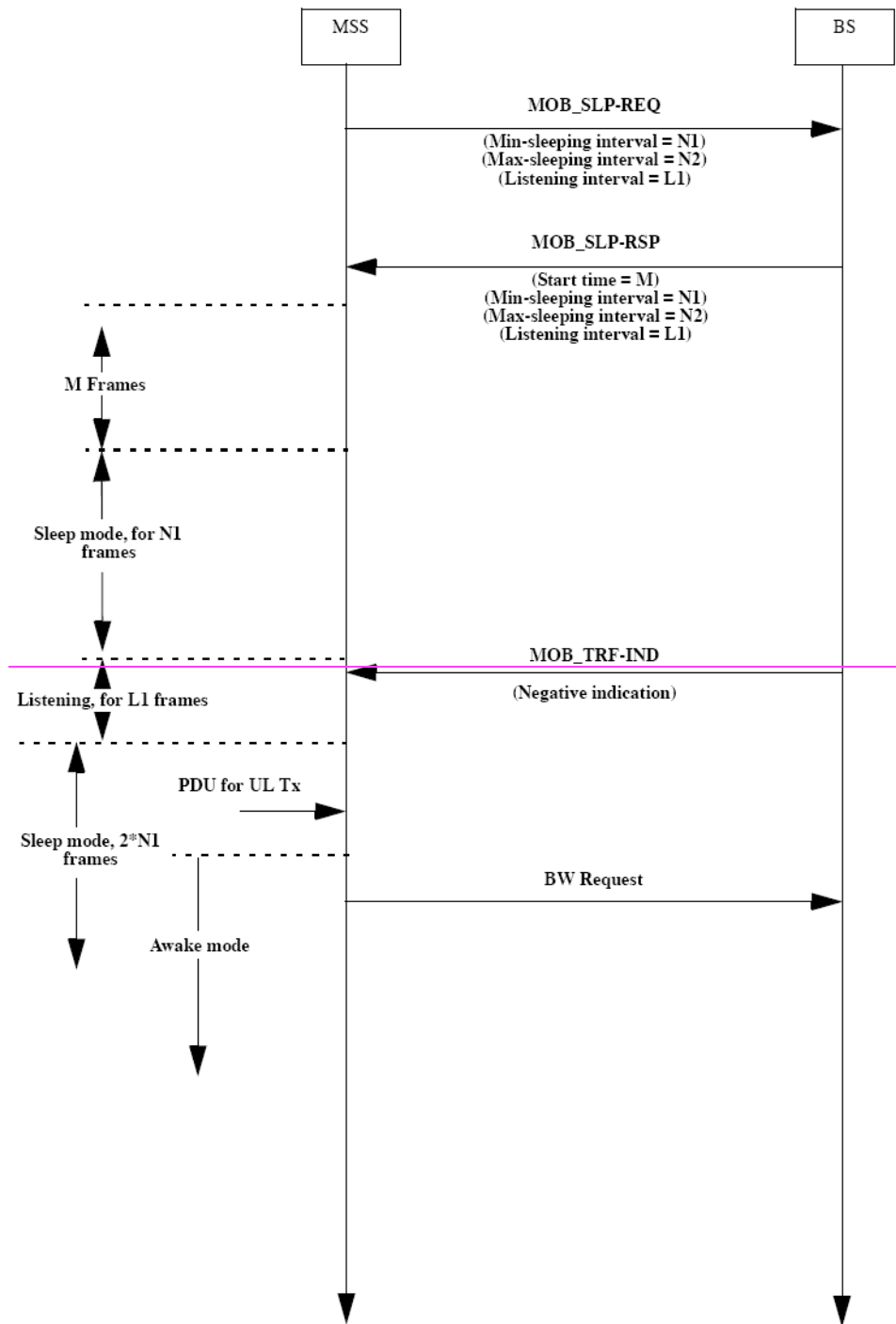

Figure D.13—Sleep mode, MSS initiating awakening

[To:]

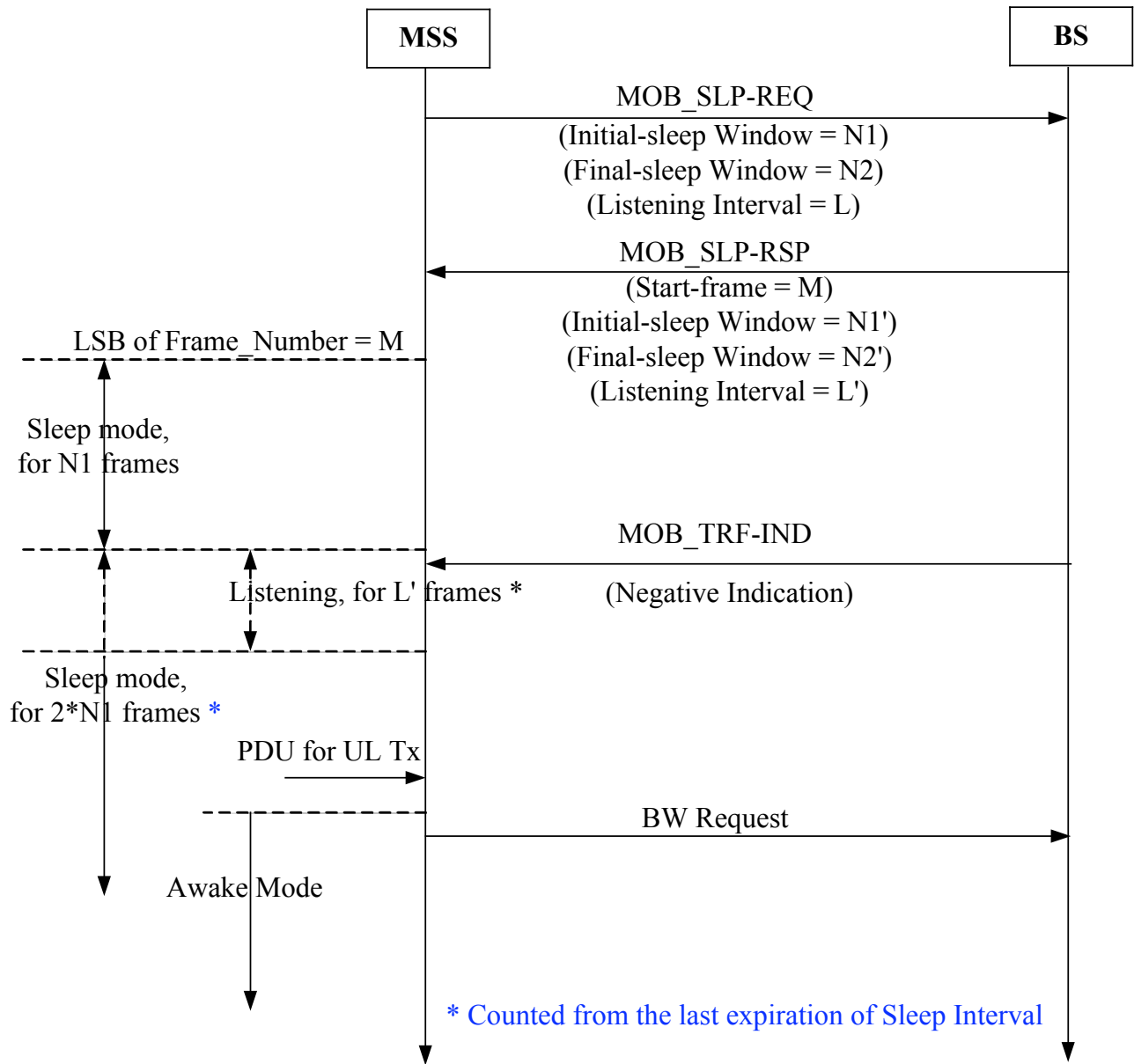

Figure D.13 – Sleep Mode – MSS initiated awakening