

ARQ and HARQ inter-working for IEEE 802.16m system

Document Number: IEEE C802.16m-08/1053

Date Submitted:
2008-09-05

Source:

Xiangying Yang (xiangying.yang@intel.com)

Yuan Zhu

Muthaiah Venkatachalam

Hujun Yin

Jie Hui

Intel Corporation

Intel Corporation

Intel Corporation

Intel Corporation

Intel Corporation

Venue: IEEE 802.16m-08/033 Call for Comments and Contributions on Project 802.16m System Description Document (SDD) for Session 57, on the topic of “Upper MAC (Data Plane Functions)”.

Base Contribution:

Purpose: Discussion and approval of the proposal into the IEEE 802.16m System Description Document

Notice:

This document does not represent the agreed views of the IEEE 802.16 Working Group or any of its subgroups. It represents only the views of the participants listed in the “Source(s)” field above. It is offered as a basis for discussion. It is not binding on the contributor(s), who reserve(s) the right to add, amend or withdraw material contained herein.

Release:

The contributor grants a free, irrevocable license to the IEEE to incorporate material contained in this contribution, and any modifications thereof, in the creation of an IEEE Standards publication; to copyright in the IEEE’s name any IEEE Standards publication even though it may include portions of this contribution; and at the IEEE’s sole discretion to permit others to reproduce in whole or in part the resulting IEEE Standards publication. The contributor also acknowledges and accepts that this contribution may be made public by IEEE 802.16.

Patent Policy:

The contributor is familiar with the IEEE-SA Patent Policy and Procedures:

<<http://standards.ieee.org/guides/bylaws/sect6-7.html#6>> and <<http://standards.ieee.org/guides/opman/sect6.html#6.3>>.

Further information is located at <<http://standards.ieee.org/board/pat/pat-material.html>> and <<http://standards.ieee.org/board/pat>>.

ARQ and HARQ in the reference system

- **HARQ**
 - PHY layer, fast feedback and error correction
 - Residual transmission error and feedback error (10^{-2})
- **ARQ**
 - MAC layer, (relatively slow) timer based error correction
 - Feedback CRC protected, reliable communication ($10^{-4} \sim 10^{-6}$)
- **Without coupling in the reference system**
 - waste resources: redundant retransmission, extra feedback
 - Delay: conservative ARQ retry timer leads to slow ARQ retransmission
 - ARQ is still necessary for TCP performance and MAC reliability

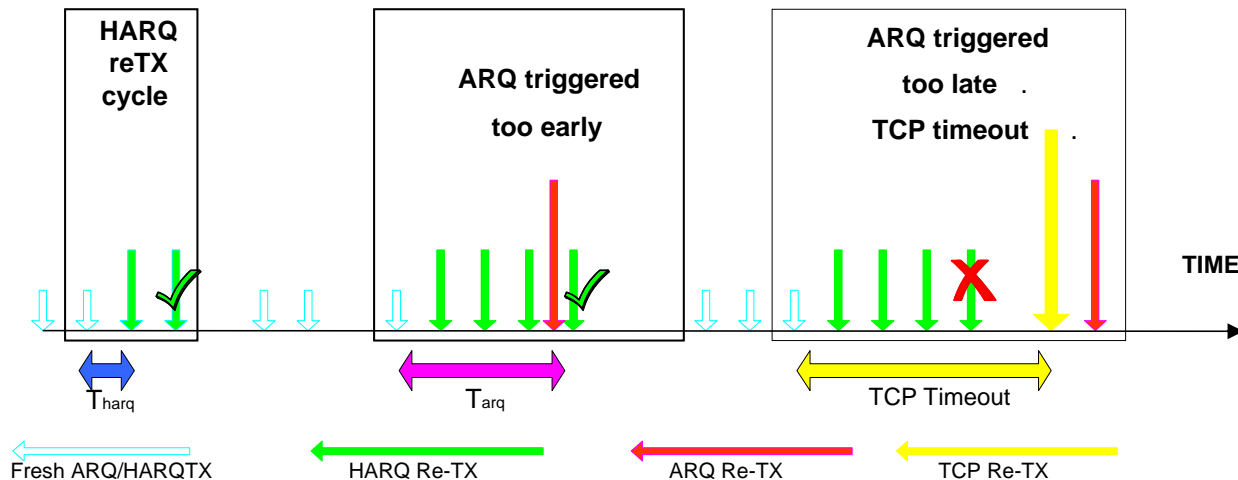

ARQ-HARQ inter-working proposal for IEEE 802.16m

Three basic coupled HARQ-ARQ operations

1. **ARQ NAK is internally triggered by HARQ reaching its max retransmission count, enabling ARQ fast retransmission**
 2. **ARQ ACK is internally triggered by HARQ ACK to save overhead (this eliminates ARQ ACK tx on the air)**
 3. **Other PHY layer errors (e.g. NAK→ACK) can not be handled by HARQ**
 - Detected by HARQ via early error detection
 - recovered by ARQ
- **#1 may be implemented separately; #2 and #3 are associated**

HARQ NACK triggers ARQ re-TX

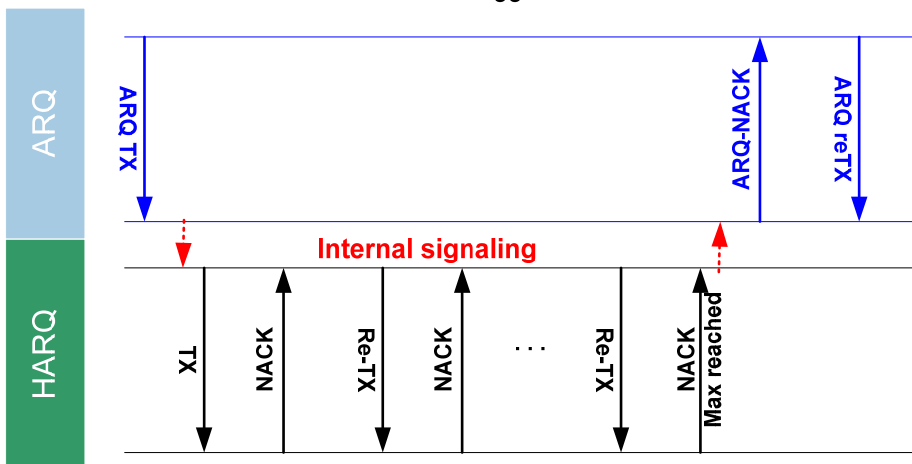

HARQ ACK triggers ARQ-ACK/Purge

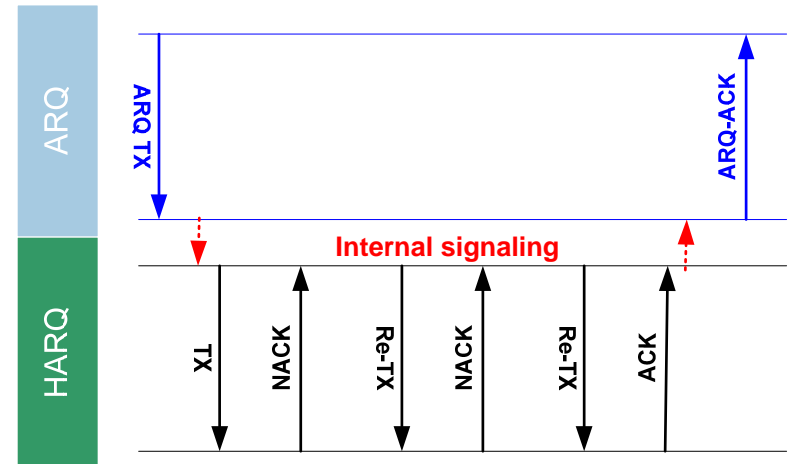

ARQ state diagram – TX side

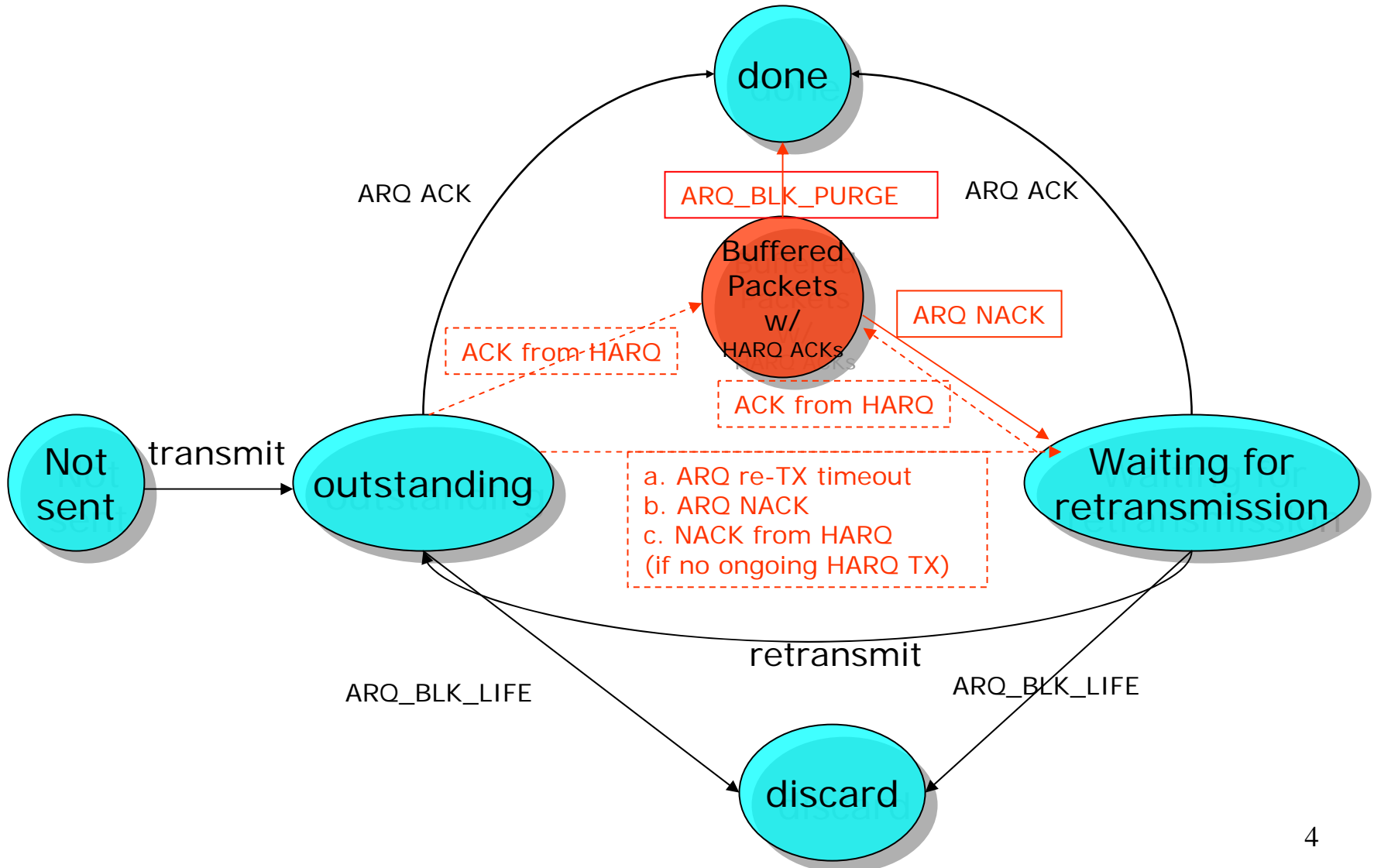

ARQ state machine – RX side

- ARQ RX schedules ACK when
 - ACK→NAK detected
 - Network entry at TBS during handover
- ARQ RX schedules feedback (NAK or NAK+ACK) when
 - NAK→ACK detected
 - HARQ residual error occurs
 - Last packet in the buffer (empty buffer or grant request)

Operation #1: ARQ fast retransmission

- HARQ reaching its max retransmission count and still in error
- ARQ NACK internally triggered to enable ARQ fast retransmission
- Requirement
 - interface between HARQ ARQ
 - Mapping between ARQ buffer (e.g. BSNs) to HARQ burst
 - Optionally, explicit ACK for both DL and UL significantly simplifies design
 - HARQ transmitter (MS) fully aware of whether the max # retransmission is successful
 - MS can realize HARQ residual error without possible latency

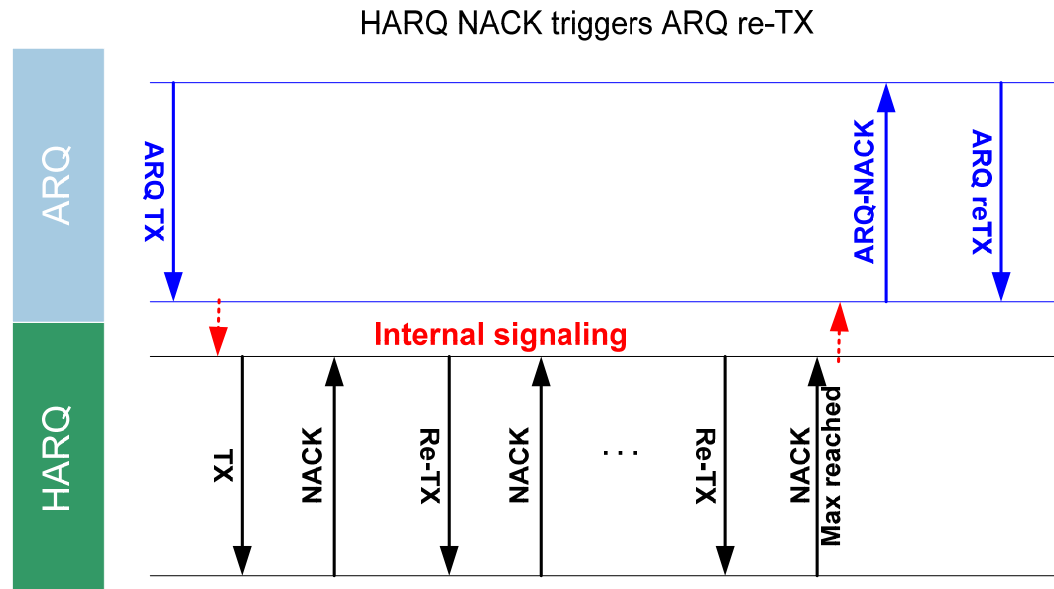

Operation #2: Removing ARQ ACK overhead

- HARQ receiver successfully received the pkt
- ARQ receiver does not send ARQ ACK
- HARQ transmitter sends an ACK to ARQ upon HARQ-ACK
- Requirement
 - All requirements in operation #1
 - Mechanisms to handle HARQ unusual errors for E2E reliability (i.e. #3)

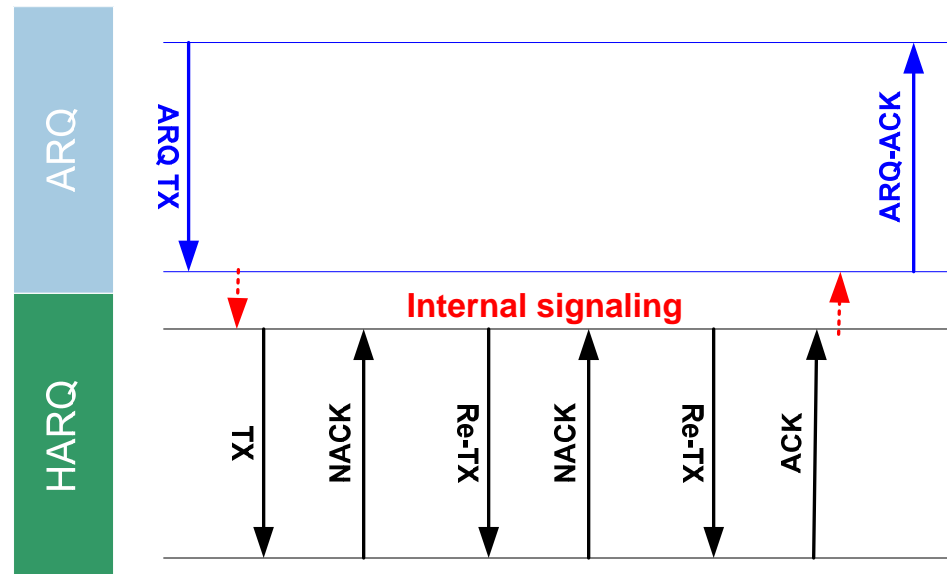

Operation #3: Enhance E2E reliability

- To further improve E2E reliability, ARQ must cover
 - HARQ feedback error
 - DL or UL
 - Ongoing traffic or the last packet
 - “<Max Re-TX count” or “= max Re-TX count”
 - DTX or DRX due to missed MAP or HARQ early termination
- ARQ original state machine still works for E2E reliability. Here are possible improvements to trigger fast error recovery.
- Requirement
 - #3 is only necessary when #2 is implemented
 - All requirements in #1, #2
 - HARQ feedback error detection
 - Special handling of the last DL pkt
- The design depends on HARQ configuration
 - implicit vs Explicit ACK (latter assumed in the sequel)
 - Synchronous vs Asynchronous HARQ (latter assumed)

NAK→ACK: DL, #TX<MAX, more data

- NAK→ACK can be easily detected
- ARQ feedback and retransmission will be triggered
- Same if BS HARQ transmitter early terminates the HARQ

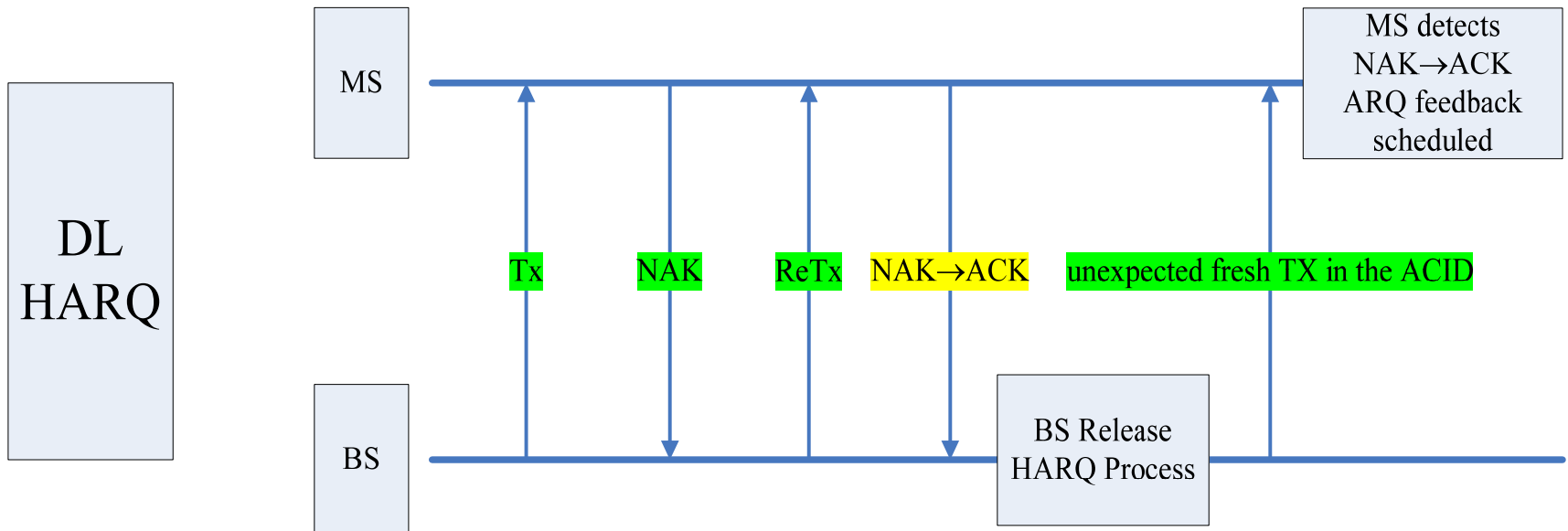

NAK→ACK: DL, #TX<MAX, no more data

- Without special handling, ARQ NAK still happens, but with extra latency
- Faster ARQ recovery possible with solution below
 - A MAC message or unsolicited scheduling grant using that ACID
 - If there is NAK→ACK, MS detects it; otherwise MS ignores it

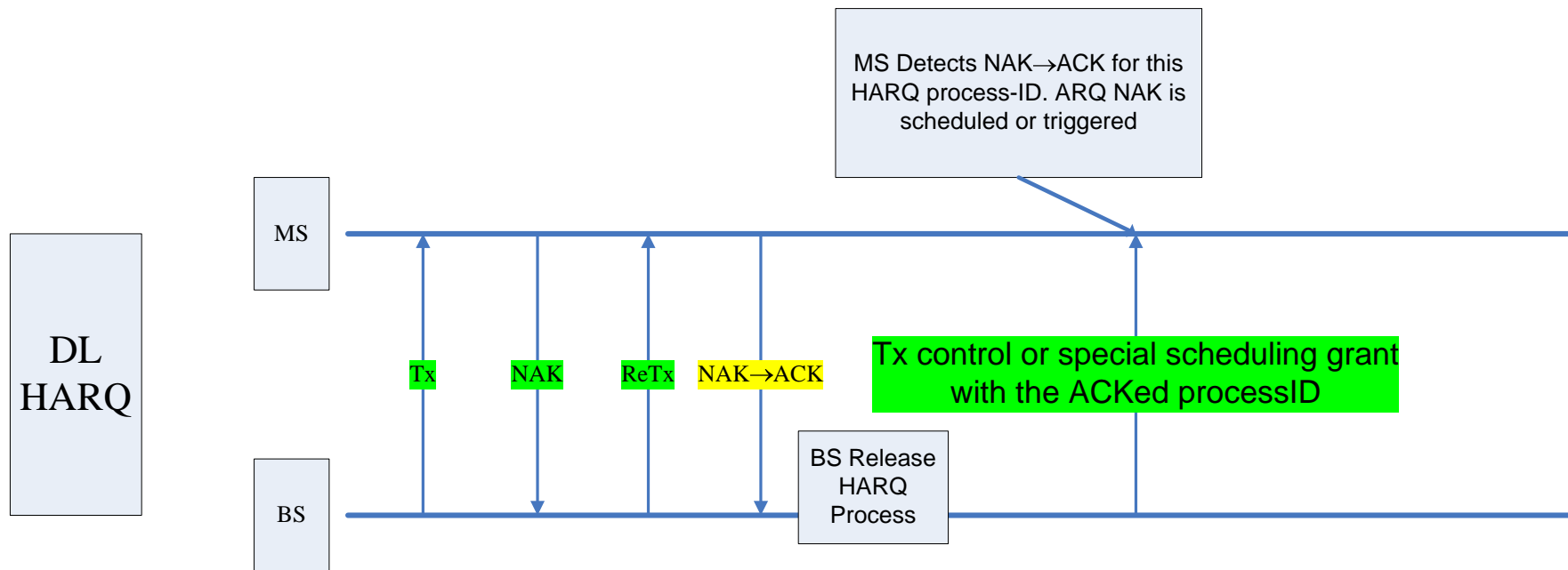

NAK→ACK: UL, #TX<MAX, regardless data

- If possible, don't recycle HARQ buffer
 - NAK→ACK can be detected and recovered at HARQ layer

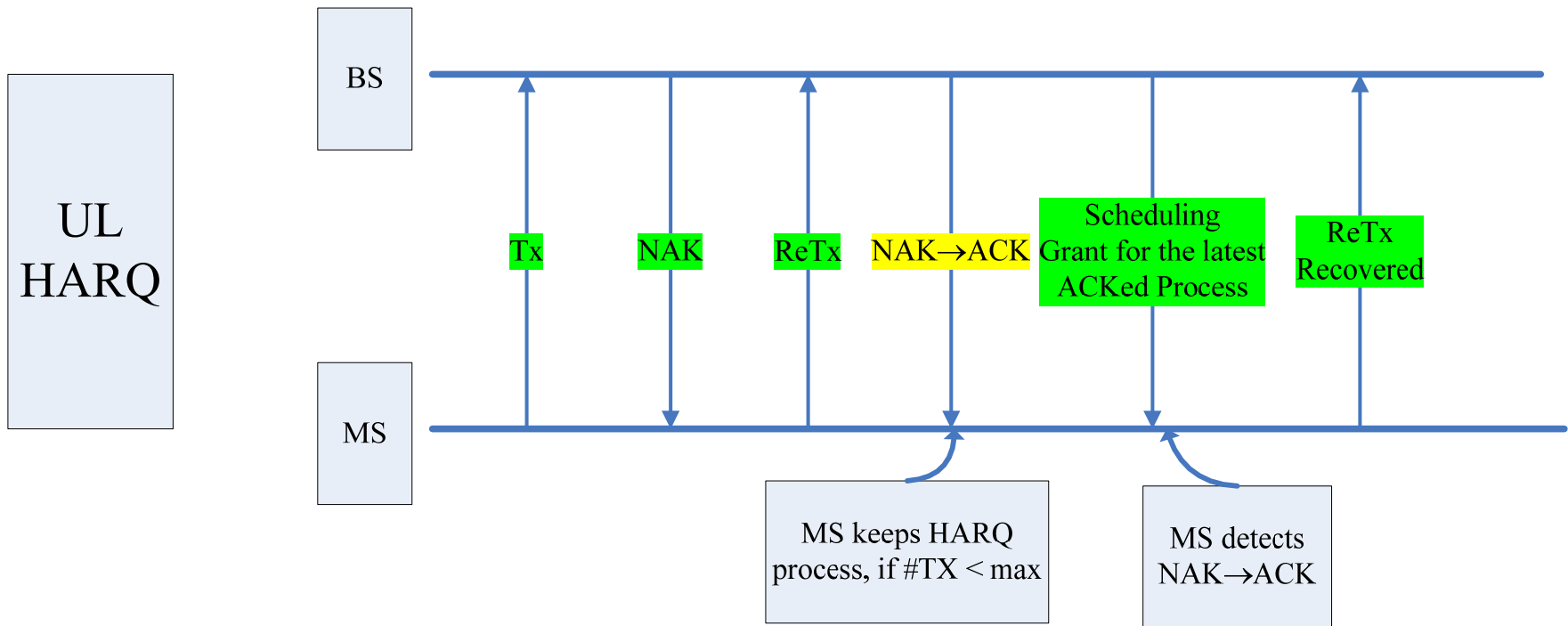

NAK→ACK: DL/UL, #TX=MAX

- Receiver side, ARQ NAK internally generated
- ARQ fast retransmission enabled anyway

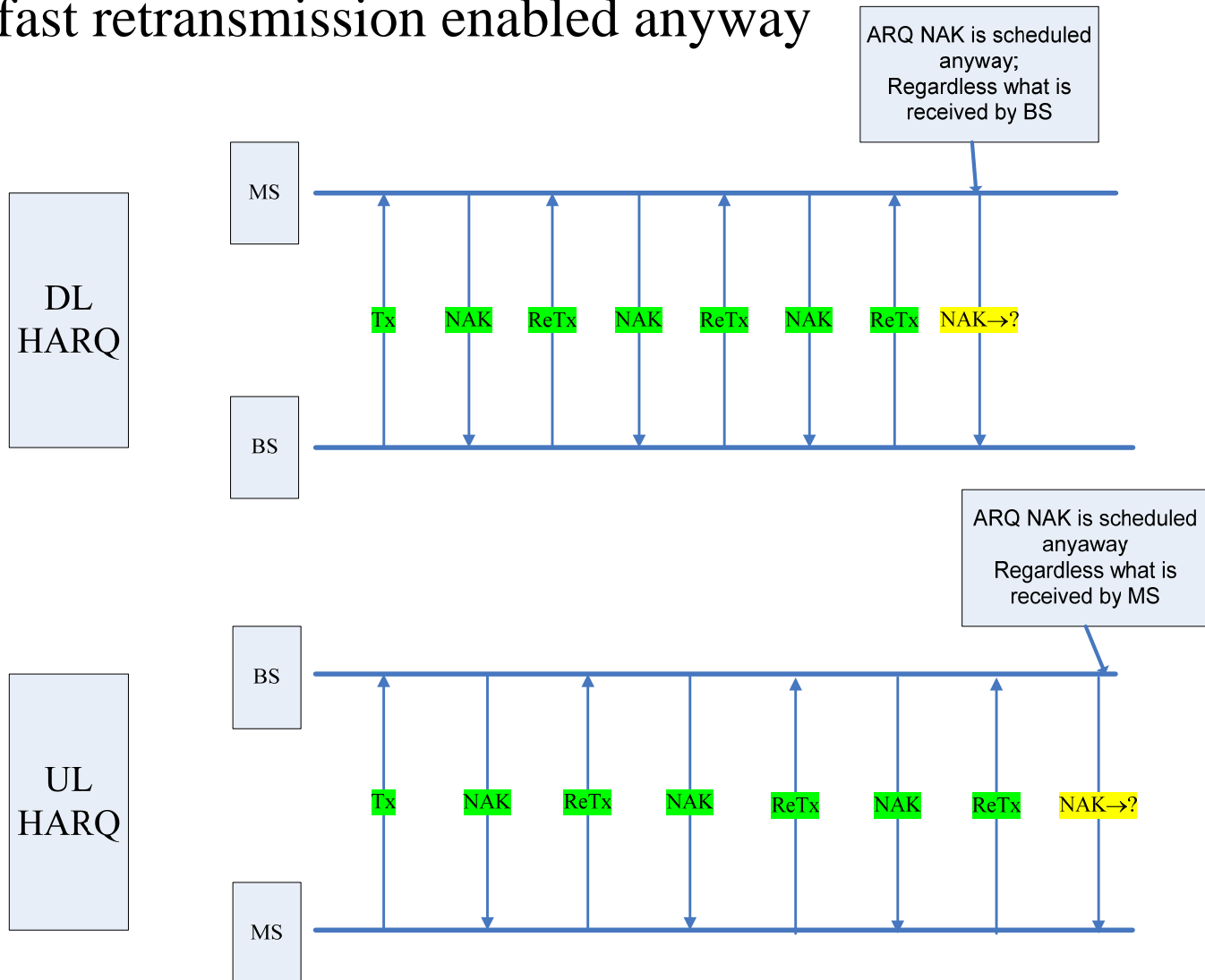

SDD proposal

[Insert the following text in section 10 in IEEE 802.16m-08/003r4]

----- *Text Starts* -----

10.x ARQ

10.x.x ARQ and HARQ inter-working

When the HARQ burst fails transmission, HARQ transmitter informs the ARQ entity about the associated MAC PDU in the burst. ARQ marks these PDU as failed and prepares for retransmission.

When the HARQ burst succeed with transmission, HARQ transmitter informs the ARQ entity about the associated MAC PDU in the burst. ARQ marks these PDU as HARQ-ACK'ed and keep them in the buffer until some timer expires. ARQ receiver does not need to send ACK for the associated PDU.

IEEE 802.16m MAC entity detects HARQ feedback error and triggers corresponding recovery procedures at HARQ or ARQ layer.

----- *Text Ends* -----