

Project	<b>IEEE 802.16 Broadband Wireless Access Working Group</b> < <a href="http://ieee802.org/16">http://ieee802.org/16</a> >	
Title	<b>Pilot design for precoding in Multiuser MIMO on IEEE802.16m downlink</b>	
Date Submitted	<b>2008-03-10</b>	
Source(s)	<p>Tsuguhide Aoki, Shohei Kikuchi, Hiroki Mori  Toshiba Mobile Communication Laboratory,  Corporate R&amp;D Center,  Toshiba Corporation, 1, Komukai Toshiba-Cho, Saiwai-ku, Kawasaki, 212-8582, Japan</p> <p>Yong Sun, Henning Vetter  Toshiba Research Europe Limited  32 Queen Square, Bristol BS34 8HL, UK</p>	<p>Voice: +81-44-549-228381  Email: <a href="mailto:tsuguhide.aoki@toshiba.co.jp">tsuguhide.aoki@toshiba.co.jp</a></p> <p>Voice: +44-117-9060749  Email <a href="mailto:Sun@toshiba-trel.com">Sun@toshiba-trel.com</a></p> <p>*&lt;<a href="http://standards.ieee.org/faqs/affiliationFAQ.html">http://standards.ieee.org/faqs/affiliationFAQ.html</a>&gt;</p>
Re:	<p>In response to the Call for Contributions on Project 802.16m System Description Document (SDD) issued on 2008-01-24 (IEEE 802.16m-08/005 )</p> <p>Topic covered: Pilot Structures as relevant to downlink MIMO</p>	
Abstract	This proposal present a pilot design and structure to support precoding on downlink MIMO	
Purpose	For discussion and approval by IEEE 802.16m TG	
Notice	<i>This document does not represent the agreed views of the IEEE 802.16 Working Group or any of its subgroups. It represents only the views of the participants listed in the "Source(s)" field above. It is offered as a basis for discussion. It is not binding on the contributor(s), who reserve(s) the right to add, amend or withdraw material contained herein.</i>	
Release	The contributor grants a free, irrevocable license to the IEEE to incorporate material contained in this contribution, and any modifications thereof, in the creation of an IEEE Standards publication; to copyright in the IEEE's name any IEEE Standards publication even though it may include portions of this contribution; and at the IEEE's sole discretion to permit others to reproduce in whole or in part the resulting IEEE Standards publication. The contributor also acknowledges and accepts that this contribution may be made public by IEEE 802.16.	
Patent Policy	<p>The contributor is familiar with the IEEE-SA Patent Policy and Procedures:  &lt;<a href="http://standards.ieee.org/guides/bylaws/sect6-7.html#6">http://standards.ieee.org/guides/bylaws/sect6-7.html#6</a>&gt; and  &lt;<a href="http://standards.ieee.org/guides/opman/sect6.html#6.3">http://standards.ieee.org/guides/opman/sect6.html#6.3</a>&gt;.</p> <p>Further information is located at &lt;<a href="http://standards.ieee.org/board/pat/pat-material.html">http://standards.ieee.org/board/pat/pat-material.html</a>&gt; and  &lt;<a href="http://standards.ieee.org/board/pat">http://standards.ieee.org/board/pat</a>&gt;.</p>	

## Pilot design for precoding in Multiuser MIMO on IEEE802.16m downlink

*Tsuguhide Aoki, Shohei Kikuchi, Hiroki Mori*

*Mobile Communication Laboratory, Corporate R&D Center, Toshiba Corporation,  
1, Komukai Toshiba-Cho, Saiwai-ku, Kawasaki, 212-8582, Japan*

*Yong Sun, Henning Vetter*

*Toshiba Research Europe Limited, 32 Queen Square, Bristol BS34 8HL, UK*

### Introduction

This contribution is provided in response to the Call for Contribution on Project 802.16m System Description Document (SDD) issued on 2008-01-24 (IEEE 802.16m-08/005 ) to propose a pilot design and structure to support precoding on downlink MIMO.

In time-division duplexed (TDD) systems, channel estimates on the uplink transmission might be utilized at the base station to employ precoding on the downlink. A multiple antenna base station can transmit spatially multiplexed streams over shared frequency resources. This can be a single-user (SU-MIMO) transmission, when all spatial streams are allocated to a single user, or a multi-user (MU-MIMO) transmission, when multiple users are served.

Further to our previous contribution [C80216m-08/058r1] on Vector Perturbation, we introduce a MU-MIMO technique based on Multiuser Tomlinson Harashima Precoding (THP) in this contribution. In addition we also introduce a problem for the channel estimation and propose a pilot structure to solve the problem.

### Description of Multiuser Tomlinson Harashima Precoding (THP)

Channel Inversion (CI) precoding overcomes the changes made by the channel during the transmission by applying the Moore-Penrose pseudo inverse of the channel at the transmitter side, i.e., the data vector is precoded in order to remove inter-user interference. The basic assumption at this point is therefore perfect channel state information (CSI). A drawback of CI precoding is the increase of the transmit power [1]. Prior to transmission, the precoded signal has to be scaled in order to normalize the transmit power according to the restrictions of the base station. In order to solve the problem, the multiuser THP uses modulo operation to reduce the transmit power, in combination with the successive cancellation at the transmitter. The block diagram of the multiuser THP is shown in Figure 1.

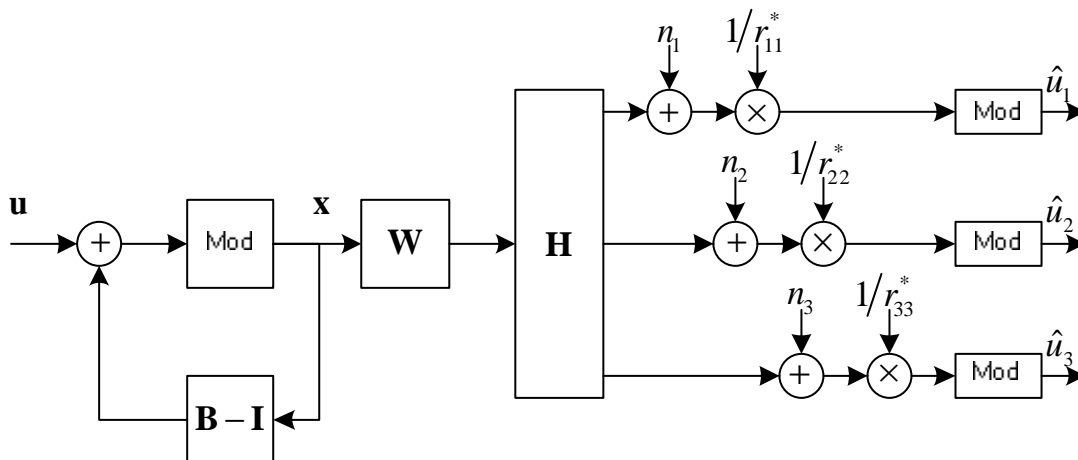

Figure 1: Block diagram of the multiuser THP

In the multiuser THP, a channel matrix can be decomposed as

$$\mathbf{H} = \mathbf{R}^H \mathbf{Q}^H \quad (1)$$

where  $\mathbf{Q}$  is a unitary matrix and  $\mathbf{R}$  is an upper triangular. We can then define the feedback matrix  $\mathbf{B}$ , with ones on the diagonal, as

$$\mathbf{B} = \mathbf{G} \mathbf{R}^H \quad (2)$$

where the scaling matrix  $\mathbf{G} = \text{diag}\left(\left(r_{11}^*\right)^{-1}, \left(r_{22}^*\right)^{-1}, \dots, \left(r_{KK}^*\right)^{-1}\right)$ . Because the triangular structure of the feedback matrix  $\mathbf{B}$ , the symbols  $x_k$ , are successively generated from the data symbols

$$u_k \in A = \left\{ a_l + ja_l \mid a_l, a_l \in \pm 1, \pm 3, \dots, (\sqrt{M} - 1) \right\}$$

$$x_k = u_k - \sum_{l=1}^{k-1} b_{kl} x_l, k = 1, \dots, K \quad (3)$$

Since this strategy would increase transmit power significantly, the modulo reduction reduces the transmit symbols into the boundary region of  $A$ . Mathematically, integer multiples of  $2\sqrt{M}$  are added to the real and imaginary part of  $x_k$ . Now, the channel symbols are given as

$$x_k = u_k + p_k - \sum_{l=1}^{k-1} b_{kl} x_l \quad (4)$$

where  $p_k \in \left\{ 2\sqrt{M} \cdot (p_l + jp_l) \mid p_l, p_l \in \mathbf{Z} \right\}$ . In other words, instead of feeding the data symbols  $u_k$  into the linear pre-equalization, the effective data symbols  $v_k = u_k + p_k$  are passed into  $\mathbf{B}^{-1}$ , which is implemented by the feedback structure. Note that this choice is unique and done implicitly by the modulo operation.

The output of the modulo operator is input to the feed forward matrix  $\mathbf{W}$  that can be defined as

$$\mathbf{W} = \mathbf{Q}. \quad (5)$$

It is worth noting that the signal  $\mathbf{x}$  is in the boundary region of  $A$  and the feed forward matrix is unitary so that there is no power penalty in multiuser THP.

The received signal denoted by  $\mathbf{y}$ , can be written as

$$\begin{aligned} \mathbf{y} &= \mathbf{H} \frac{1}{\sqrt{g}} \mathbf{W} \mathbf{x} + \mathbf{n} = \frac{1}{\sqrt{g}} \mathbf{H} \mathbf{Q} \mathbf{B}^{-1} \mathbf{v} + \mathbf{n} \\ &= \frac{1}{\sqrt{g}} \mathbf{R}^H \left( \mathbf{G} \mathbf{R}^H \right)^{-1} \mathbf{v} + \mathbf{n} \\ &= \frac{1}{\sqrt{g}} \mathbf{G}^{-1} \mathbf{v} + \mathbf{n} \\ &= \frac{1}{\sqrt{g}} \mathbf{G}^{-1} (\mathbf{u} + \mathbf{p}) + \mathbf{n} \end{aligned} \quad (6)$$

where  $g = \|\mathbf{W} \mathbf{x}\|^2$ .

Since the  $\mathbf{G}^{-1}$  is a diagonal, the interference at the users are eliminated. After the scaling operation of  $\sqrt{g} \mathbf{G}$ , the received

signal is fed into the modulo reduction at the receiver and the original sequence  $u$  is recovered, because the modulo reduction is a unique operation.

## Performance of the multiuser THP

In the section we demonstrate the performance achieved by the proposed non-linear technique Tomlinson-Harashima Precoding (THP) compared to linear Channel Inversion (CI) precoding. Here, we consider a multi-user downlink with a Gaussian MIMO channel. We assume a base station having two or four transmit antennas, and two or four users equipped with one receive antenna each, respectively. We further assume perfect channel knowledge at the transmitter. In each frame, spatial streams are being transmitted to the users, one per user.

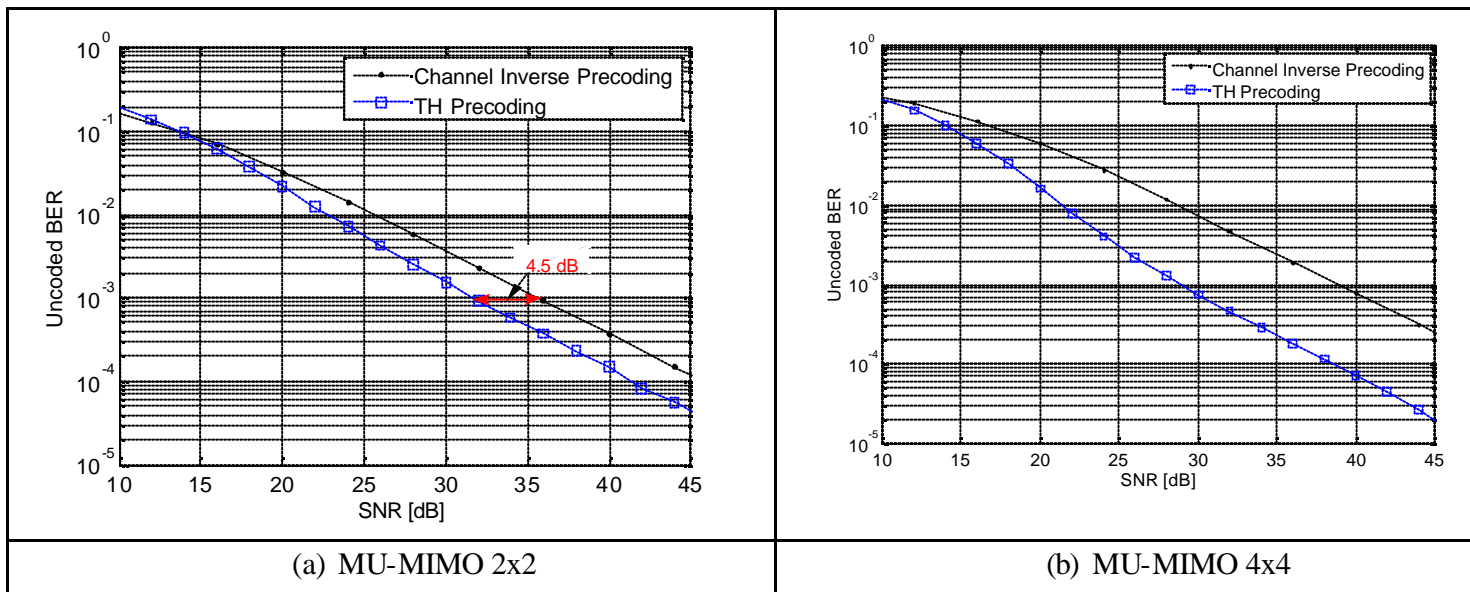

Figure 2: Comparison of THP and Channel Inverse Precoding

Note that MU-MIMO 2x2 is the configuration of 2 transmit antennas with 2 users with 1 antenna each and MU-MIMO 4x4 is for 4 transmit antenna with 4 users. Figure 2 shows the average performance of an uncoded transmission using 16-QAM modulation. The gain in terms of uncoded bit error rate (UBER) between Channel Inversion Precoding and multiuser THP is evident, as we can observe a performance gap of approx. 10 dB and 5 dB respectively at the 0.1% UBER line, which has shown clearly that the proposed nonlinear THP precoding achieves significant gain over linear precoding.

## Proposed pilot structure

In 802.16e, precoding was specified to employ the dedicated pilot (pilot is precoded in the same way as data) in order for MS to estimate the effective channel  $\mathbf{g}^{-1/2}\mathbf{G}$  without any knowledge of the precoding scheme. However in the multiuser THP, because the increase of the data symbols is compensated by the modulo reduction, it cannot be used for the pilot because the pilot have to reflect the channel state information. The reduction of the modulo part could be a straight forward manner to transmit the pilot, however, there must be a problem of the increase of transmit power owing to the feedback matrix and it decreases the channel estimation performance.

In this contribution we propose to use the feedforward matrix for the transmission of the pilot. Here we show the examples for 2x2 system. The received pilot represented by  $y_{pilot}$  is written as

$$\begin{aligned}
 \mathbf{y}_{pilot} &= \mathbf{H} \frac{1}{\sqrt{\mathbf{g}}} \mathbf{W} \mathbf{u}_{pilot} + \mathbf{n}_{pilot} \\
 &= \frac{1}{\sqrt{\mathbf{g}}} \mathbf{R}^H \mathbf{Q}^H \mathbf{Q} \mathbf{u}_{pilot} + \mathbf{n}_{pilot} \\
 &= \frac{1}{\sqrt{\mathbf{g}}} \mathbf{R}^H \mathbf{u}_{pilot} + \mathbf{n}_{pilot} \\
 &= \frac{1}{\sqrt{\mathbf{g}}} \begin{bmatrix} r_{11}^* u_{pilot,1} \\ r_{22}^* u_{pilot,2} + r_{12}^* u_{pilot,1} \end{bmatrix} + \mathbf{n}_{pilot}
 \end{aligned} \tag{7}$$

Since only the unitary matrix is used, this transmit signal does not suffer from the power penalty. The received signal, however, suffers from the interference owing to the triangular structure of  $\mathbf{R}^H$ . It can be eliminated by using the orthogonal structure of the pilot and the pilot allocation. Figure 3 shows one example of the pilot structure and allocation with multiuser THP.

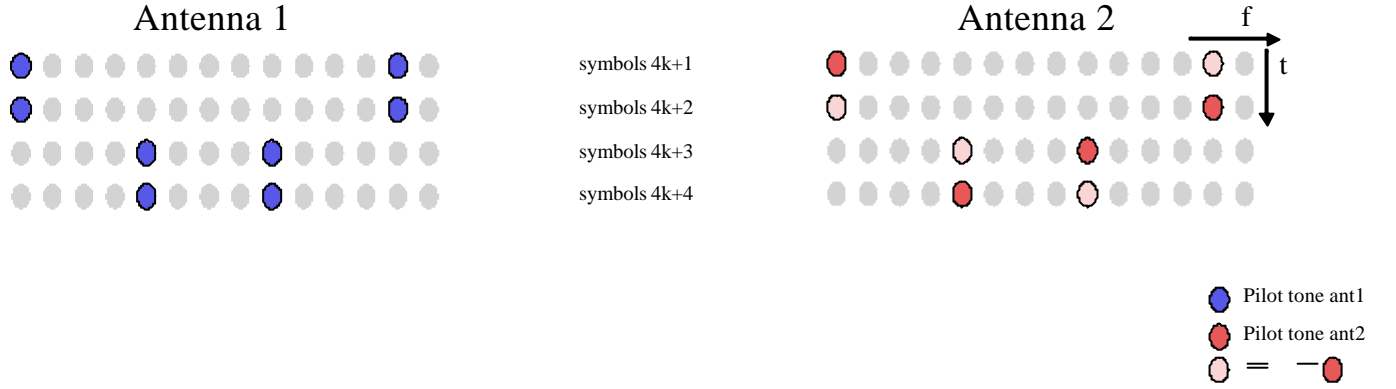

Figure 3: Designed pilot structure and allocation with multiuser THP

For example, the stream 1 transmits  $u_{pilot,1}$  and  $u_{pilot,2}$  at the symbols of  $4k+1$  and of  $4k+2$ , respectively. On the other hand, the stream 2 transmits  $u_{pilot,1}$  and  $-u_{pilot,2}$ , respectively. The orthogonal operation within the two symbols can eliminate the interference in (7). Note that any other pilot patterns can be used as long as the pilot is unitary-beamformed and its allocation is orthogonal in the frequency or time domain. The legacy pilot allocation (e.g., pilot is only transmitted from single antenna at the same resource) is also used in this scheme.

## Channel estimation performance

We'll show how much degradation occurs in a straightforward manner (denoted as *straightforward*) and also show the proposed structure can solve the problem. The mean square errors (MSE) of the pilot estimation is calculated to evaluate the channel estimation performance. For example, the MSE for user 1 is

$$MSE = E \left\{ \left( r_{11}^* - \hat{r}_{11}^* \right)^2 \right\} = E \left\{ \left( r_{11}^* - r_{11}^* - \sqrt{\mathbf{g}} n_1 \right)^2 \right\} = E \{ \mathbf{g} \} \mathbf{s}_n^2 \tag{8}$$

In the straightforward scheme, the transmit power denoted by  $\mathbf{g}_s$  is written as

$$\mathbf{g}_s = \|\mathbf{W}\mathbf{x}\|^2 = \|\mathbf{Q}\mathbf{B}^{-1}\mathbf{u}\|^2 = \mathbf{u}^H \mathbf{B}^{-H} \mathbf{B}^{-1} \mathbf{u} \quad (9)$$

On the other hand, the transmit power of the proposed scheme becomes

$$\mathbf{g}_p = \|\mathbf{W}\mathbf{x}\|^2 = \|\mathbf{Q}\mathbf{u}\|^2 = \|\mathbf{u}\|^2 = \mathbf{s}_s^2 \quad (10)$$

The definition of the SNR is  $SNR = \frac{\mathbf{s}_s^2}{\mathbf{s}_n^2}$ , where  $\mathbf{s}_n^2$  shows the noise variance. The gain achieved by using the proposed scheme can be written as  $\mathbf{g}_s/\mathbf{g}_p$ .

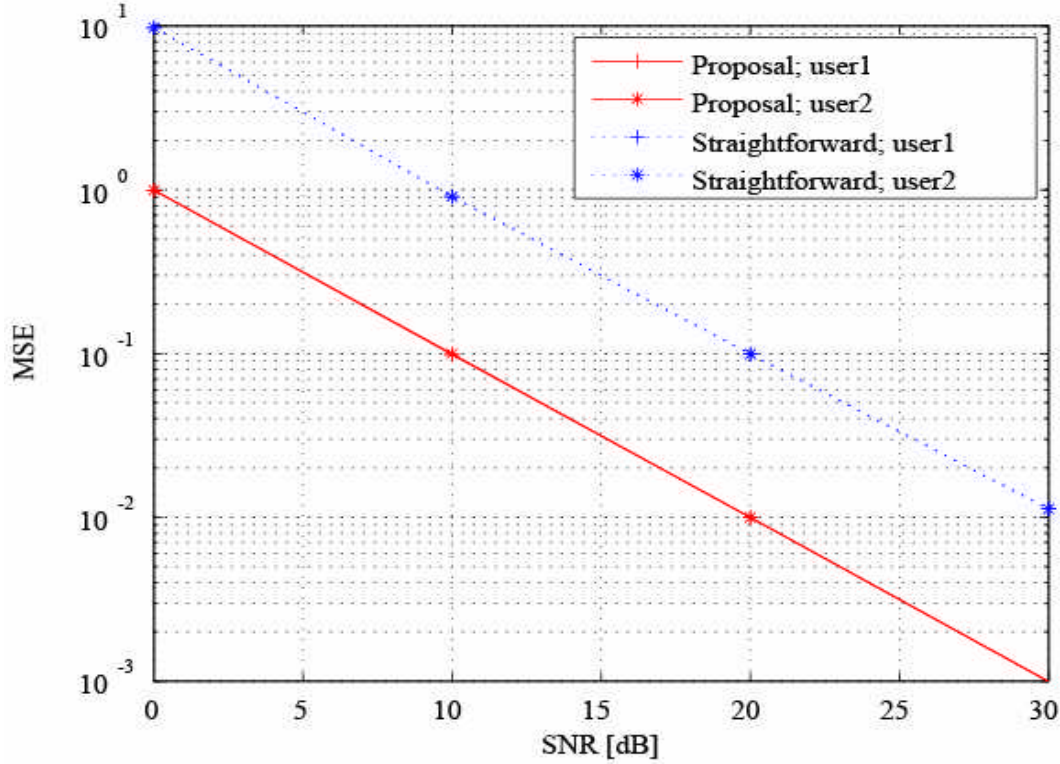

Figure 4: MSE performance of channel estimation

Figure 4 shows the MSE performance of the channel estimation by using computer simulation. The channel is iid fat-Raleigh fading channel. It can be seen that the MSE of the straightforward pilot structure suffer from the power penalty as in (9). By using the proposed algorithm, the MSE performance is improved as predicted in (10).

## Conclusions and recommendations

Multiuser THP is proposed to be one of the technique for the MU-MIMO which shall be specified in the System Description Document (SDD). The multiuser THP gives better performance than the linear channel inversion algorithm. However, there is a problem of transmitting the pilot signal. The proposed algorithm can transmit the pilot without power penalty, and therefore it represented better channel estimation performance.

We propose to specify Multiuser THP in SDD with proposed pilot structure.

~~~~~ **Text Input start** ~~~~~

**x.x.x MU-MIMO**

[Insert the following subclause]

**x.x.x.y Multiuser THP**

The multiuser THP uses the modulo operation in combination with the successive cancellation at the transmitter.

**x.x.x.y.z Pilot structure to support 2x2 MU-MIMO**

For MU-MIMO THP operation, the pilot structure shall have a converse pilot pattern on one stream. There is no restriction on location of the pilot which can adopt legacy pilot pattern. One example of the pilot structure for Multiuser THP is defined as shown in Figure xyz to support 2x2 MU-MIMO.

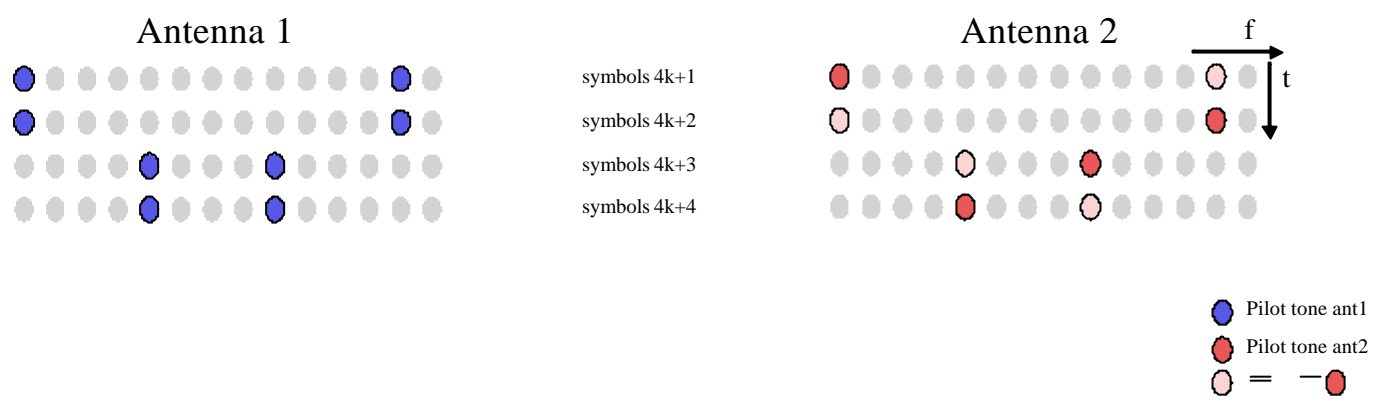

Figure xyz: Designed pilot structure and allocation with multiuser THP

In the multiuser THP, pilot is beamformed based on the feed forward unitary matrix to fit the power constraint while data is beamformed by the feed forward and feedback matrix. The interference at the users is eliminated by the orthogonal structure of the pilot allocation as shown in Fig xyz.

**yyy. TLV Encodings**

**yyy.x. SS capabilities encodings**

[Insert new subclaus yyy.x.yz]

**yyy.x.yz. Modulo capability support**

| Name              | Type | Length | Value                | Scope   |
|-------------------|------|--------|----------------------|---------|
| Modulo capability | TBD  | 1      | 0: no modulo support | REG-REQ |
|                   |      |        | 1: modulo support    | REG-RSP |

**yyy.y. Modulo mode support**

This field indicates the SS operation mode. A SS uses this field in SBC -REQ in indicate its modulo operation mode. The BS uses this field in SBC -RSP to confirm the SS mode.

| Name | Type | Length | Value | Scope |
|------|------|--------|-------|-------|
|------|------|--------|-------|-------|

|             |     |   |                                     |             |
|-------------|-----|---|-------------------------------------|-------------|
| Modulo mode | TBD | 1 | 0: no modulo mode<br>1: modulo mode | SBC-REQ/RSP |
|-------------|-----|---|-------------------------------------|-------------|

**yyy.z. MU-MIMO feature support**

This TLV indicates the MU-MIMO features supported by the BS

| Name            | Type | Length | Value                                                                                        | Scope              |
|-----------------|------|--------|----------------------------------------------------------------------------------------------|--------------------|
| MU-MIMO feature | TBD  | 1      | Bit #0: Linear Precoding<br>Bit #1: Vector Perturbation<br>Bit #2: THP<br>Bit #3-7: Reserved | REG-REQ<br>REG-RSP |

While the TLV indicates the MU-MIMO features supported by the BS is THP precoding, the pilot specified in subclause x.x.x.y.z shall be adopted.

~~~~~ **Text Input end** ~~~~~

**References**

[1] C. Windpassinger, R. F. H. Fischer, T. Vencel, and J. B. Huber, "Precoding in multiantenna and multiuser communications," *IEEE Trans. Wireless Commun.*, vol. 3, no. 4, pp. 1305-1316, July 2004.