

Project	<b>IEEE 802.16 Broadband Wireless Access Working Group</b> < <a href="http://ieee802.org/16">http://ieee802.org/16</a> >	
Title	<b>Proposal for PHY Control Channels for Interference Mitigation in IEEE 802.16m</b>	
Date Submitted	<b>2008-07-07</b>	
Source(s)	Yang-Han Lee, Yih-Guang Jan, Ming-Hsueh Chuang, Hsien-Wei Tseng, Po-Jung Lin, Ting-Chien Wang	<a href="mailto:yhlee@ee.tku.edu.tw">yhlee@ee.tku.edu.tw</a>
	<b>Tamkang University (TKU)</b>	
	Kanchei (Ken) Loa, Chih-Wei Su, Yung-Ting Lee, Hua-Chiang Yin, Youn-Tai Lee	<a href="mailto:loa@nmi.iii.org.tw">loa@nmi.iii.org.tw</a>
	<b>Institute for Information Industry (III)</b>	
	Shiann-Tsong Sheu	<a href="mailto:stsheu@ce.ncu.edu.tw">stsheu@ce.ncu.edu.tw</a>
	<b>National Central University (NCU)</b>	
Re:	IEEE 802.16m-08/024: Call for Contributions on Project 802.16m System Description Document (SDD). Target topic: "Interference Mitigation".	
Abstract	This contribution proposes for PHY Control Channels for Interference Mitigation	
Purpose	To be discussed and adopted by TGM for the 802.16m SDD.	
Notice	<i>This document does not represent the agreed views of the IEEE 802.16 Working Group or any of its subgroups. It represents only the views of the participants listed in the "Source(s)" field above. It is offered as a basis for discussion. It is not binding on the contributor(s), who reserve(s) the right to add, amend or withdraw material contained herein.</i>	
Release	The contributor grants a free, irrevocable license to the IEEE to incorporate material contained in this contribution, and any modifications thereof, in the creation of an IEEE Standards publication; to copyright in the IEEE's name any IEEE Standards publication even though it may include portions of this contribution; and at the IEEE's sole discretion to permit others to reproduce in whole or in part the resulting IEEE Standards publication. The contributor also acknowledges and accepts that this contribution may be made public by IEEE 802.16.	
Patent Policy	The contributor is familiar with the IEEE-SA Patent Policy and Procedures: < <a href="http://standards.ieee.org/guides/bylaws/sect6-7.html#6">http://standards.ieee.org/guides/bylaws/sect6-7.html#6</a> > and < <a href="http://standards.ieee.org/guides/opman/sect6.html#6.3">http://standards.ieee.org/guides/opman/sect6.html#6.3</a> >. Further information is located at < <a href="http://standards.ieee.org/board/pat/pat-material.html">http://standards.ieee.org/board/pat/pat-material.html</a> > and < <a href="http://standards.ieee.org/board/pat">http://standards.ieee.org/board/pat</a> >.	

# Proposal for PHY Control Channels for Interference Mitigation in IEEE 802.16m

*Yang-Han Lee, Yih-Guang Jan, Ming-Hsueh Chuang, Hsien-Wei Tseng, Po-Jung Lin, Ting-Chien Wang*  
*Tamkang University (TKU)*

*Kanchei (Ken) Loa, Chih-Wei Su, Yung-Ting Lee, Hua-Chiang Yin, Youn-Tai Lee*  
*Institute for Information Industry (III)*  
*Shiann-Tsong Sheu*  
*National Central University (NCU)*

## 1. Introduction

In wireless communication it incurs many types of interferences. The interferences can be classified into three classes as interference between BS and MS, between MSs and between BSs. For the Interference Mitigation we define several DL/UL control channels in the IEEE 802.16m and from the control information conveyed between the BS and MS so as to initiate the Interference Mitigation process to reduce the possible interference effect in the data transmission between the MS and BS.

## 2. Frame Structure for Control Channels

### 2.1 Type A Frame Structure for Control Channels

Type A frame structure for control channels has the structure as shown in Fig. 1. Its DL control flow is shown in Fig. 2. There are six types of control channels in the frame as described in the following:

**2.1.1 Super Frame Header (SFH):** The SFH is used for the transmission of the information such as the synchronization, frequency reference, cell ID etc.

**2.1.2 Frame Header (FH):** The FH identifies which frame should activate an interference reducing zone (IR-Zone), and when an IR- Zone is activated then the MS in this region will receive the interference reducing service.

**2.1.3 Frame Map (FM):** This FM is used to designate MSs' locations in the sub-frame for those MSs are in the interference-reducing region.

**2.1.4 Sub-frame Map (SFM):** The SFM is used to designate which MSs in this IR-Zone need the interference reducing service. The MS designated can be a group of MSs or a single MS. It gives MS the information it is in the interference reducing zone, the proper pilot pattern and it also provides the relative location information of the MS request UL- Zone.

**2.1.5 Interference Reducing Zone (IR-Zone):** This zone is activated by the BS it can be divided into UL and DL IR-Zones. The zone's size and location are described in the FH and the SFM it also serves those MSs that need interference reducing services.

**2.1.6 Uplink-interference Reducing Request (UL-IRR):** the MS will send an interference reducing request in this frame and the BS will include this MS which sends this request in the IR-Zone in the next DL frame.

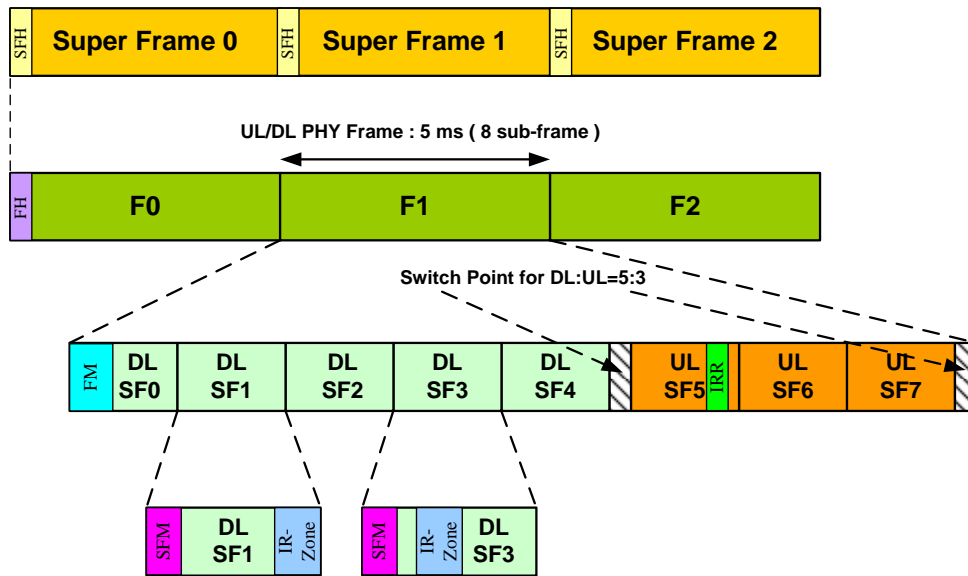

Fig. 1 Type A Frame Structure for Control Channels (TDM Mode)

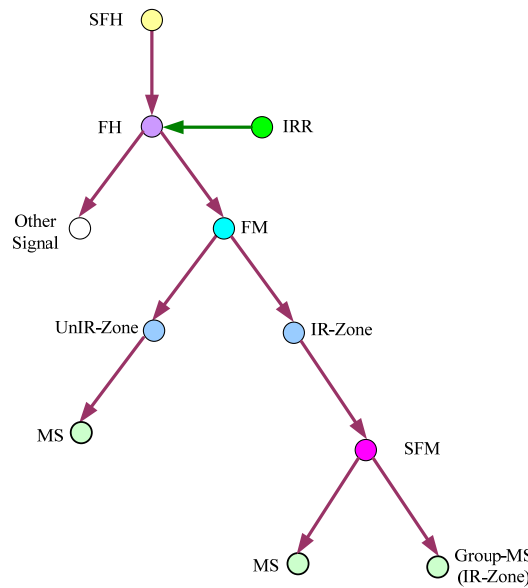

Fig. 2 Type A DL Control Flow for Interference Mitigation

## 2.2 Type B frame structure for control channels

Type B frame structure for control channels has the structure as shown in Fig. 3. Its DL control flow is shown in Fig. 4. There are five types of control channels in the frame and described in the following:

**2.2.1 Super Frame Header (SFH):** The SFH is used for the transmission of the information such as the synchronization, frequency reference, cell ID etc.

**2.2.2 Frame Header (FH):** The FH identifies which frame should activate an interference reducing region (IR-Region), and when an IR-Region is activated then the MS in this region will receive the interference

reducing service.

**2.2.3. Frame Map (FM):** The FM is used to designate which MSs in this IR-Region need the interference reducing service. The MS designated can be a group of MSs or a single MS. It gives MS the information of the region location, the proper pilot pattern and it also will provide the relative location information of the UL-Region.

**2.2.4 Sub-frame Map (SFM):** The SFM is used to designate which MSs in this IR-Region need the interference reducing service. The MS designated can be a group of MSs or a single MS. It gives MS the information it is in the interference reducing region, the proper pilot pattern and it also provides the relative location information of the MS request UL-Region.

**2.2.5 Interference Reducing Region (IR-Zone):** This zone is activated by the BS it can be divided into UL and DL IR-Zones. The zone's size and location are described in the FH, it also serves those MSs that need interference reducing services.

**2.2.6 Uplink-interference Reducing Request (UL-IRR):** the MS will send an interference reducing request in this frame and the BS will include this MS which sends this request in the IR-Region in the next DL frame.

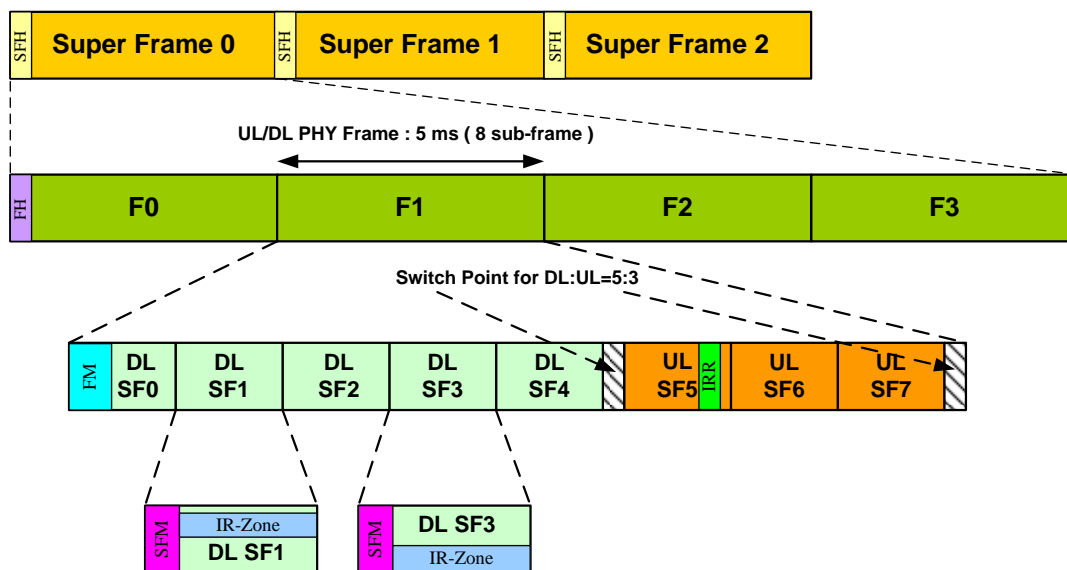

Fig. 3 Type B Frame Structure for Control Channels (FDM Mode)

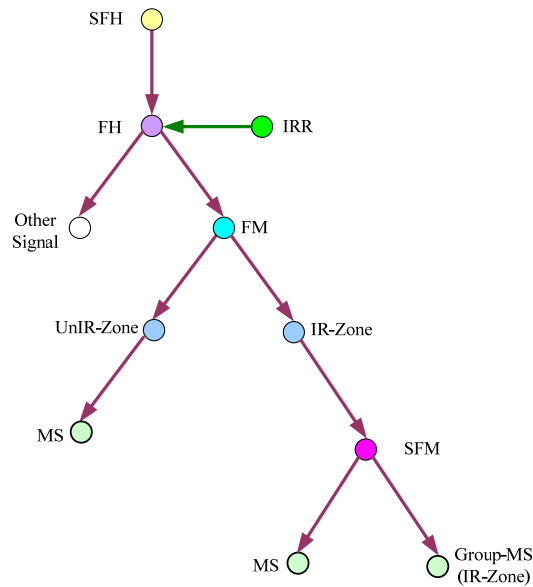

Fig. 4 Type B DL Control Flow for Interference Mitigation

### 2.3 Type C frame structure for control channels

Type C frame structure for control channels has the structure as shown in Fig. 5. Its DL control flow is shown in Fig. 6. There are five types of control channels in the frame and described in the following:

**2.3.1 Super Frame Header (SFH):** The SFH is used for the transmission of the information such as the synchronization, frequency reference, cell ID etc.

**2.3.2 Frame Header (FH):** The FH identifies which frame should activate an interference reducing zone (IR-Region), and when an IR-Region is activated then the MS in this region will receive the interference reducing service.

**2.3.3. FM (Frame Map):** This FM is used to designate MSs' locations in the sub-frame for those MSs are in the interference-reducing zone (IR-Zone). And the FM is used to designate which MSs in this IR-Zone need the interference reducing service. The MS designated can be a group of MSs or a single MS. It gives MS the information of the zone location, the proper pilot pattern and it also will provide the relative location information of the UL-Region.

**2.3.4 Interference Reducing Zone (IR-Zone):** This zone is activated by the BS it can be divided into UL and DL IR-Zones. The Zone's size and location are described in the FH it also serves those MSs that need interference reducing services.

**2.3.5 Uplink-interference Reducing Request (UL-IRR):** the MS will send an interference reducing request in this frame and the BS will include this MS which sends this request in the IR-Region in the next DL frame.

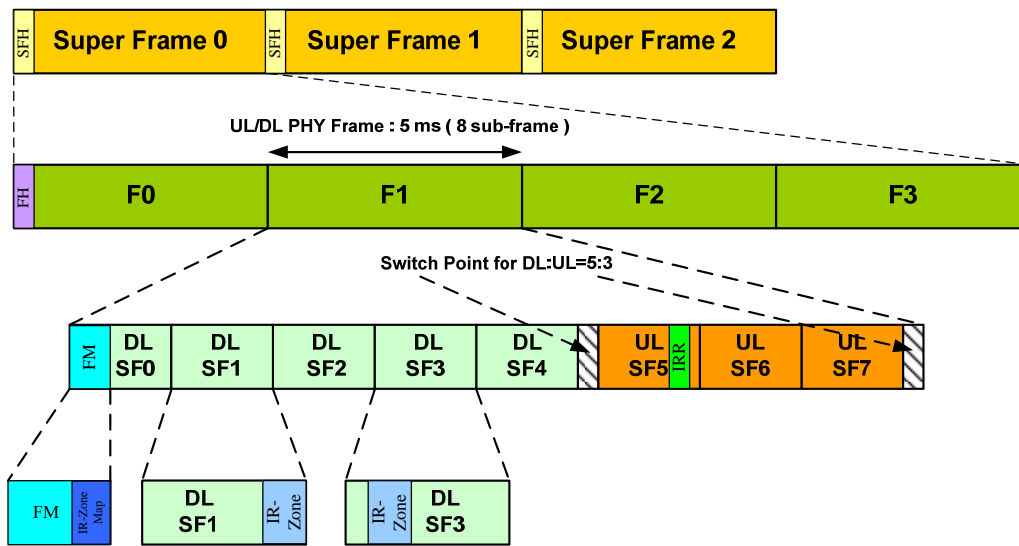

Fig. 5 Type C Frame Structure for Control Channels (TDM Mode)

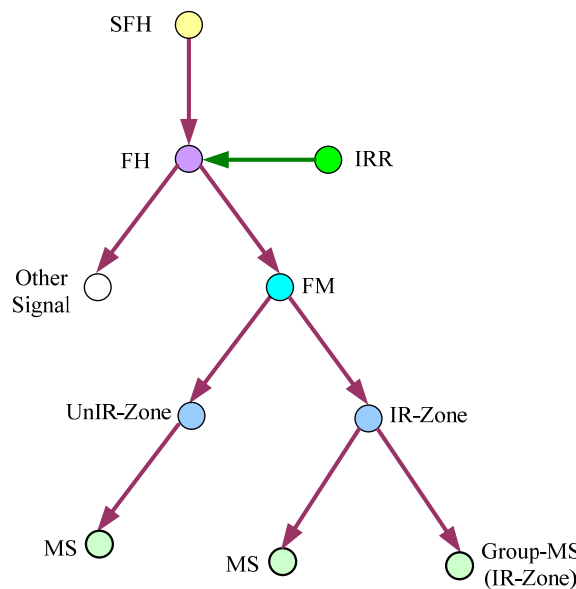

Fig. 6 Type C DL Control Flow for Interference Mitigation

### 2.4 Type D frame structure for control channels

Type D frame structure for control channels has the structure as shown in Fig. 7. Its DL control flow is shown in Fig. 6. There are five types of control channels in the frame and described in the following:

**2.4.1 Super Frame Header (SFH):** The SFH is used for the transmission of the information such as the synchronization, frequency reference, cell ID etc.

**2.4.2 FH (Frame Header):** the FH will identify which frame should activate an IR- Region (interference reducing Region), and when an IR- Region is activated then the MS in this zone will receive the interference reducing service.

**2.4.3 FM (Frame Map):** This FM is used to designate MSs' locations in the sub-frame for those MSs are in the interference-reducing zone (IR-Region). And the FM is used to designate which MSs in this IR-Region need the

interference reducing service. The MS designated can be a group of MSs or a single MS. It gives MS the information of the region location, the proper pilot pattern and it also will provide the relative location information of the UL- Region.

**2.4.4 Interference Reducing Region (IR-Zone):** This zone is activated by the BS it can be divided into UL and DL IR-Zones. The zone's size and location are described in the FH it also serves those MSs that need interference reducing services.

**2.4.5 Uplink-interference Reducing Request (UL-IRR):** the MS will send an interference reducing request in this frame and the BS will include this MS which sends this request in the IR-Region in the next DL frame.

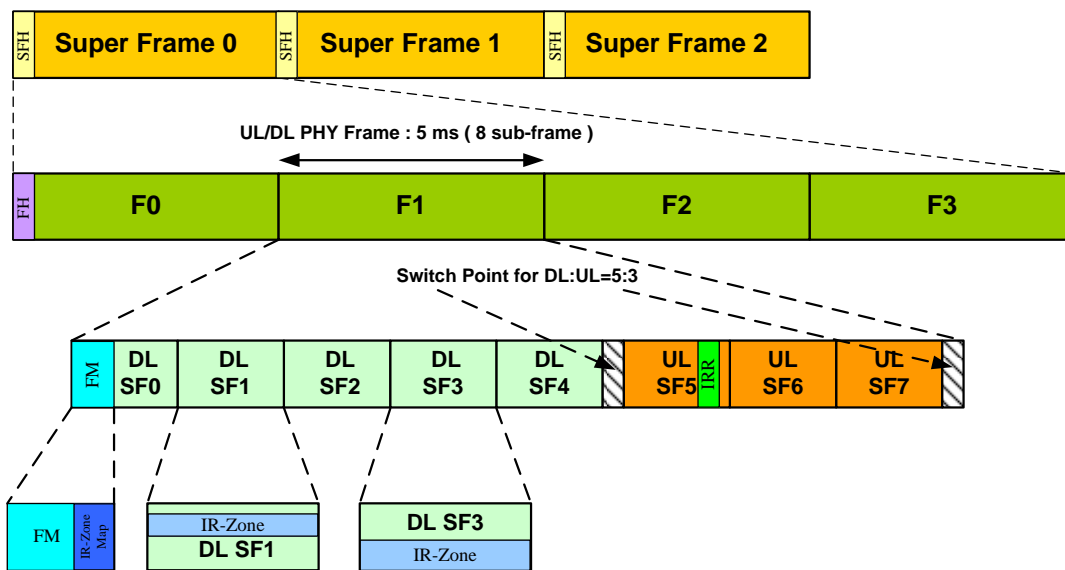

Fig. 7 Type D Frame Structure for Control Channels (FDM Mode)

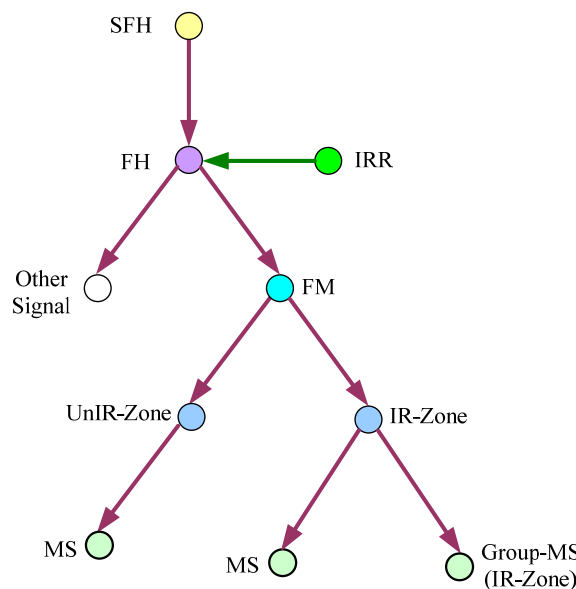

Fig. 8 Type D DL control flow for Interference Mitigation

### 3. Conclusion

With the IR-Zone concept introduced it will provide the interference reducing pilot patterns to the MSs through the UL/DL control channels to reduce the possible MSs' interference levels. When an MS's interference level is

high it will transmit an interference reducing request (IRR) to its serving BS, and when this BS receives this request it will check with other BSs and sends an IR-Zone notification and provides an interference reducing pilot pattern in the next frame for the MS to use in its later transmission. Consequently with the IR-Zone design concept it will reduce the interference level.

## 4. References

- [1] IEEE 802.16m System Requirements, IEEE 802.16m-07/002r4.  
 [2] The Draft IEEE 802.16m System Description Document, IEEE 802.16m-08/003r3

=====

*Text Proposal for the 'Interference Mitigation'*

=====Start of Proposed Text=====

### *XXX. PHY Control Channels for Interference Mitigation*

*The BS may coordinate with neighboring BSs to reduce interference at the cell edge by configuring IR-Zone and sending interference reducing pilot patterns within the zone. The IR-Zone may be configured by the BS in an unsolicited manner or may be requested by the MS. The IR-Zone is configured in either TDM or FDM across one or more subframes.*

There are six types of control channels in the frame and described in the following:

- **Super Frame Header (SFH):** The SFH is used for the transmission of the information such as the synchronization, frequency reference, cell ID etc.
- **Frame Header (FH):** The FH identifies which frame should activate an interference reducing zone (IR-Region), and when an IR-Region is activated then the MS in this region will receive the interference reducing service.
- **FM (Frame Map):** This FM is used to designate MSs' locations in the sub-frame for those MSs are in the interference-reducing zone (IR-Zone). And the FM is used to designate which MSs in this IR-Zone need the interference reducing service. The MS designated can be a group of MSs or a single MS. It gives MS the information of the zone location, the proper pilot pattern and it also will provide the relative location information of the UL-Region.
- **Sub-frame Map (SFM):** The SFM is used to designate which MSs in this IR-Zone need the interference reducing service. The MS designated can be a group of MSs or a single MS. It gives MS the information it is in the interference reducing zone, the proper pilot pattern and it also provides the relative location information of the MS request UL- Zone.
- **Interference Reducing Zone (IR-Zone):** This zone is activated by the BS it can be divided into UL and DL IR-Zones. The Zone's size and location are described in the FH it also serves those MSs that need interference reducing services.
- **Uplink-interference Reducing Request (UL-IRR):** the MS will send an interference reducing request in this frame and the BS will include this MS which sends this request in the IR-Region in the next DL frame.



Four examples of the frame structure with IR-Zone are depicted in the following figures with their associated DL control flows.

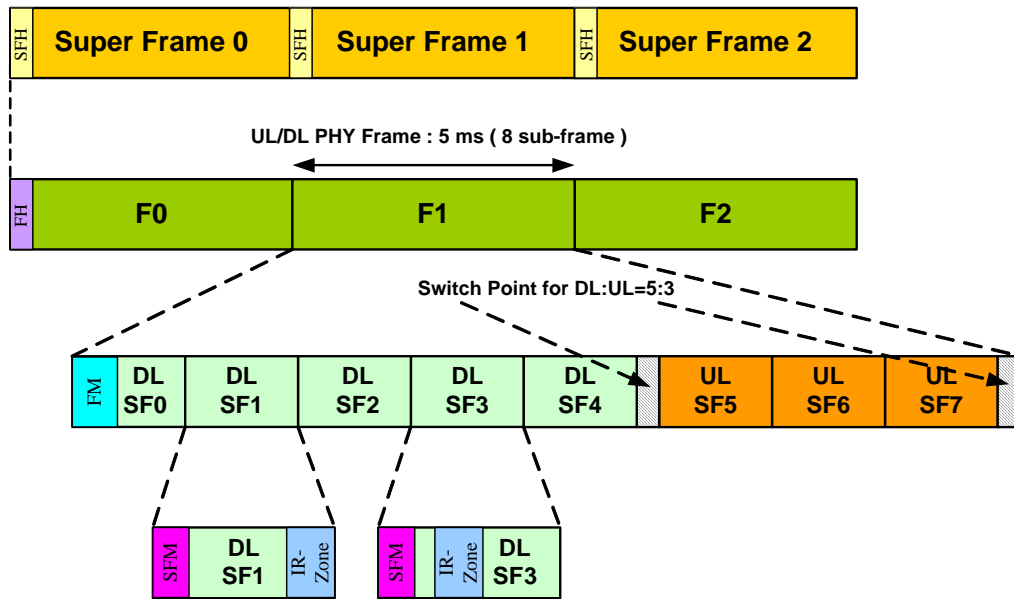

Fig.X.1 Type A Frame Structure for Control Channels (TDM Mode)

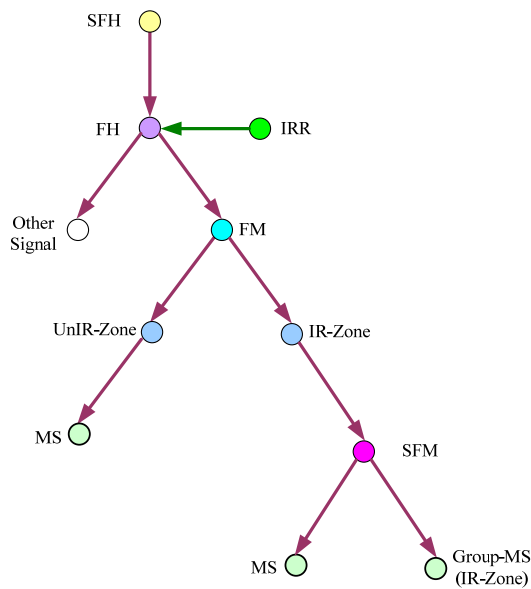

Fig.X.2 Type A DL Control Flow for Interference Mitigation

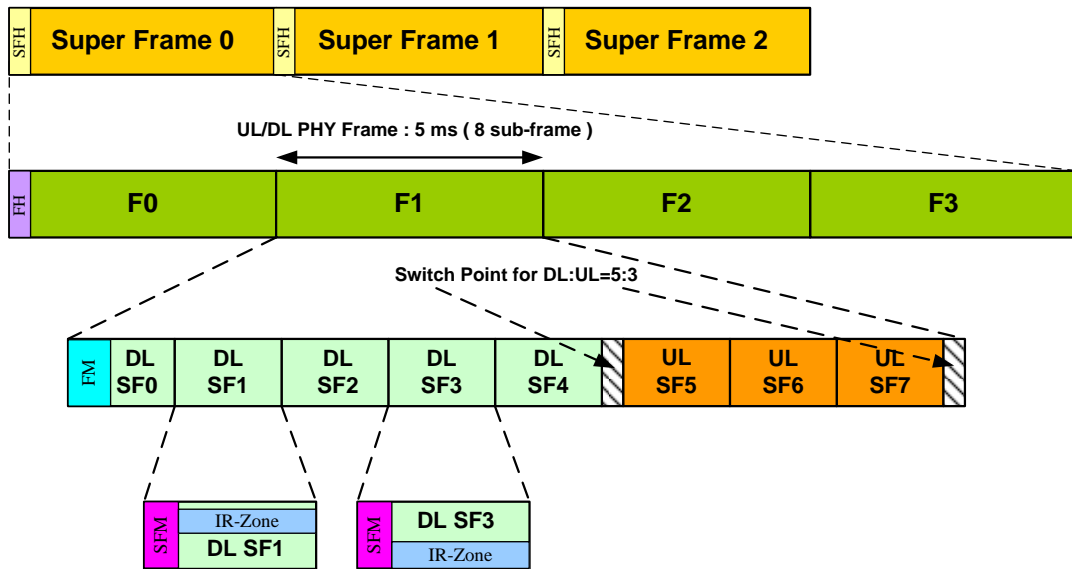

Fig.X.3 Type B Frame Structure for Control Channels (FDM Mode)

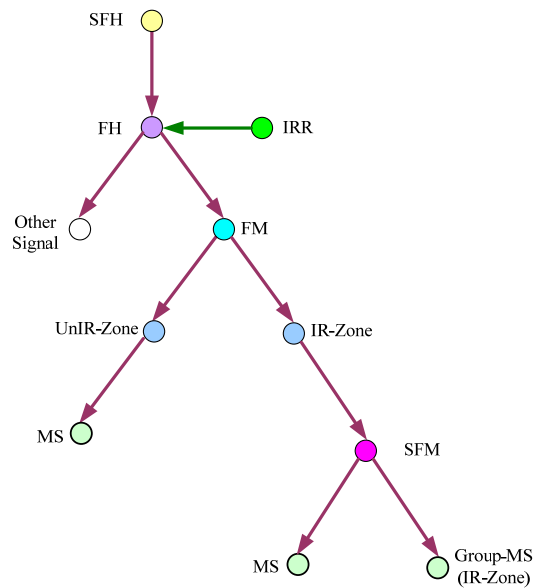

Fig.X.4 Type B DL Control Flow for Interference Mitigation

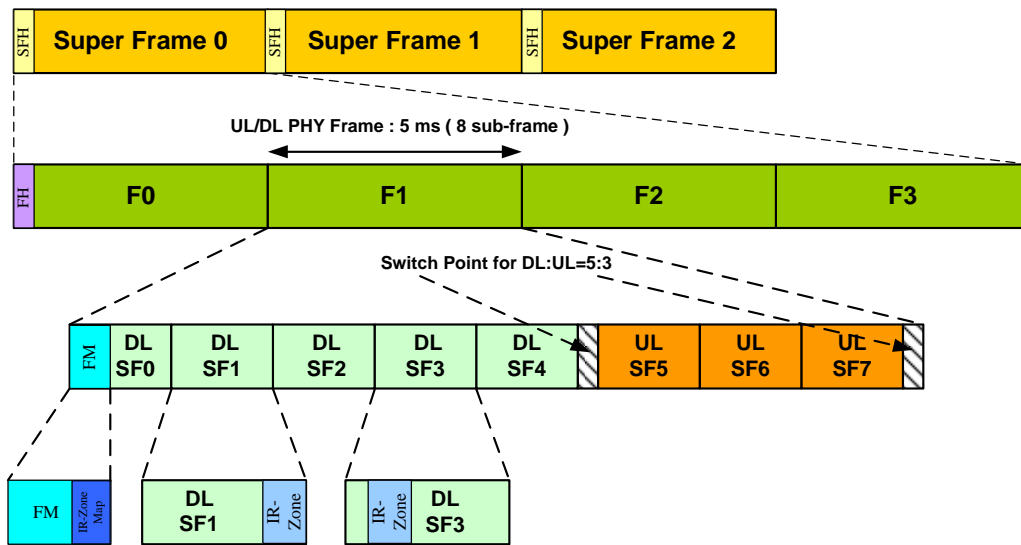

Fig.X.5 Type C Frame Structure for Control Channels (TDM Mode)

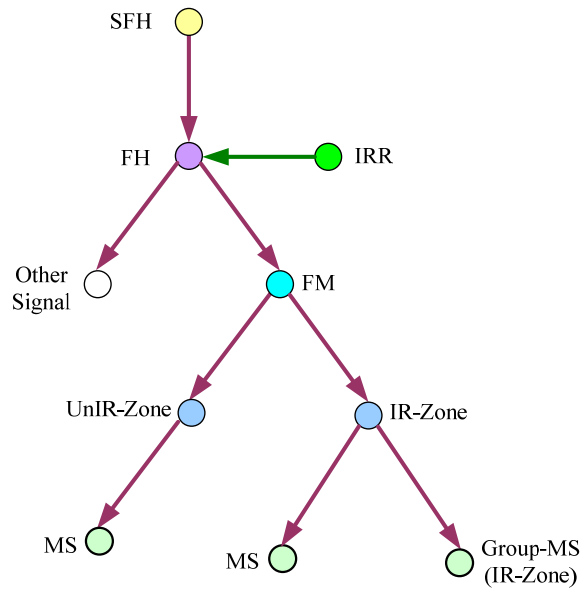

Fig.X.6 Type C DL Control Flow for Interference Mitigation

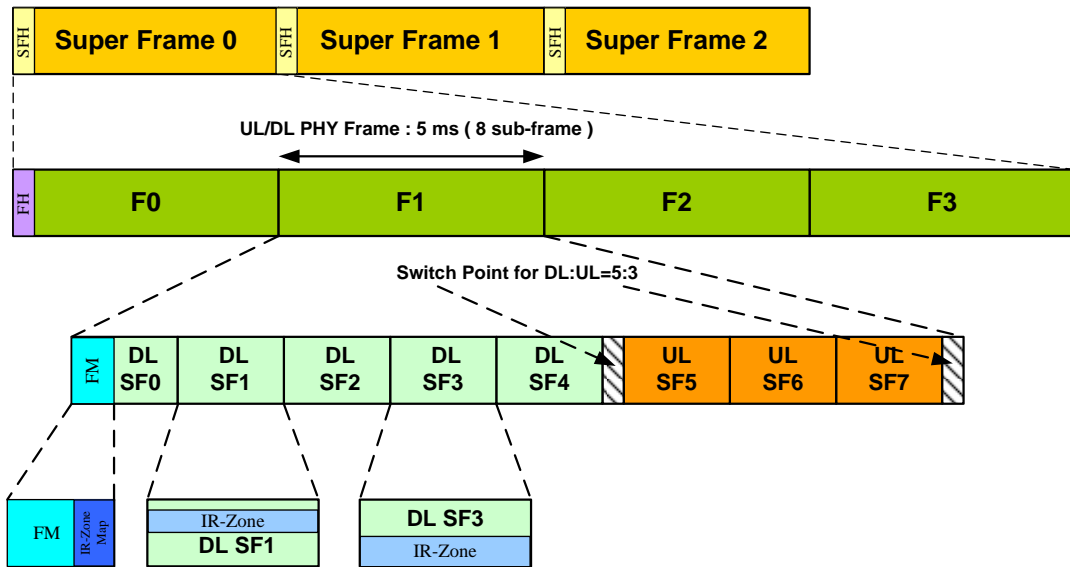

Fig.X.7 Type D Frame Structure for Control Channels (FDM Mode)

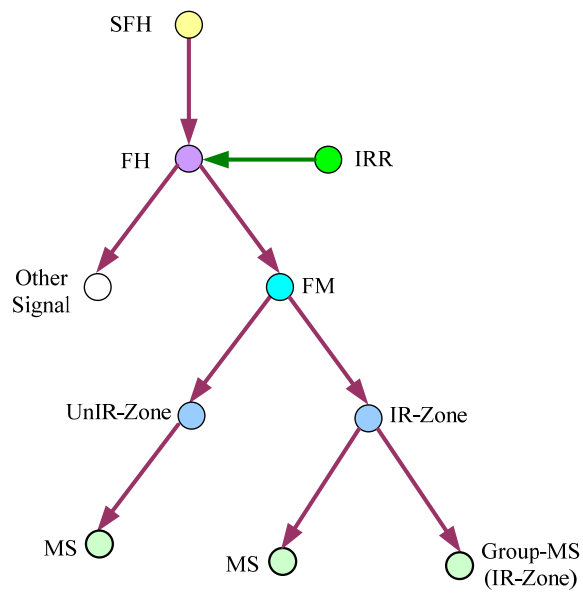

Fig.X.8 Type D DL Control Flow for Interference Mitigation

=====*End of Proposed Text*=====