

Project	IEEE 802.16 Broadband Wireless Access Working Group < http://ieee802.org/16 >	
Title	Correlated Scrambling Diversity Scheme for 802.16m E-MBS in SFN	
Date Submitted	2008-09-05	
Source(s)	Hsien-Wen Chang, Ming-Hung Cheng, Chorng-Ren Sheu, Ming-Chien Tseng, Chi-Fang (Richard) Li ITRI Kun-Yi Lin, Hsin-Piao Lin NTUT	Voice: +886 3 5915729 E-mail: seanchang@itri.org.tw
Re:	IEEE 802.16m-08/033 – Response to “Call for Contributions and Comments on Project 802.16m System Description Document (SDD)” on the topic of “PHY and MAC aspects of enhanced MBS”	
Abstract	We propose a correlated scrambling diversity scheme to improve the performance of IEEE 802.16m enhanced multicast/broadcast service (E-MBS) in single frequency network (SFN).	
Purpose	Discussion and adoption for 802.16m SDD	
Notice	<i>This document does not represent the agreed views of the IEEE 802.16 Working Group or any of its subgroups. It represents only the views of the participants listed in the “Source(s)” field above. It is offered as a basis for discussion. It is not binding on the contributor(s), who reserve(s) the right to add, amend or withdraw material contained herein.</i>	
Release	The contributor grants a free, irrevocable license to the IEEE to incorporate material contained in this contribution, and any modifications thereof, in the creation of an IEEE Standards publication; to copyright in the IEEE’s name any IEEE Standards publication even though it may include portions of this contribution; and at the IEEE’s sole discretion to permit others to reproduce in whole or in part the resulting IEEE Standards publication. The contributor also acknowledges and accepts that this contribution may be made public by IEEE 802.16.	
Patent Policy	The contributor is familiar with the IEEE-SA Patent Policy and Procedures: < http://standards.ieee.org/guides/bylaws/sect6-7.html#6 > and < http://standards.ieee.org/guides/opman/sect6.html#6.3 >. Further information is located at < http://standards.ieee.org/board/pat/pat-material.html > and < http://standards.ieee.org/board/pat >.	

Correlated Scrambling Diversity Scheme for 802.16m E-MBS in SFN

Hsien-Wen Chang, Ming-Hung Cheng, Chorng-Ren Sheu, Ming-Chien Tseng, Chi-Fang (Richard) Li

ITRI

Kun-Yi Lin, Hsin-Piao Lin

NTUT

Introduction

802.16m can be used as a digital broadcast mechanism through a Single Frequency Network (SFN). It's assumed that a simplex downlink is streamed to the user equipment (UE) through multiple base stations on the network, all using the same RF channel.

At the cell edge between transmitters in an SFN, it may happen that a receiver receives the same signal from two transmitters almost simultaneously. The tiny delay spread results in flat fading channel response with a wide coherent bandwidth. If signals from the two transmitters have phase reversed to one another, their destructive combination hence results in a totally faded flat channel. It is even worse that, for a static/quasi-static receiver, this terrible situation may continue for a long time relative to the interleaving length. Under such circumstances (flat and/or slow fading), a poor performance due to burst errors is expected. Therefore, it is important to 'create' diversity for solving the problem without affecting the receiver design.

In this contribution, we propose a novel correlated scrambling diversity (CSD) scheme [3] where the signal of each BS is independently scrambled, in both frequency- and time-dimensions, before transmission. For each BS, the phase rotations of contiguous subcarriers are correlated for composite channel response being continuous in frequency-dimension. On the other hand, the phases of contiguous symbols are rotated with controlled correlation depending on whether temporal interpolation is used for channel estimation or not. As a consequence, improved performance thanks to the diversity gain can be achieved with a simple channel estimation method by receivers.

Proposed Correlated Scrambling Scheme

System model

A typical SFN configuration is shown in Fig. 1. There is one transmitter at the center of each cell. Each receiver may receive line-of-sight (LOS) signals as well as echoes from the neighboring transmitters.

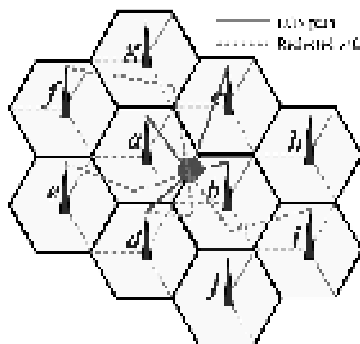

Fig. 1. SFN system configuration.

Fig. 2 shows the system model. It's assumed that M BSs transmit the same signal (OFDM symbols) through different channels which are then received and combined at the receiving antenna of a UE. Under a further

assumption that length of cyclic prefix (CP) of OFDM symbols is sufficiently large, the system model can thus

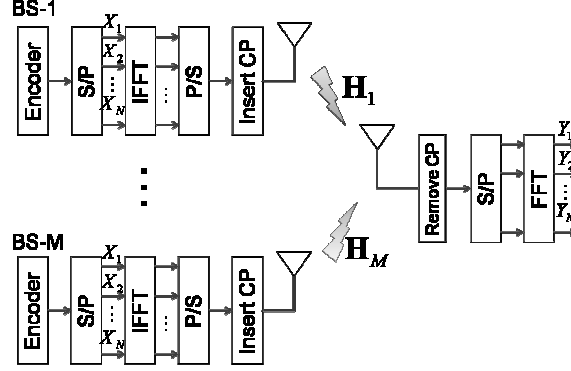

Fig. 2 System model

be derived as follows:

$$\mathbf{Y} = \sum_{m=1}^M \mathbf{H}_m \otimes \mathbf{X} + \mathbf{W} \quad (1)$$

where $\mathbf{Y} = [Y_1, Y_2, \dots, Y_N]^T$ is the received signal in N subcarriers of one OFDM symbol after N -point FFT operation, $\mathbf{H}_m = [H_{m,1}, H_{m,2}, \dots, H_{m,N}]^T$ includes N sub-channels from the m -th BS to the UE, $\mathbf{X} = [X_1, X_2, \dots, X_N]^T$ is the encoded signal to be transmitted, $\mathbf{W} = [W_1, W_2, \dots, W_N]^T$ denotes an additive Gaussian noise, and \otimes means element-wise product between vectors, \mathbf{A}^T means the transpose of a vector \mathbf{A} .

Eq. (1) can also be described as follows:

$$\mathbf{Y} = \mathbf{H}_{comp} \otimes \mathbf{X} + \mathbf{W}, \quad (2)$$

where \mathbf{H}_{comp} denotes the composite channel response of the M individual channels as:

$$\mathbf{H}_{comp} = \sum_{m=1}^M \mathbf{H}_m. \quad (3)$$

At the cell edge between transmitters, it may happen that the composite channel given by Eq. (3) becomes a totally faded flat channel due to tiny delay spread and destructive combination of various signal paths. A worse case is that, for a static/quasi-static receiver, this terrible situation may continue for a long time.

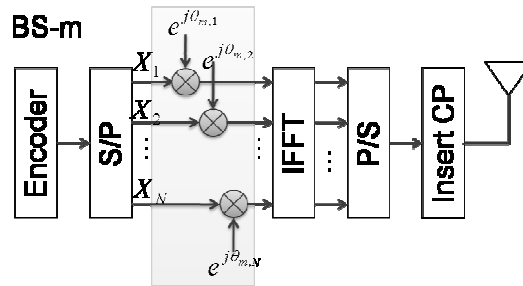

Fig. 3 The process of CSD

The proposed scheme

Fig. 3 shows the process of the proposed CSD scheme. Defining scrambling symbol as the value determining rotation of each subcarrier, the scrambling pattern is the way that scrambling symbols are organized along the

time- and frequency-dimension. In the proposed scheme, the scrambling symbols are correlated for contiguous subcarriers (frequency-dimension) and/or contiguous symbols (time-dimension). Corresponding to Fig. 3, the CSD can be described as follows:

$$\mathbf{Y}^{csd} = \sum_{m=1}^M \{ \mathbf{H}_m \otimes \mathbf{X}_m^{csd} \} + \mathbf{W} \quad (4)$$

where

$$\mathbf{X}_m^{csd} = \mathbf{D}_m^{csd} \otimes \mathbf{X}, \quad (5)$$

$$\mathbf{D}_m^{csd} = [e^{j\theta_{m,1}}, e^{j\theta_{m,2}}, \dots, e^{j\theta_{m,N}}]^T, \quad (6)$$

in which \mathbf{D}_m^{csd} is the scrambling pattern for m -th BS, and $e^{j\theta_{m,k}}$ is the scrambling symbol for k -th subcarrier of m -th BS.

Rewriting Eq. (4) in composite form as in Eq. (2) gives rise to

$$\mathbf{Y}^{csd} = \mathbf{H}_{comp}^{csd} \otimes \mathbf{X} + \mathbf{W}, \quad (7)$$

where

$$\mathbf{H}_{comp}^{csd} = \sum_{m=1}^M (\mathbf{H}_m \otimes \mathbf{D}_m^{csd}). \quad (8)$$

To clarify the characteristic of the proposed CSD scheme, assume the individual channels from the m -th BS to the UE are flat faded. The composite channel given by Eq. (8) can be further simplified as

$$\begin{aligned} \mathbf{H}_{comp}^{csd} &= \sum_{m=1}^M (H_m \cdot \mathbf{D}_m^{csd}) \\ &= \left[\sum_{m=1}^M H_m \cdot e^{j\theta_{m,1}}, \dots, \sum_{m=1}^M H_m \cdot e^{j\theta_{m,N}} \right]^T. \end{aligned} \quad (9)$$

where H_m is a scalar representing channel fading factor associated with m -th BS. Obviously, the composite channel is no longer flat but depends on the combination results whose feature is further determined by the scrambling pattern.

There are many ways to generate an appropriate scrambling pattern, as long as the coherent bandwidth of the pattern is larger than frequency spacing between contiguous pilots. The criterion is for the ease of channel estimation. One method is proposed here as an example. Let \mathbf{g} be an $N \times 1$ vector, and

$$\mathbf{g}_n = \begin{cases} \frac{1}{2} \cdot e^{j\theta_a}, & \text{for } n = 1, \\ 1 \cdot e^{j\theta_b}, & \text{for } n = 1 + d, \\ \frac{1}{2} \cdot e^{j\theta_c}, & \text{for } n = 1 + 2d, \\ 0, & \text{otherwise,} \end{cases} \quad (10)$$

where g_n denotes the n -th element of \mathbf{g} , $2d$ is path delay of the pattern generator, and $\theta_i, i = \{a, b, c\}$ is a random phase ranging between $\pm \pi$.

Next, let \mathbf{G} be the N -point DFT of \mathbf{g} . Then, the phases of the scrambling symbols can be chosen as

$$\begin{aligned} \Theta &= [\theta_1, \theta_2, \dots, \theta_N]^T \\ &= (|\mathbf{G}| - |\mathbf{G}|_{\min}) \cdot \frac{2\pi}{|\mathbf{G}|_{\max} - |\mathbf{G}|_{\min}}, \end{aligned} \quad (11)$$

where $|\mathbf{G}|_{\max}$ and $|\mathbf{G}|_{\min}$ means the maximum and minimum value of $|\mathbf{G}|$, respectively. By choosing an appropriate path delay $2d$, the scrambling symbols expected to be strongly correlated for contiguous subcarriers can be obtained. No prior information about the scrambling patterns is needed by receivers that can estimate the

composite channel given by Eq. (8) via a typical pilot-based linear interpolation approach.

Simulation Results

Computer simulation is performed to evaluate the proposed CSD scheme. The simulation parameters are described in Table 1. In this simulation, the performances of coded bit error rate (BER) versus the required signal to noise ratios (SNR) are evaluated. The comparison between the proposed CSD scheme (as shown in Fig. 3) and no diversity scheme (as shown in Fig. 2) will be shown in the following simulation results.

Table 1 Parameters of Link-level Simulation

Carrier frequency	2.5GHz
Channel bandwidth	10MHz
FFT size	1,024
Cyclic prefix	1/8
Subcarrier permutation	PUSC
FEC data block size	480 bits
Modulation and code rate	QPSK 1/2
Channel coding	Convolutional turbo code (CTC)
Channel	ITU Vehicular A or single-path
User mobility	30km/hr
Channel estimation	Cluster-based linear interpolation
Number of cells	2
CSD path delay	10

Single-path channel model is considered in Fig.4 and Fig. 5. Fig. 4 shows the BER curves of proposed scheme and no diversity scheme using ideal channel estimation, i.e., channel state information (CSI) is known at the UE. Under the impractical assumption of known CSI, proposed scheme provides about 8 dB diversity gain to the system when BER equals 10^{-3} .

Fig. 5 shows the BER curves of proposed scheme and no diversity scheme using cluster-based linear interpolation channel estimation. It can be seen that when imperfect channel estimation loss is taken into account, the proposed CSD scheme provides more than 10 dB gain to the system when BER equals 10^{-3} .

For more realistic Vehicular A (VA) channel model, the corresponding results using the same channel estimation scheme are shown in Fig. 6. It can be seen that, for $\text{BER}=10^{-3}$, the proposed CSD scheme still exhibits 4dB gain to the system without any diversity scheme.

Conclusion

In an SFN configuration, UE at cell edges experiencing flat and/or slow fading cannot operate well. We have presented a novel correlated scrambling diversity scheme to overcome this problem. Through computer simulations, the proposed CSD scheme has been shown to provide significant diversity gain compared to the original system.

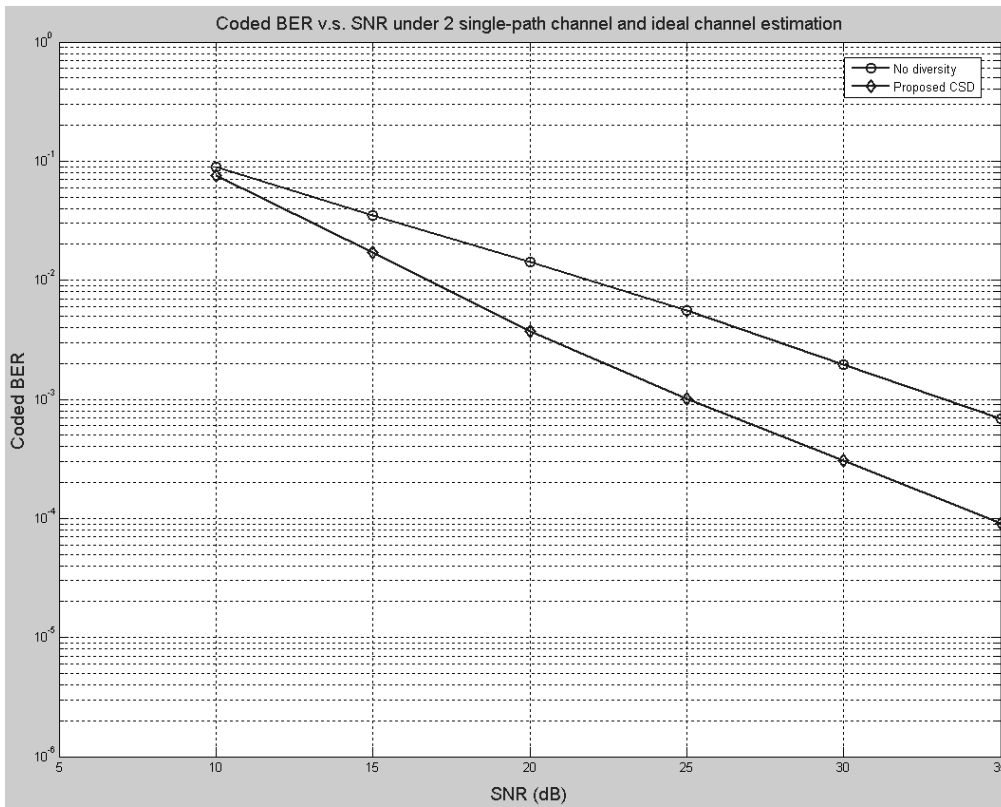

Fig. 4 The BER curve of proposed scheme using ideal channel estimation under single-path channel model.

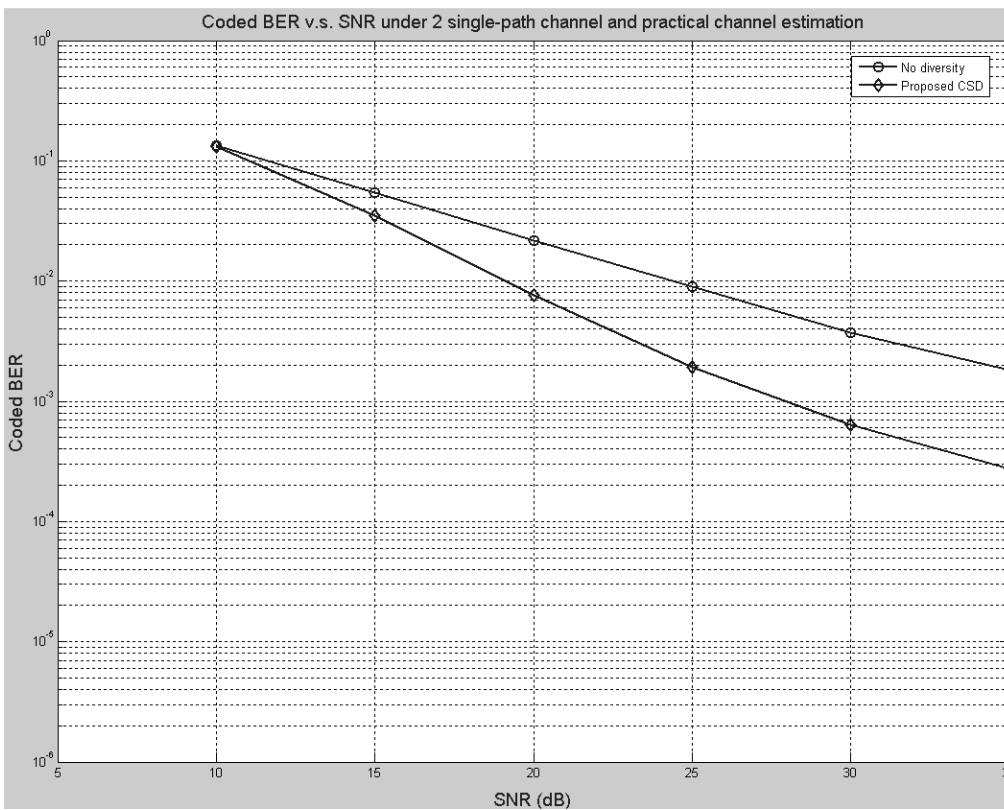

Fig. 5 The BER curve of proposed scheme using practical channel estimation under single-path channel model.

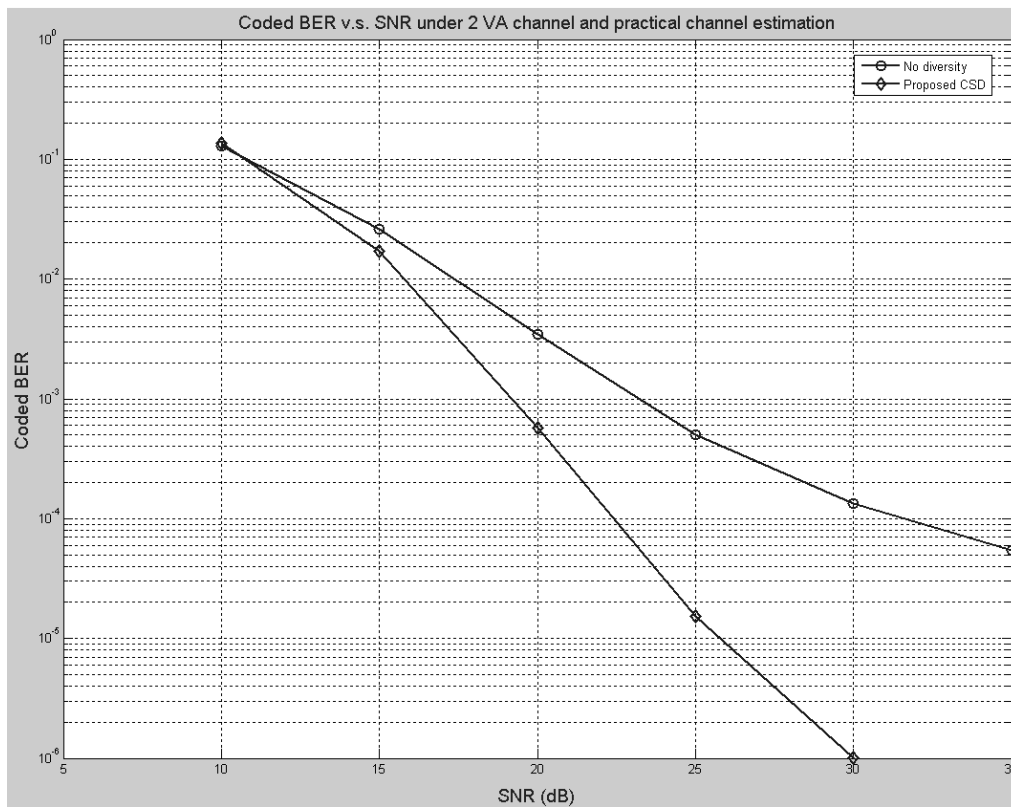

Fig. 6 The BER curve of proposed scheme using practical channel estimation under VA channel model.

Reference

- [1] IEEE 802.16m-07/002r4, "IEEE 802.16m System Requirements"
- [2] IEEE Draft P802.16Rev2/D2, "Part 16: Air interface for broadband wireless access systems," December, 2007
- [3] H.-W. Chang, C.-R. Sheu, M.-C. Tseng, and C.-Y. Chen, "Correlated scrambling scheme for time-frequency diversity in OFDM single-frequency-network systems," to be published in Proc. IEEE Vehicular Technology Conference 2008-Fall (VTC'F08), Calgary, Canada, Sep. 2008.

Proposed Text

----- Start of the proposed text -----

15 Support for Enhanced Multicast Broadcast Service

15.x Correlated Scrambling Diversity Scheme

Correlated scrambling diversity (CSD) scheme can be considered for 802.16m systems. Each base station generates its correlated scrambling pattern independently to others and applies it to the transmitted signal as follows.

$$\mathbf{X}_m^{csd} = \mathbf{D}_m^{csd} \otimes \mathbf{X}$$

where $\mathbf{X} = [X_1, X_2, \dots, X_N]^T$ is the encoded signal to be transmitted, and $\mathbf{D}_m^{csd} = [e^{j\theta_{m,1}}, e^{j\theta_{m,2}}, \dots, e^{j\theta_{m,N}}]^T$ is the scrambling pattern for m -th BS, $e^{j\theta_{m,k}}$ is the scrambling symbol for k -th subcarrier of m -th BS.

Scrambling patterns can be generated as follows. Let \mathbf{g} be an $N \times 1$ vector, and

$$\mathbf{g}_n = \begin{cases} \frac{1}{2} \cdot e^{j\theta_a}, & \text{for } n = 1, \\ 1 \cdot e^{j\theta_b}, & \text{for } n = 1 + d, \\ \frac{1}{2} \cdot e^{j\theta_c}, & \text{for } n = 1 + 2d, \\ 0, & \text{otherwise,} \end{cases}$$

where g_n denotes the n -th element of \mathbf{g} , $2d$ is path delay of the pattern generator, and $\theta_i, i = \{a, b, c\}$ is a random phase ranging between $\pm \pi$.

Next, let \mathbf{G} be the N -point DFT of \mathbf{g} . Then, the phases of the scrambling symbols can be chosen as

$$\begin{aligned} \boldsymbol{\Theta} &= [\theta_1, \theta_2, \dots, \theta_N]^T \\ &= (|\mathbf{G}| - |\mathbf{G}|_{\min}) \cdot \frac{2\pi}{|\mathbf{G}|_{\max} - |\mathbf{G}|_{\min}}, \end{aligned}$$

where $|\mathbf{G}|_{\max}$ and $|\mathbf{G}|_{\min}$ means the maximum and minimum value of $|\mathbf{G}|$, respectively.

The coherent bandwidth of the pattern, in terms of subcarrier spacing, is proportional to $\frac{N}{2d}$, and should be larger than frequency spacing between contiguous pilots for the ease of channel estimation.

----- End of the proposed text -----