

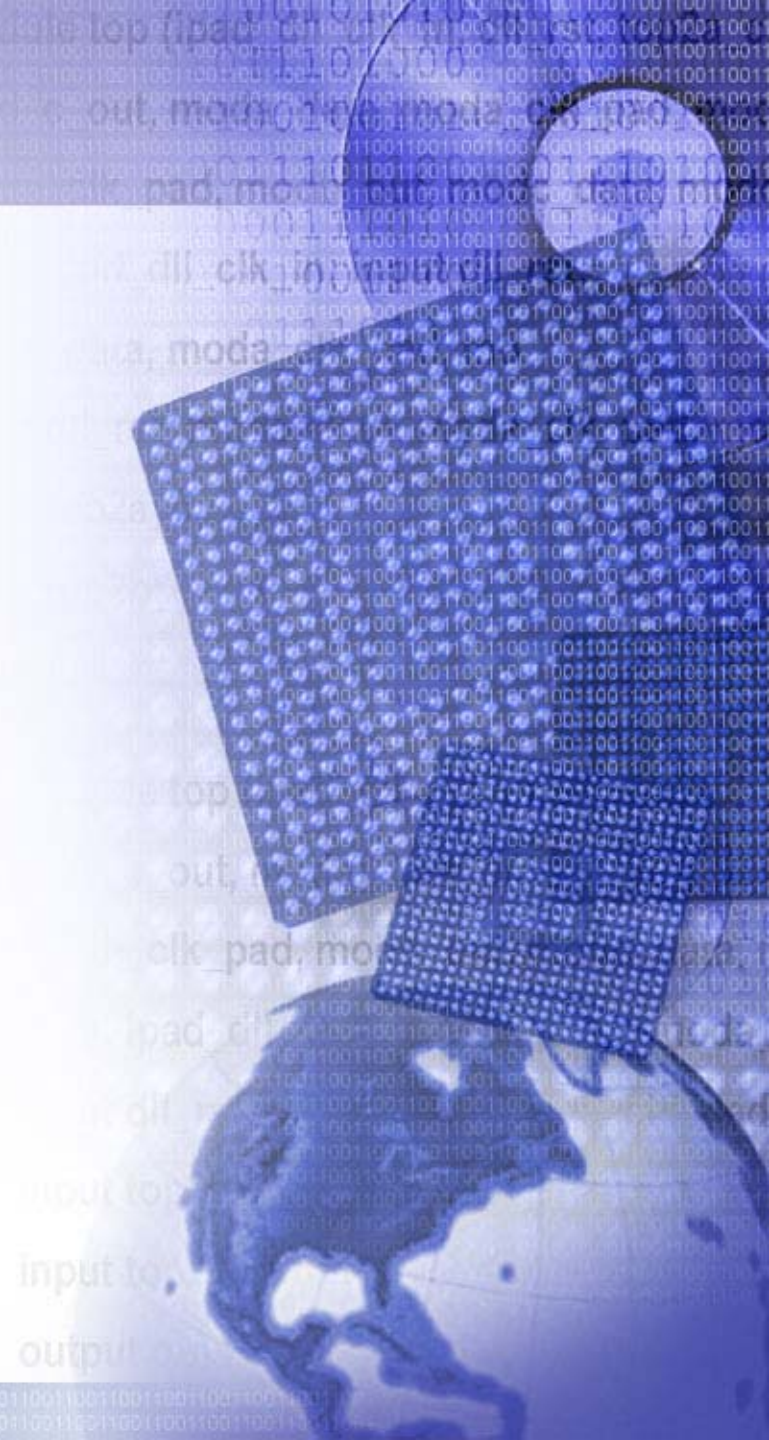

CAUI-4 options

Tom Palkert

Xilinx



System vendor problem

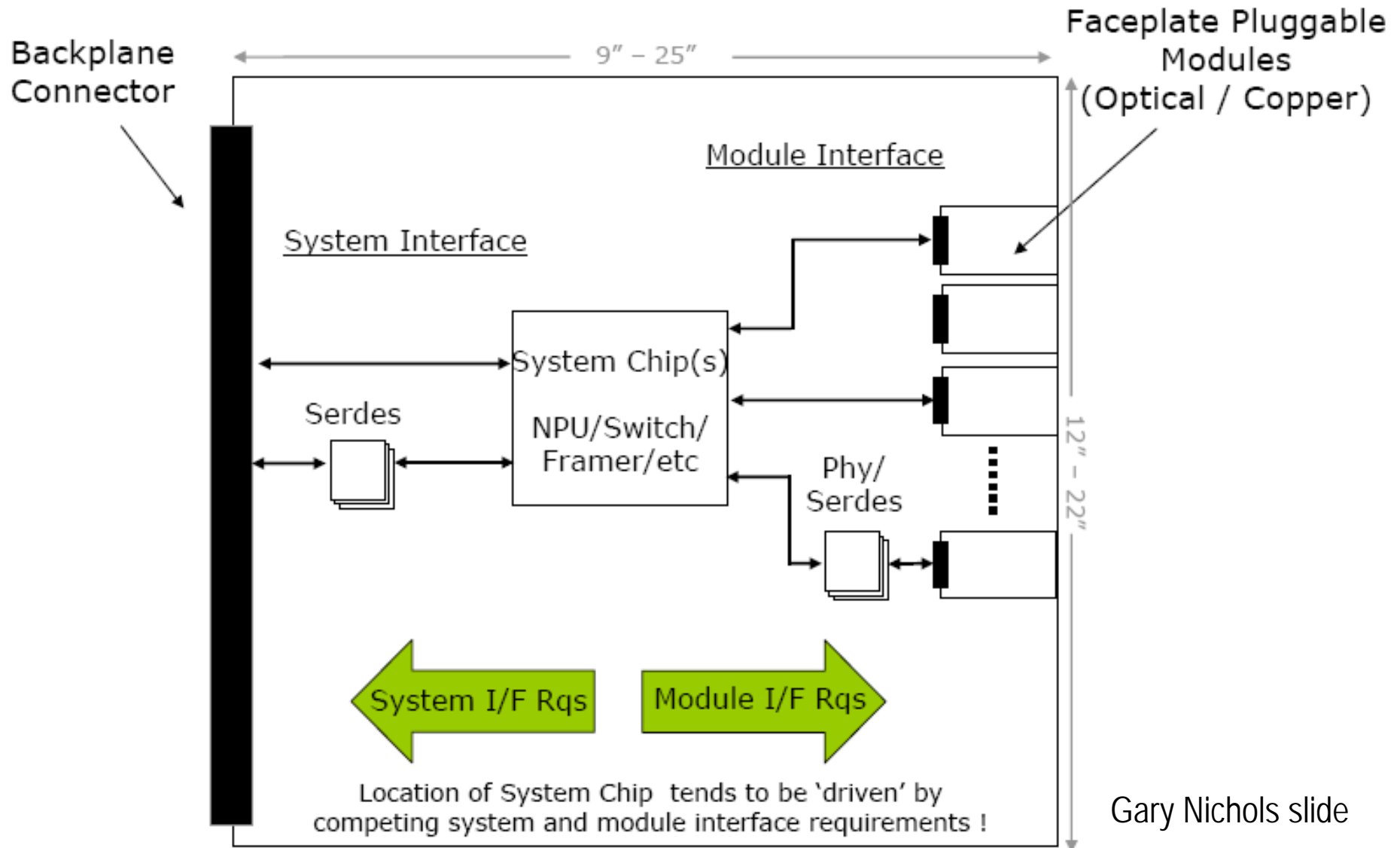

Gary Nichols slide

100G electrical interface system requirements

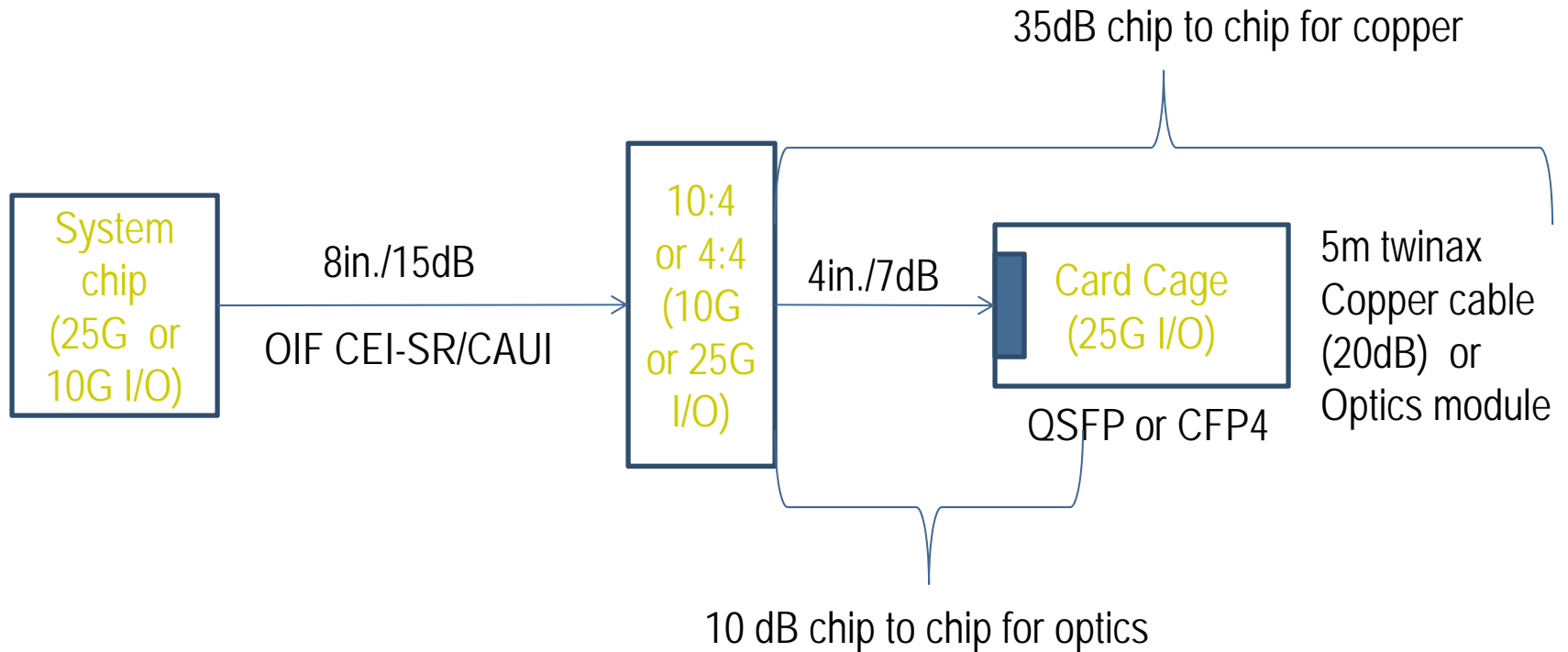

Issues and possible solutions

- Need common port for copper and optics
 - Use bj copper port host budget for CAUI4
 - Module SERDES power needs to be minimized
 - OIF CEI-28G-VSR solves the issue
- Need longer reaches for lower cost/power longer term solutions
 - Define an asymmetric link to maintain module compatibility and reduce power
 - Keep power down in module SERDES
 - LR macro in Host ASIC, VSR macro in module?
- Copper will not work in longer reach host ports
 - ?

Proposed CAUI4

CAUI4/VSR SERDES

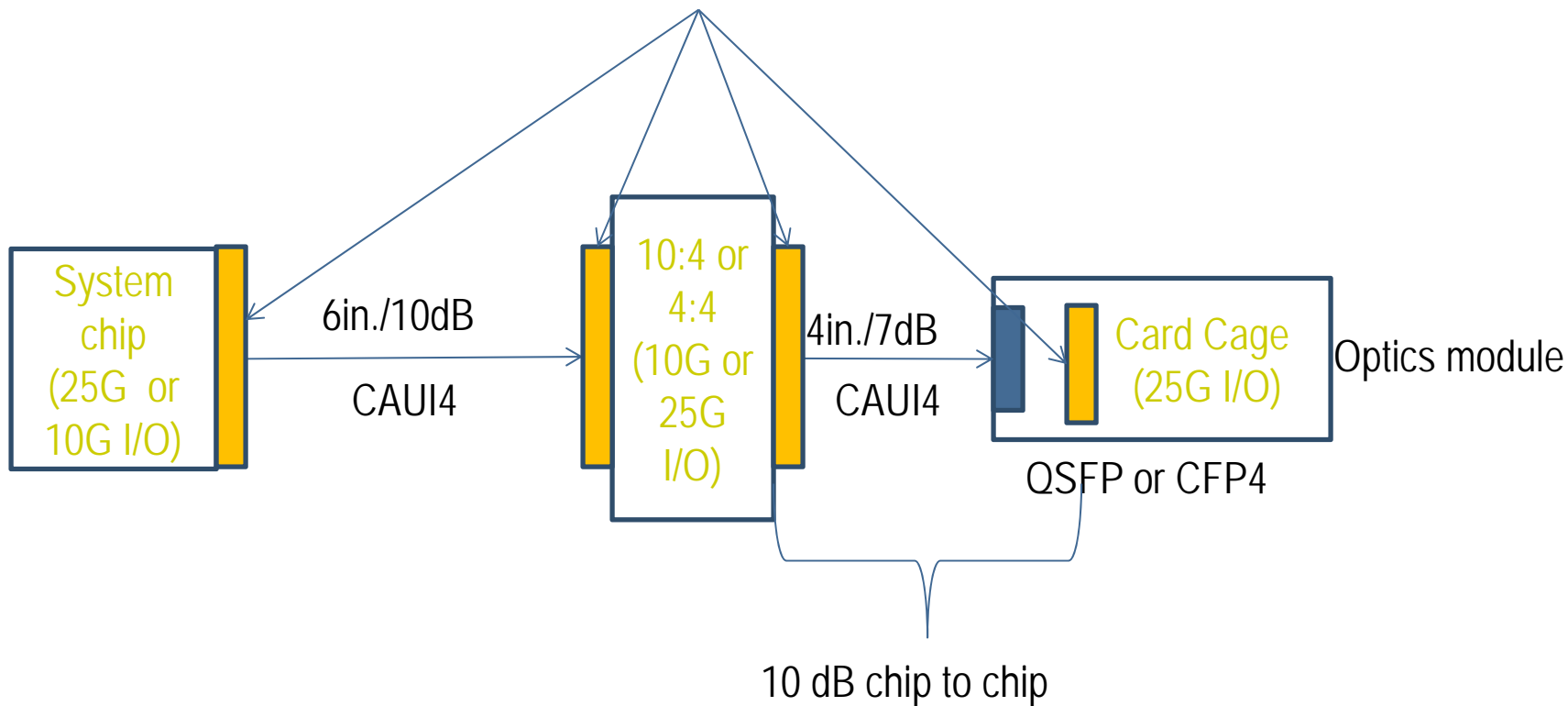

Proposed CAUI4e

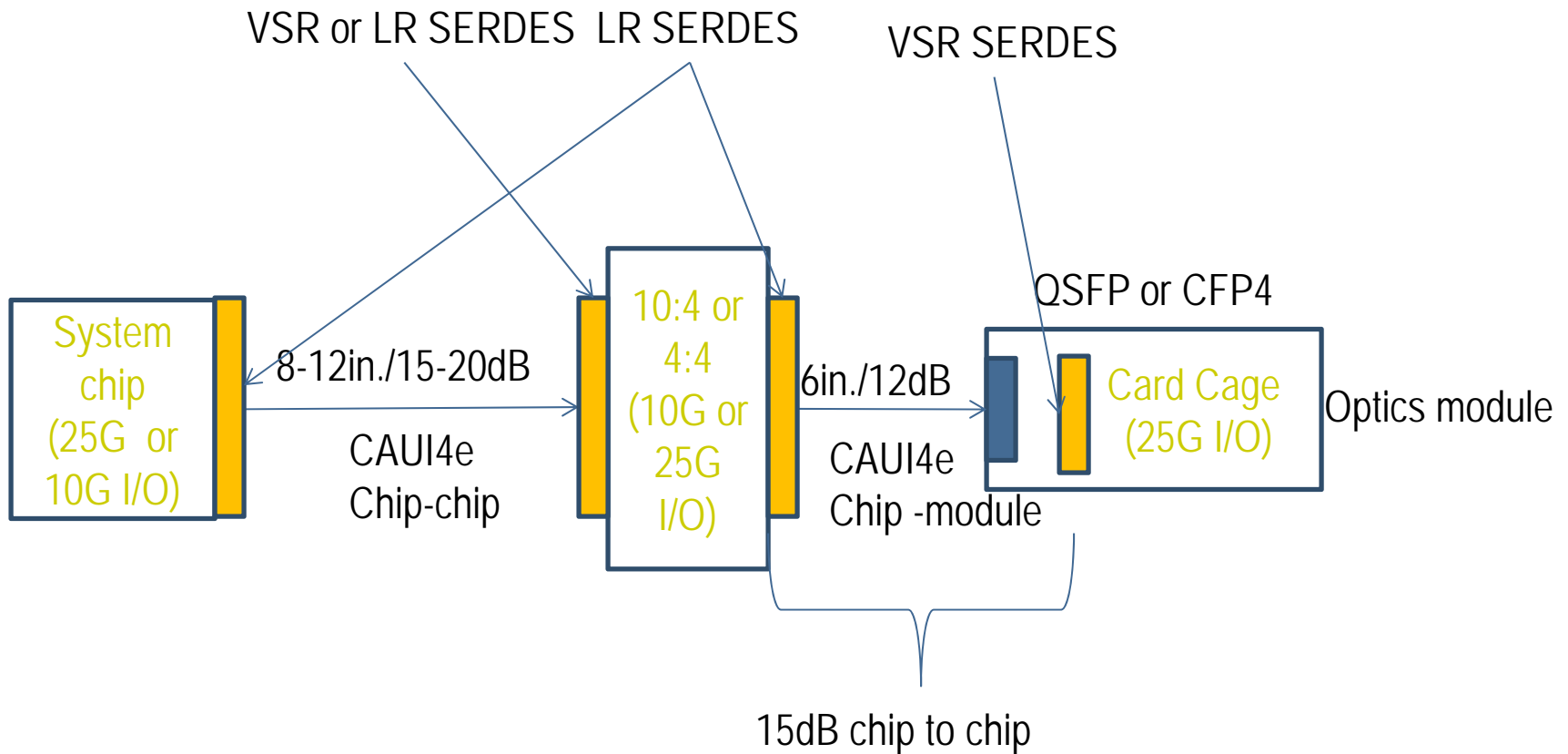

Conclusion

- Have a nice day

