



Canova Tech

The Art of Silicon Sculpting

PIERGIORGIO BERUTO
GIAN MARCO BO

IEEE802.3cg TF

Backplane Simulations

January 24th, 2018

Stripline, Multidrop

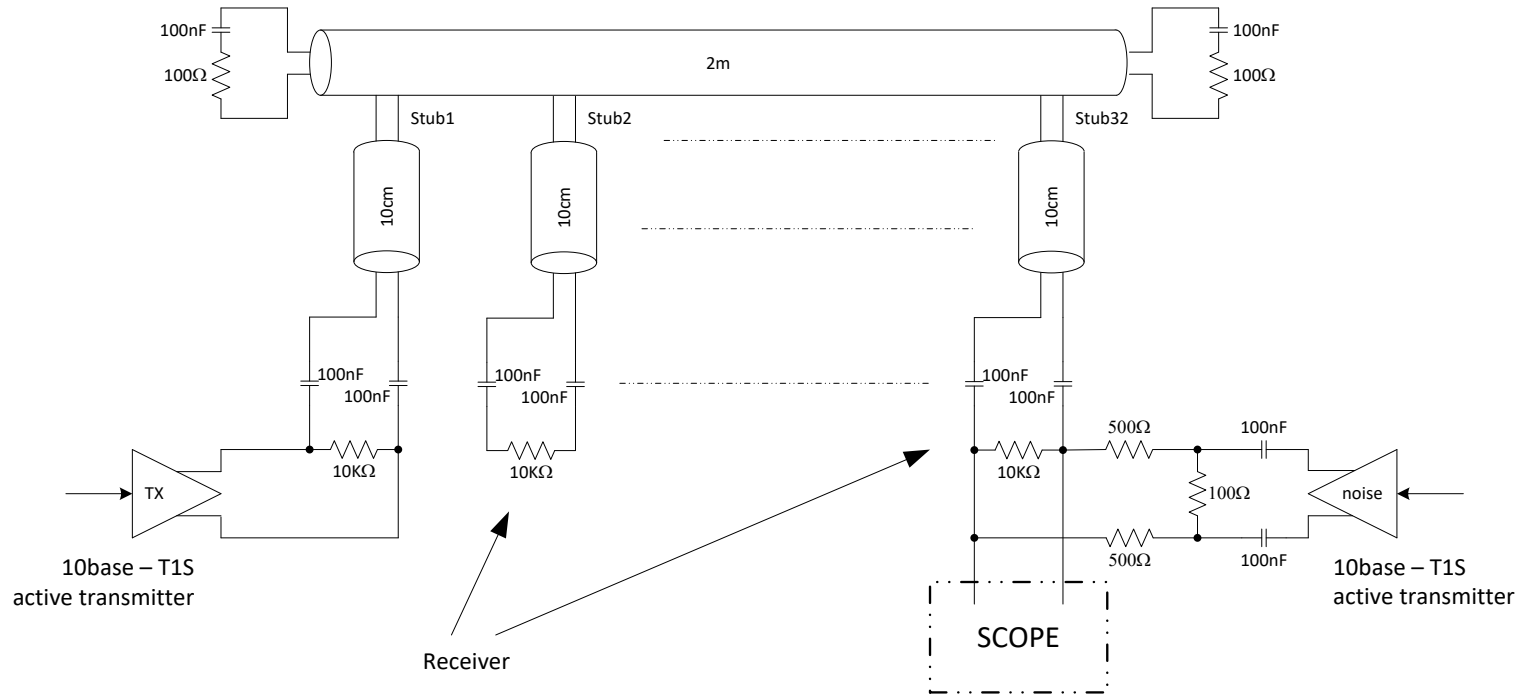

- 2 meters stripline, 32 nodes
- $100\Omega \pm 1\%$ line termination resistance
- $50\Omega \pm 20\%$ transmitters (high-Z when silent)
- Alien Crosstalk Noise
 - T1S transmitter, $\sim 50\text{mVpp}$ @ 1Vpp TX

Mixing segment with 50mVpp Alien Noise

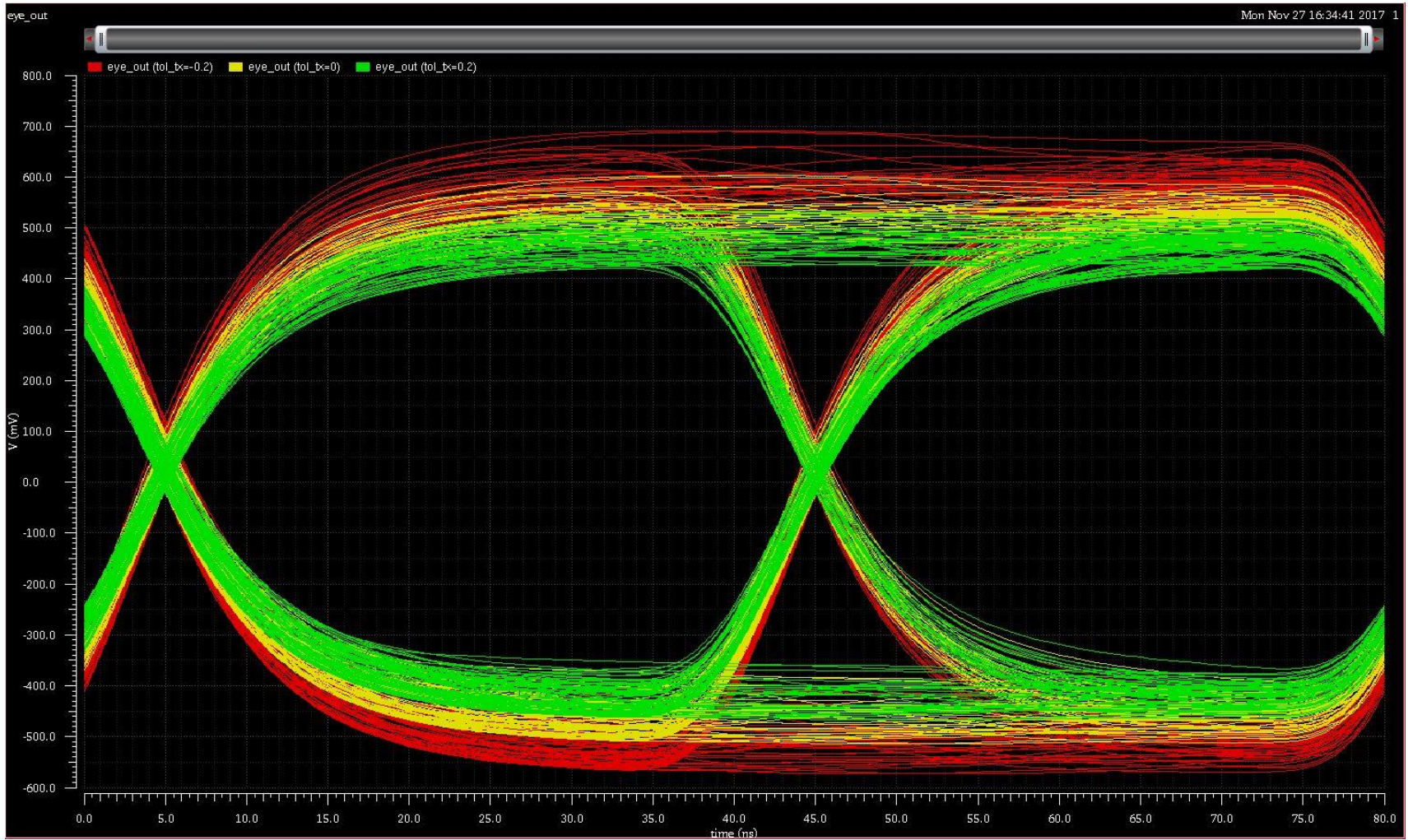

Microstrip, Multidrop

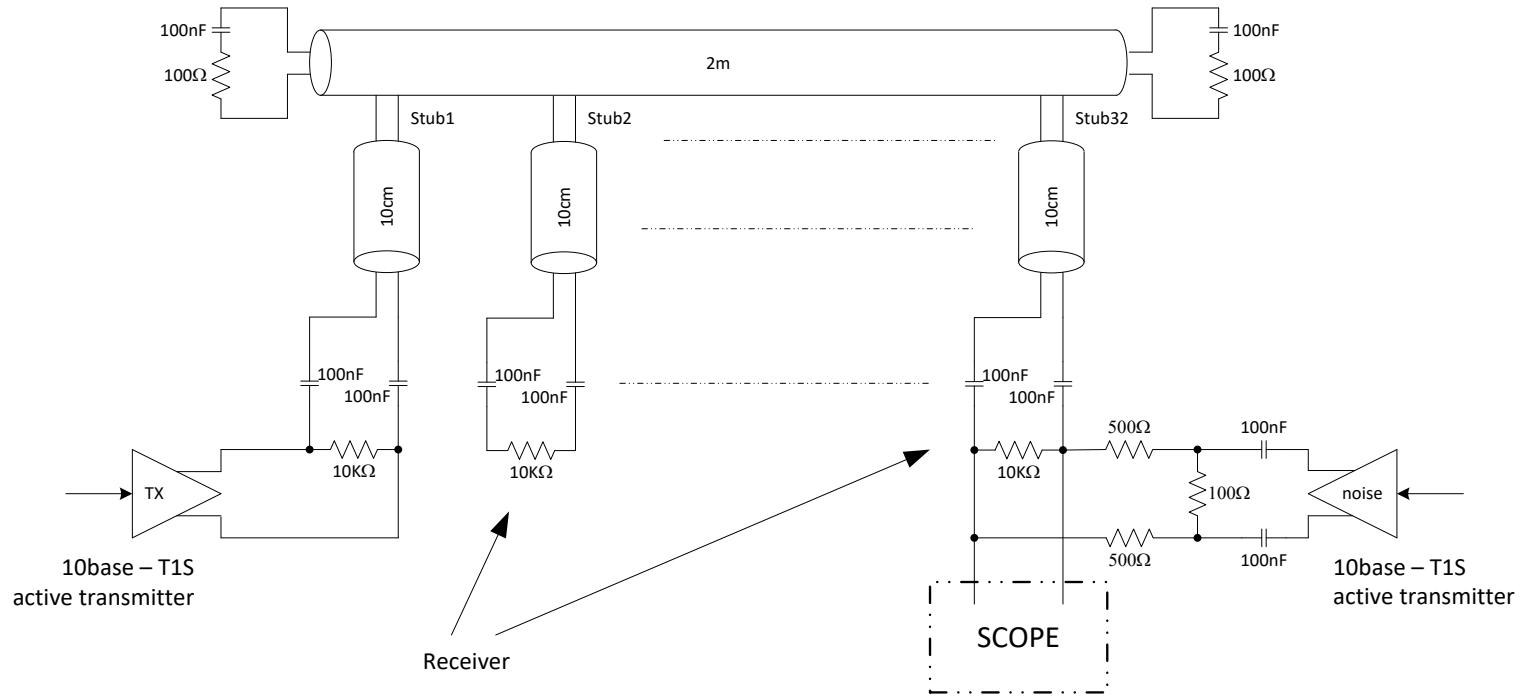

- 2 meters microstrip, 32 nodes
- $100\Omega \pm 1\%$ line termination resistance
- $50\Omega \pm 20\%$ transmitters (high-Z when silent)
- Alien Crosstalk Noise
 - T1S transmitter, $\sim 50\text{mVpp}$ when 1Vpp TX

Mixing segment with 50mVpp Alien Noise

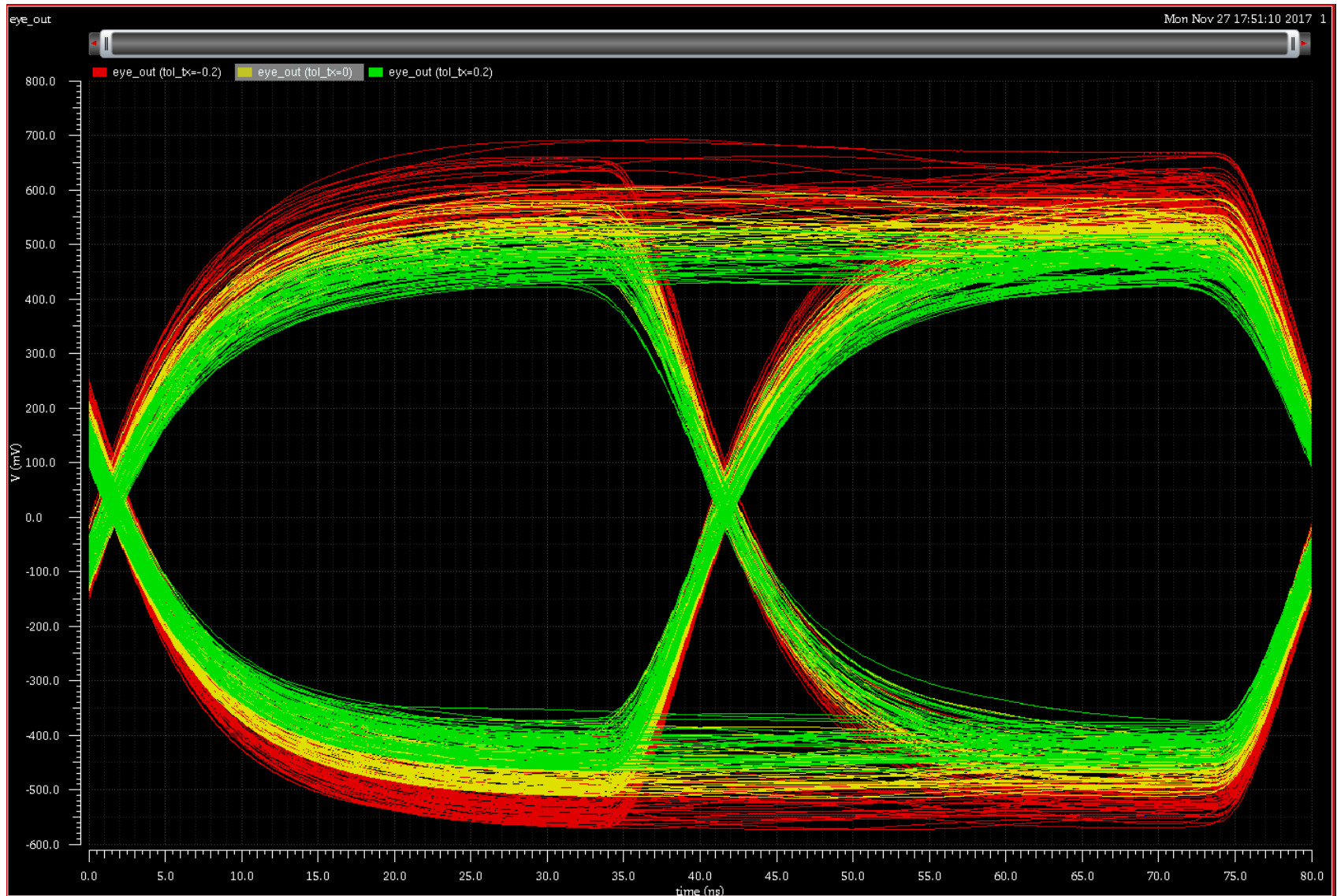

Stripline, Point to Point

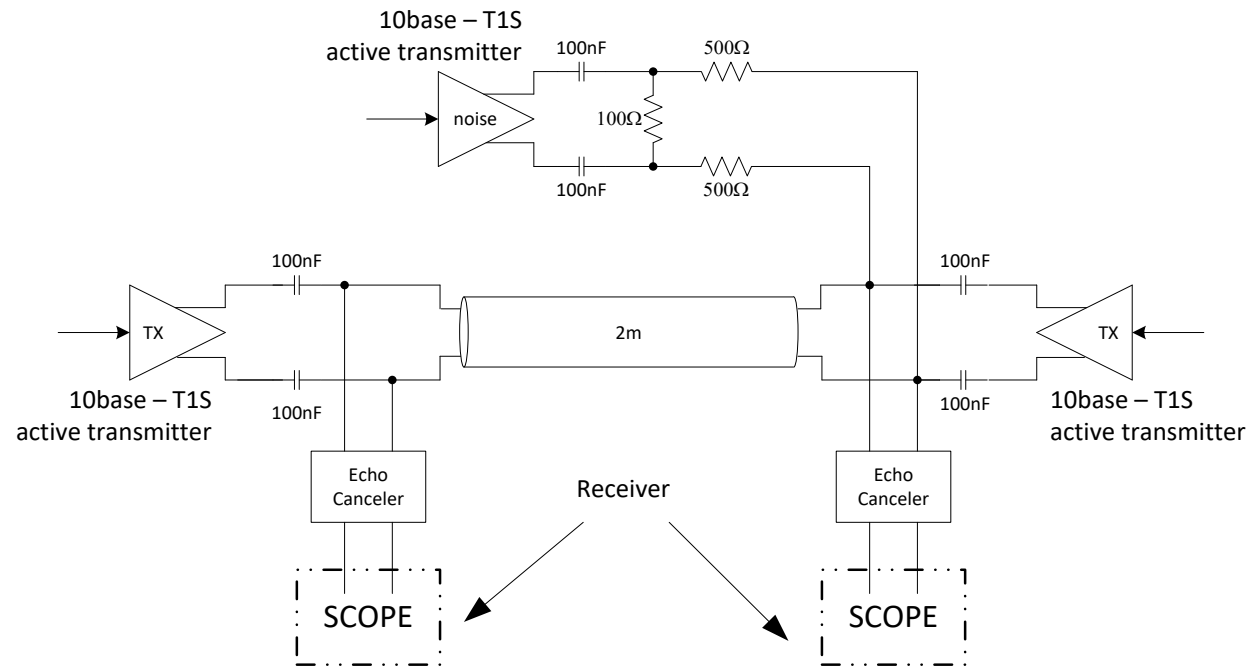

- 2 meters stripline
- $100\Omega \pm 20\%$ transmitters
- Full duplex
- Echo cancellation
- Alien Crosstalk Noise
 - T1S transmitter, $\sim 50\text{mVpp}$ when 1Vpp TX

Link segment Full Duplex with 50mVpp Alien Noise

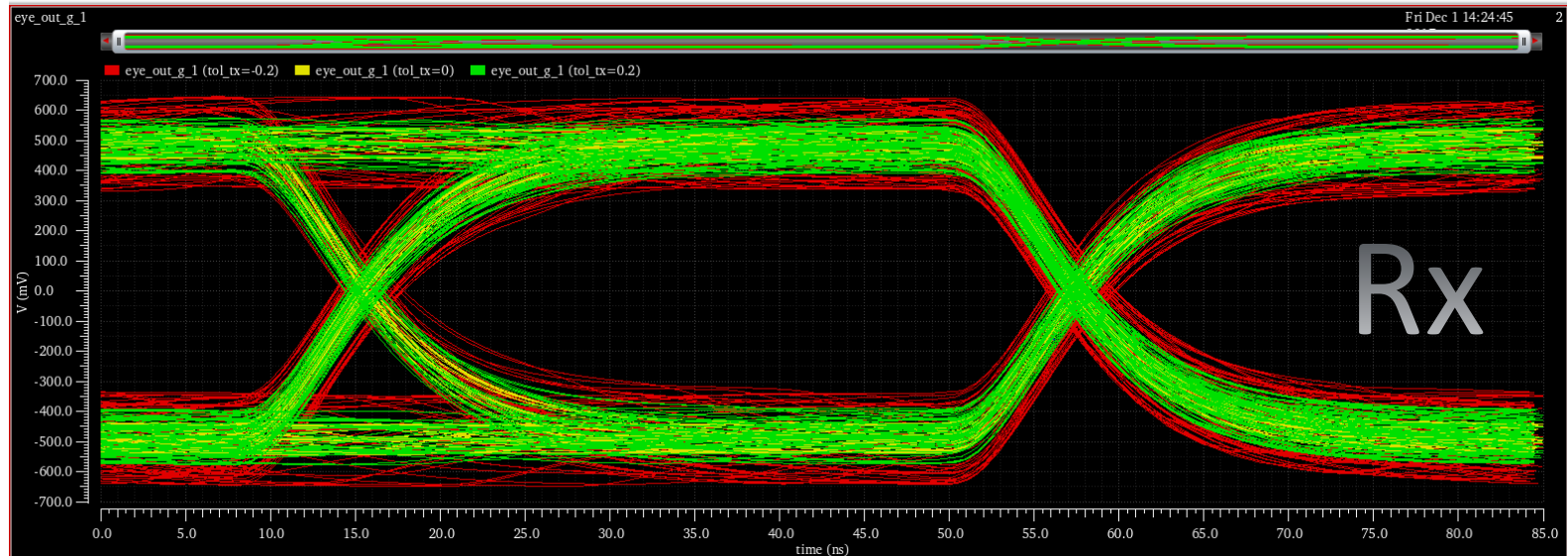
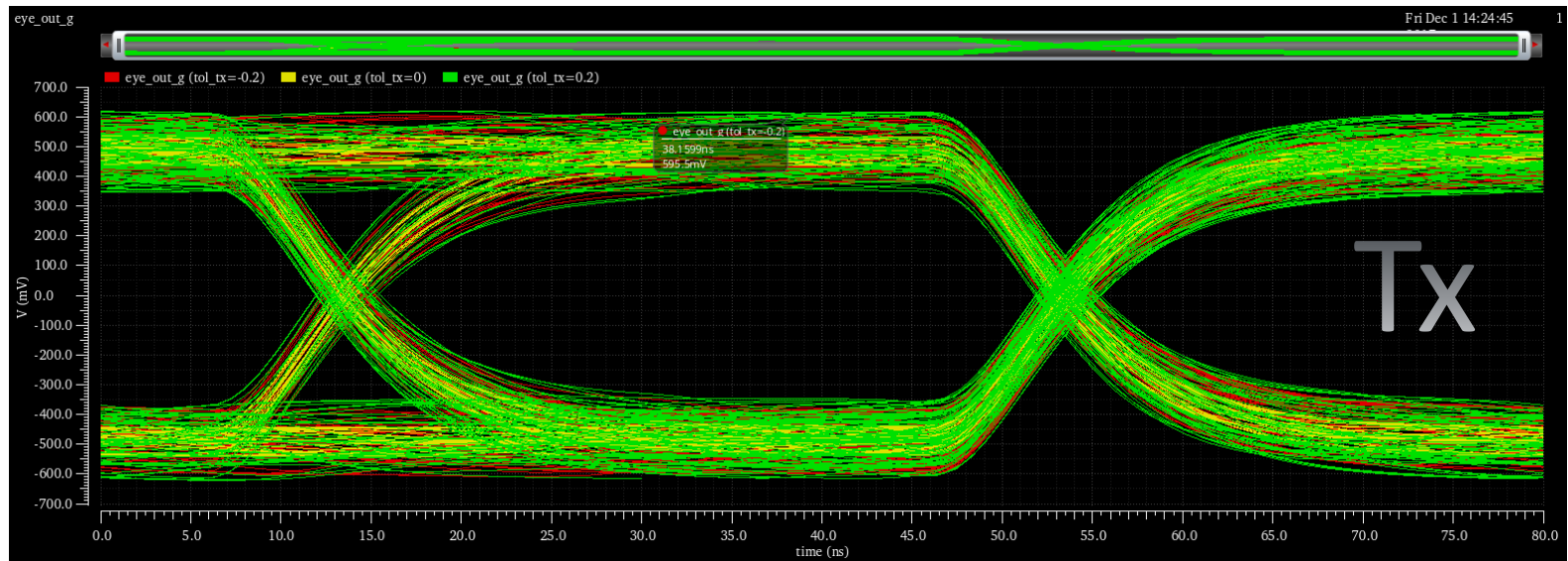

Microstrip, Point to Point

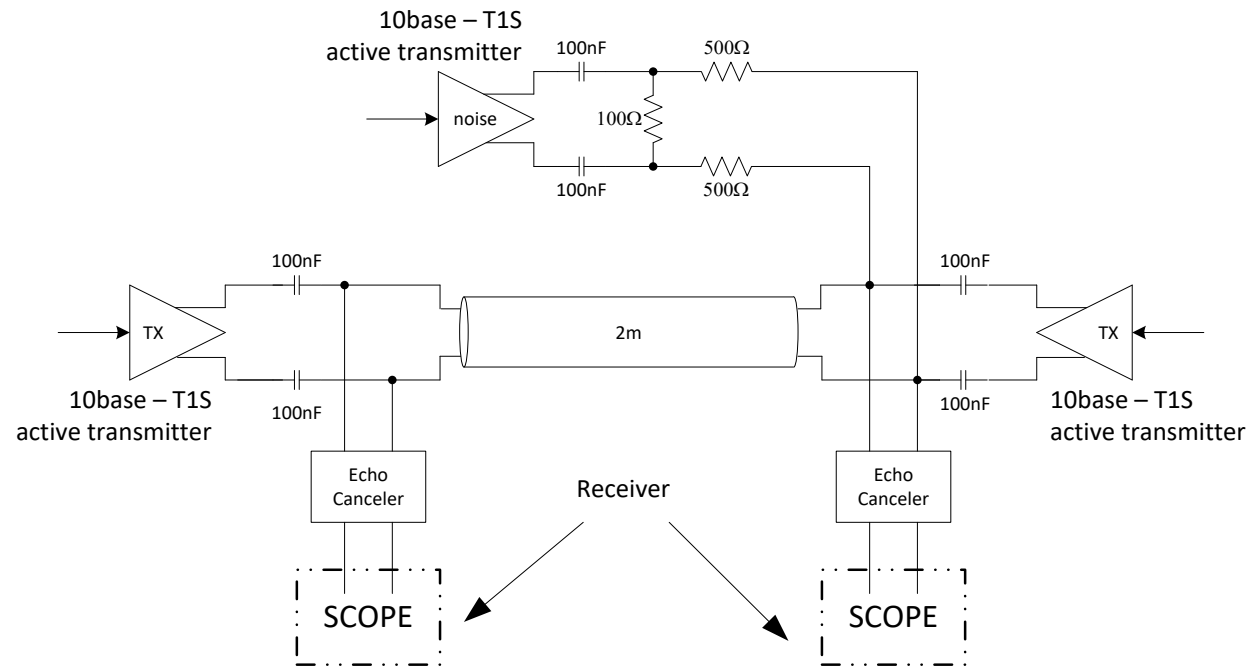

- 2 meter microstrip
- $100\Omega \pm 20\%$ transmitters
- Echo cancellation
- Alien Crosstalk Noise
 - T1S transmitter, $\sim 50\text{mVpp}$ when 1Vpp TX

Link segment Full Duplex with 50mVpp Alien Noise

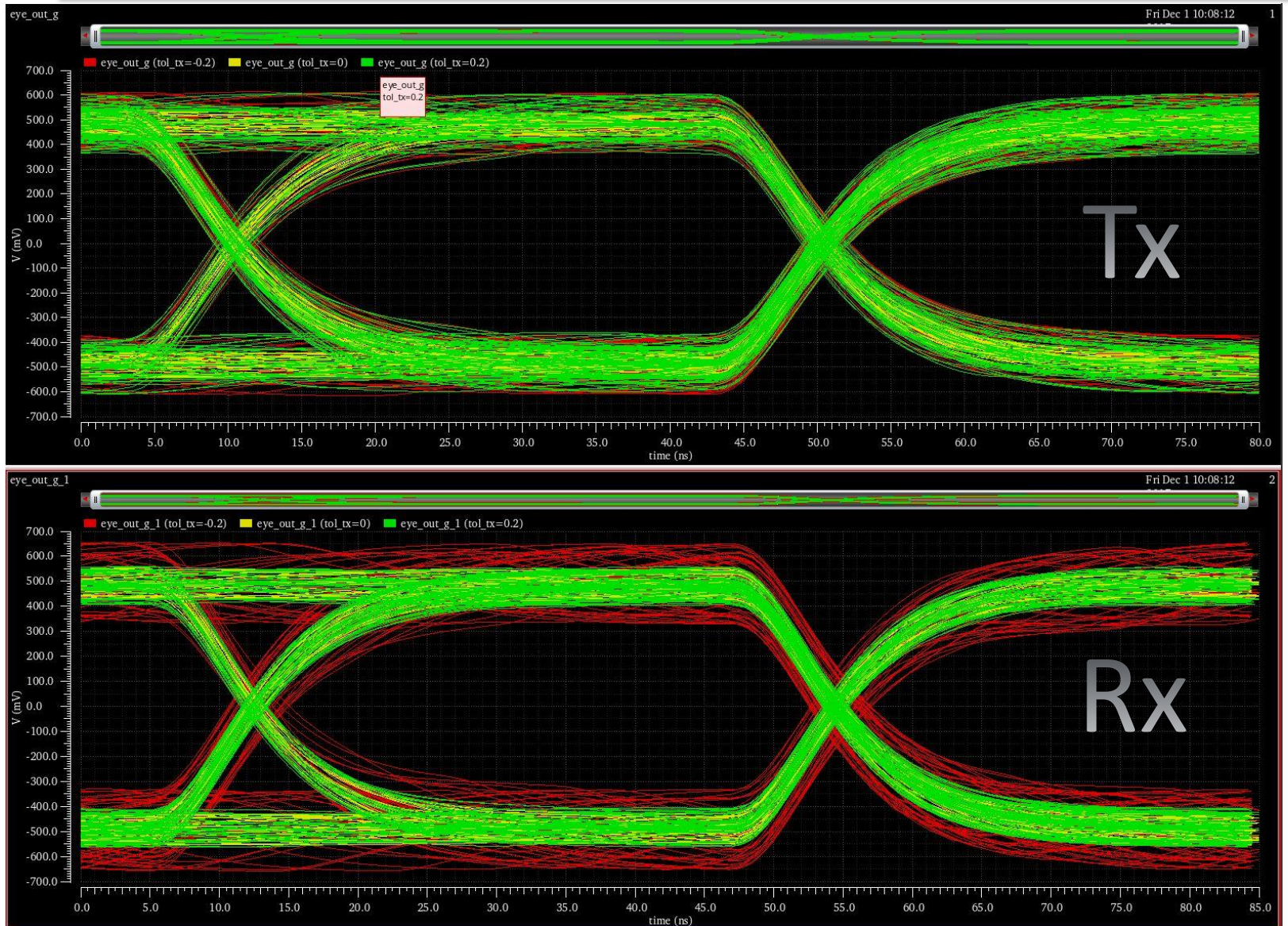

- **Current 10BASE-T1S specifications seems to be suitable for the backplane use case**
 - Both for Point-to-Point and Multidrop topology up to 32 nodes