



Architecting the Document

IEEE 802.3 HSSG

June 1999

David Law

3Com

David_Law@3Com.com



IEEE 802.3
Higher Speed
Study Group



Introduction

- First pass look at a 10G Document structure
 - Changes to existing Clauses
 - Additional new Clauses
- Assumption
 - Full Duplex only
 - No major modification to the MAC
- Expect this will evolve with the Study Group

Overview from 1000 Mb/s

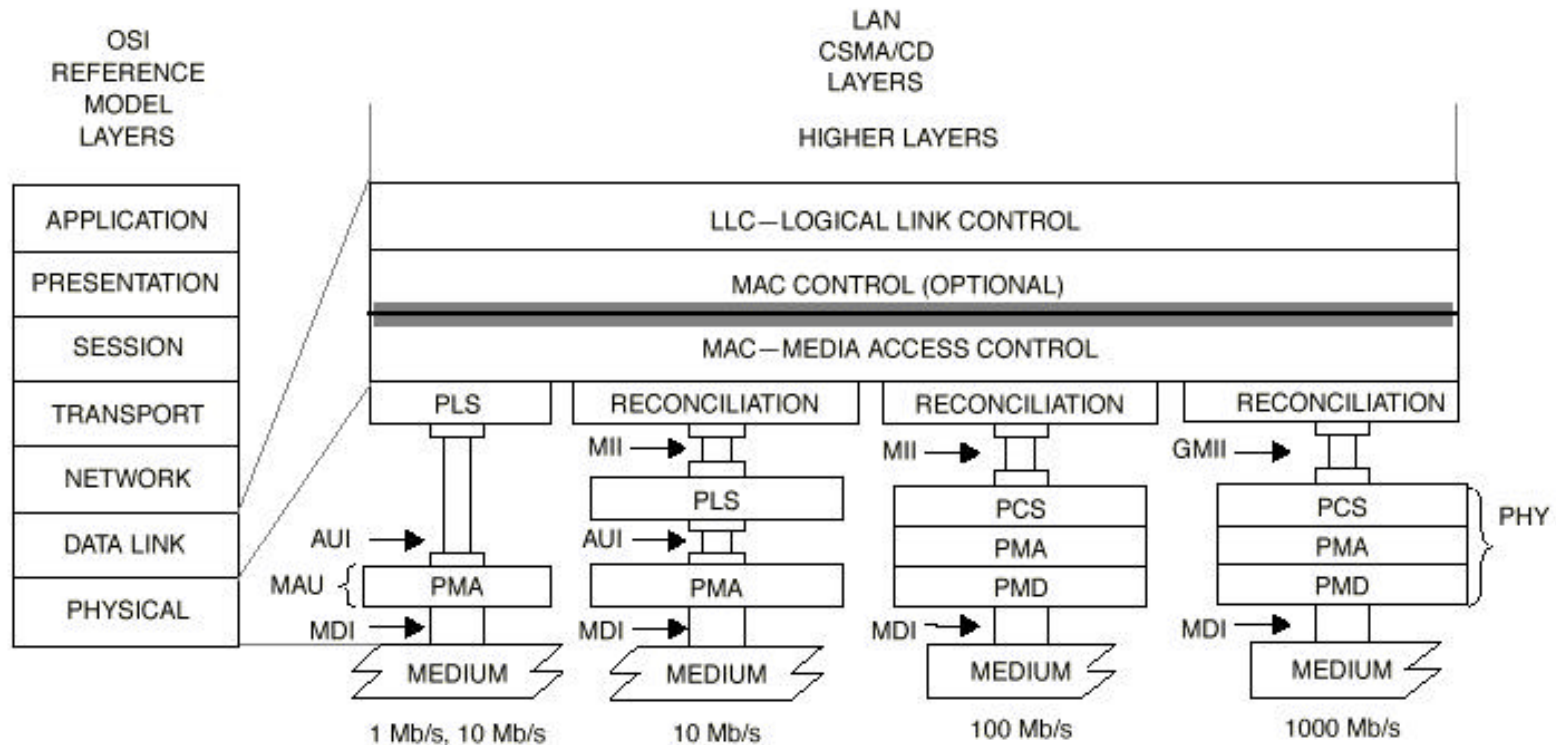

AUI = ATTACHMENT UNIT INTERFACE
 MDI = MEDIUM DEPENDENT INTERFACE
 MII = MEDIA INDEPENDENT INTERFACE
 GMII = GIGABIT MEDIA INDEPENDENT INTERFACE
 MAU = MEDIUM ATTACHMENT UNIT

PLS = PHYSICAL LAYER SIGNALING
 PCS = PHYSICAL CODING SUBLAYER
 PMA = PHYSICAL MEDIUM ATTACHMENT
 PHY = PHYSICAL LAYER DEVICE
 PMD = PHYSICAL MEDIUM DEPENDENT

**IEEE 802.3
 Higher Speed
 Study Group**

Existing Clauses

- Clause 1 - Introduction
- Clause 4 - Media Access Control
 - Minor changes such as Parameterized table
- Clause 22 - Reconciliation Sublayer (RS) and Media Independent Interface (MII)
 - On the basis that MII management interface will be used in 10G and that register set will therefore need extended

Existing Clauses (cont.)

- Clause 30, Annex 30A & 30B - Management
 - Minor changes as appropriate
 - Most in the PHY area - new PHY attributes
 - Counter sizes already fixed
- Annex 31B - MAC Control PAUSE operation
 - May need response time modification
- Clause 37 - 1000BASE-X Auto-Negotiation
 - Modification may be required if 1G/10G Auto-Negotiation on Fibre is to be supported

Overview from 1000 Mb/s

1000BASE-X

1000BASE-T

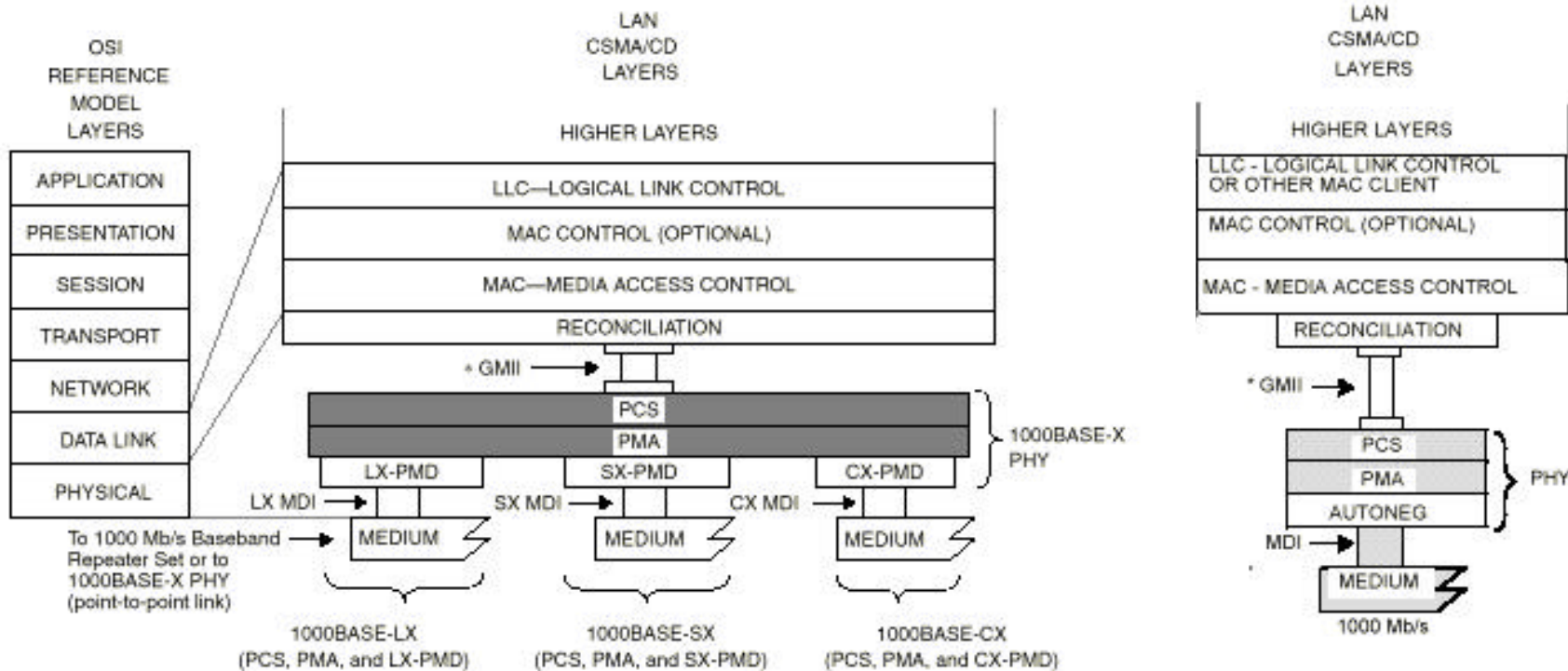

MDI—MEDIUM DEPENDENT INTERFACE

GMII—GIGABIT MEDIA INDEPENDENT INTERFACE

PCS—PHYSICAL CODING SUBLAYER

PMA—PHYSICAL MEDIUM ATTACHMENT

PHY—PHYSICAL LAYER DEVICE

PMD—PHYSICAL MEDIUM DEPENDENT

LX-PMD—PMD FOR FIBER—LONG WAVELENGTH, Clause 38

SX-PMD—PMD FOR FIBER—SHORT WAVELENGTH, Clause 38

CX-PMD—PMD FOR 150 Ω BALANCED COPPER CABLING, Clause 39

**IEEE 802.3
Higher Speed
Study Group**

Possible New Clauses

- Clause 43 - Introduction to 10,000 Mb/s baseband network
- Clause 44 - Reconciliation sublayer and '10G-MII'
- Clauses 45 to XX - PCS, PMA and PMD specifications as required

Summary

- Minor changes
 - 1, 4 (also 2, 3, 6 and elsewhere for Layer diagram)
- Substantive changes
 - 22 MII registers, 30 Management, 31B Pause, 37 Auto-Negotiation
- New Clauses
 - 43 Introduction, 44 Reconciliation, 45 to XX PCS, PMA and PMD as required