



Welcome

to the

Nov 8-11, 1999

MEETING OF THE 802.3 HIGH SPEED
STUDY GROUP (a.k.a. 10GbE)

Kauai, Hawaii

Jonathan Thatcher
jonathan@picolight.com

Agenda

- **Welcome and Introductions**
- **Select Recording Secretary**
- **Review / Approve Agenda**
- **Document Distribution**
- **E-mail Reflector, Web Site, and Miscellaneous Information**
- **Objectives for This Week**
- **Call for Patents**
- **Presentations**
- **Old Business**
- **New Business**
- **Planing for Jan Meeting**
- **Approve Minutes of York Meeting**
- **Review New Action Items**
- **Adjourn**

E-mail Reflector

- The IEEE has set up a reflector for this study group:
stds-802-3-hssg@mail.ieee.org
- The reflector can be used for announcements, comments, discussions, or dissemination of information related to the work of this study group
- The reflector should not be used for recruiting, advertising, soliciting, flaming, whining, subscribing, or unsubscribing
- To be added to the reflector, send an E- mail containing the following line:
[subscribe stds-802-3-hssg <your email address>](#)
to
[majordomo@ mail.ieee.org](mailto:majordomo@mail.ieee.org)
- To send a message to the HSSG reflector use the email address:
stds-802-3-hssg@ieee.org
- Subscriptions are on an individual basis only
- No proxy requests or reflectors will be subscribed

IEEE Web Site

- **Typical Plenary Meeting Plan (HSSG will meet during “Task Force” slots):**

<http://grouper.ieee.org/groups/802/3/plenary.html>

- **802.3ae 5 Criteria:**

http://grouper.ieee.org/groups/802/3/10G_study/public/criteria.pdf

- **802.3z PAR:**

http://grouper.ieee.org/groups/802/3/10G_study/public/PAR.pdf

- **802.3 Voting Rules**

<http://grouper.ieee.org/groups/802/3/rules/member.html>

- **802.3 Patent Policy**

<http://grouper.ieee.org/groups/802/3/patent.html>

IEEE 802.3 Requirements for Working Group Voting Membership

- **If you wish to vote on 802.3 standards at the Working Group Ballot stage you need to become a Voting Member of Working Group 802.3.**
- **Membership is by individual, not company.**
- **To become a voter:**
 - Attend and sign the attendance book at least 75% of the sessions of two Working Group 802.3 Plenary meetings (within the last four).
 - Full attendance at a two day or more duly constituted Working Group 802.3 Interim Meeting can be substituted for attendance at one plenary.
 - Have complete and current contact information recorded in the Working Group 802.3 database.
 - Request to become a voter during a Working Group 802.3 Opening or Closing plenary meeting when additions to the voter list are solicited by the
 - Chair from the "Potential Voter" list.
- **To remain a voter you must:**
 - Maintain current contact information in the Working Group 802.3 database.
 - Have 75% attendance during at least two of the last four plenaries (Attendance at an interim can substitute for attendance at no more than 1 plenary).
 - Participate in Working Group ballots. You can be dropped for not returning or abstaining in two of the last three ballots.

The Attendance Books

- **SIGN “THE BOOK” EVERY DAY**
- **KEEP IT MOVING**
- **IF YOU ARE NEW, SIGN THE NEW-BEES BOOK**
 - Put business card in back or fill out address...
 - Sign this book every day; no forward signing
- **DO NOT REMOVE THE BOOK FROM THE ROOM;
DO NOT COPY THE BOOK**

Future Meetings

- Jan 18-20; Dallas Texas
- March 6-10; Albuquerque, NM
- May TBD
- July 10-14; La Jolla, CA
- Other plenary meetings can be found in:

<http://grouper.ieee.org/groups/802/minutes/mar1999/meetschd.pdf>

- No other interim mtg's planned; Request for hosts:
 - If you would like to host a meeting for 2000: May, Sept, 2001: Jan, May, Sept,
 - Get authorization from your company and volunteer at November

Objectives for This Week

Priority One:

- Tutorial
- Approve PAR and 5 Criteria
- Submit draft to SEC

Priority Two:

- Begin to Consolidate Concepts
- Plan for Interim Meeting in JAN

HSSG Objectives (1 of 2)

- **Preserve the 802.3/Ethernet frame format at the MAC Client service interface.**
- **Meet 802 Functional Requirements, with the possible exception of Hamming Distance.**
- **Preserve minimum and maximum FrameSize of current 802.3 Std.**
- **Support full-duplex operation only.**
- **Support star-wired local area networks using point-to-point links and structured cabling topologies.**
- **Specify an optional Media Independent Interface (MII).**
- **Support proposed standard P802.3ad (Link Aggregation)**
- **Support a speed of 10.000 Gb/s at the MAC/PLS service interface**

HSSG Objectives (2 of 2)

- **Define two families of PHYs**
 - A LAN PHY, operating at a data rate of 10.000 Gb/s
 - A WAN PHY, operating at a data rate compatible with the payload rate of OC-192c/SDH VC-4-64c
- **Define a mechanism to adapt the MAC/PLS data rate to the data rate of the WAN PHY**
- **Provide Physical Layer specifications which support link distances of:**
 - At least 100 m over installed MMF
 - At least 300 m over MMF
 - At least 2 km over SMF
 - At least 10 km over SMF
 - At least 40 km over SMF
- **Support fiber media selected from the second edition of ISO/IEC 11801 (802.3 to work with SC25/WG3 to develop appropriate specifications for any new fiber media).**

Long Term Schedule

You are here

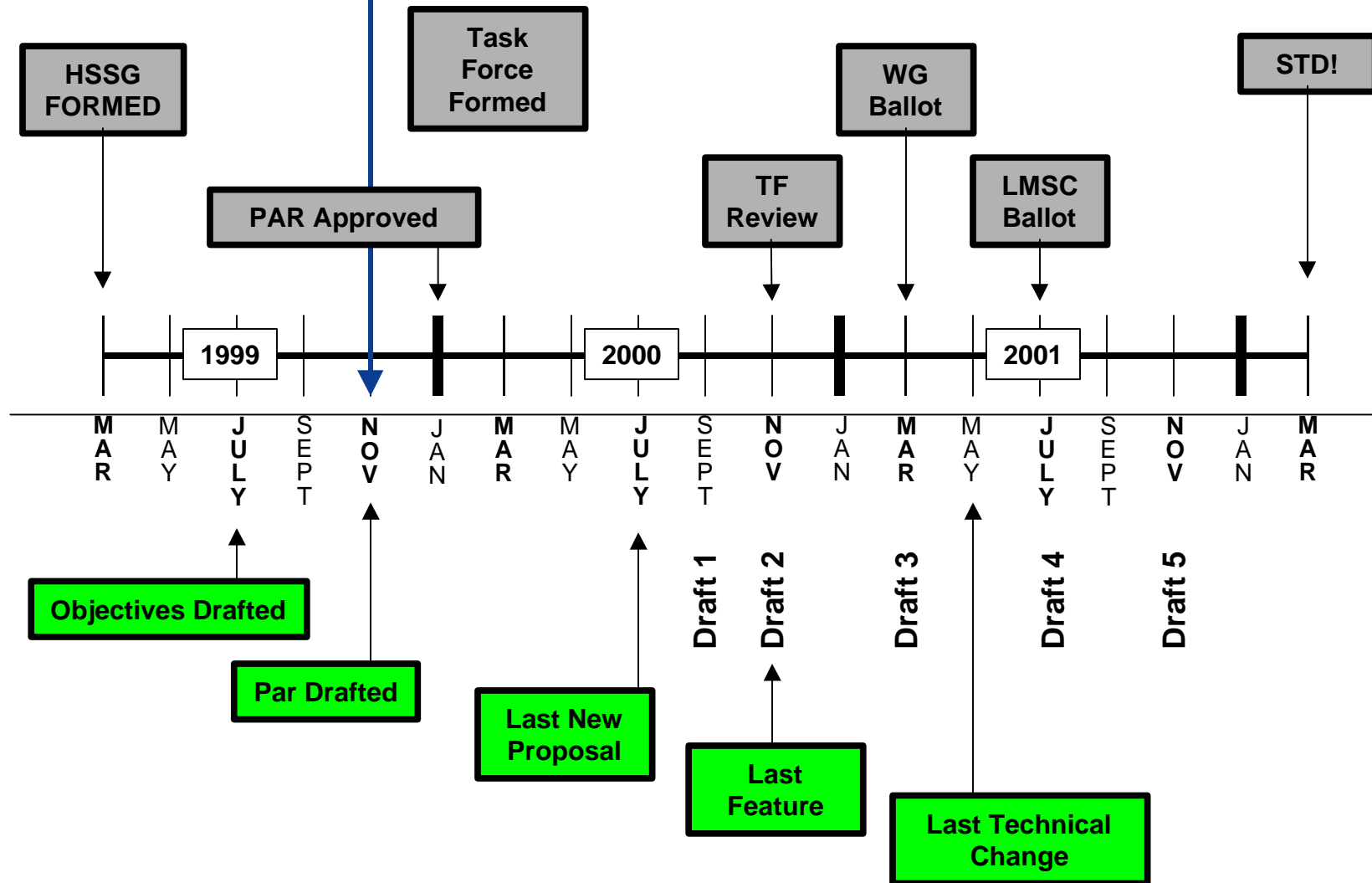

IEEE 802.3

High Speed Study Group

Short Term Schedule

- This week
 - Execute PAR approval process
 - 802.3 Approve PAR for forwarding to 802 SEC
 - SEC approve and forward to NesCom
- Jan, 2000
 - NesCom: Approve PAR
 - Interim Meeting: Jan 18-20; Dallas Texas
- 802.3 Plenary Meeting on March, 2000
 - First official meeting of task force

Business

■ OLD

- Review of Howard Frazier Recommendation on Presentation Material (move to 802.3)
- Geoff Thompson: report on ITU letter

■ NEW

- Motions

Motion 1

- Approve word changes to PAR
- Request 802.3 forward to SEC and NesCom
 - Moved: Tom Dineen
 - Seconded: Edward Chang
 - Technical: 75% required
 - Yes: 137
 - No: 0
 - Abstain: 0

Closing Discussions

- **PAR; 5 Criteria; Objectives will be published on HSSG web site**
- **Thank you to Presenters for Getting Advance Presentations on the Web**
- **Thank you to Presenters for Getting Requests for Time in Advance of the Meeting**
- **Use of Reflector (are we ringing here?)**
- **Planning for Jan Meeting**
- **Approve Minutes of York Meeting**
- **Review New Action Items**
- **Adjourn**