

802 Report from HSSG

IEEE 802 Plenary

Kauai, Hawaii

November 11, 1999

Jonathan Thatcher



HSSG Project Approval Request

Key Elements (1 of 3)

TITLE

Information Technology - Local & Metropolitan Area Networks - Part 3: Carrier Sense Multiple Access with Collision Detection (CSMA/CD) Access Method and Physical Layer Specifications - Media Access Control Parameters, Physical Layers and Management Parameters for 10 Gb/s Operation

Note: This Project is a supplement to an existing standard (not a new standard; not an update to an existing PAR)

HSSG Project Approval Request

Key Elements (2 of 3)

- **Target completion date:** March 2002
- **Purpose:** to extend the 802.3 protocol to an operating speed of 10 Gb/s and to expand the Ethernet application space to include Wide Area Network links in order to provide a significant increase in bandwidth while maintaining maximum compatibility with the installed base of 802.3 interfaces, previous investment in research and development, and principles of network operation and management
- For code point, add to **coordination:** ITU SG15, Question 11

HSSG Project Approval Request

Key Elements (3 of 3)

- **Scope:** Define 802.3 Media Access Control (MAC) parameters and minimal augmentation of its operation, physical layer characteristics and management parameters for transfer of LLC and Ethernet format frames at 10 Gb/s using full duplex operation as defined in the 802.3 standard. In addition to the traditional LAN space, add parameters and mechanisms that enable deployment of Ethernet over the Wide Area Network operating at a data rate compatible with OC-192c and SDH VC-4-64c payload rate.
- **Similar Projects:** There is no other project that uses the 802.3 MAC at speeds above 1000 Mb/s..

1. *Broad Market Potential*

Broad set(s) of applications

Multiple vendors, multiple users

Balanced cost, LAN Vs. attached stations

- Rapid growth of network and internet traffic has placed high demand on the existing infrastructure motivating the development of higher performance links. Quantitative presentations have been made to the 802.3 HSSG indicating significant market opportunity.
- 10 Gb/s 802.3 solution extends Ethernet capabilities providing higher bandwidth for multimedia, distributed processing, imaging, medical, CAD/ CAM, and pre-press applications by improving the performance of:

Passed by acclamation

- 140 participants attended the 10 Gigabit call-for-interest, representing at least 55 companies, indicate that they plan to participate in the standardization of 10 Gb/s 802.3. 139 Indicated that this is the right time to start. Attendance and interest has increased steadily since that time.
- This level of commitment indicates that a standard will be supported by a large group of vendors. This in turn will ensure that there will be a wide variety of equipment supporting a multitude of applications.
- Prior experience scaling 802.3 across the range of 1 to 1000 Mb/ s indicates that the cost balance between adapters, switches, and the infrastructure remains roughly constant. 10 Gb/s Ethernet should continue this trend.

2. Compatibility with IEEE Standard 802.3

Conformance with CSMA/ CD MAC, PLS

Conformance with 802.2

Conformance with 802 FR

- The proposed standard will conform to the full-duplex operating mode of the 802.3 MAC, appropriately adapted for 10 Gb/ s operation. Half-duplex (CSMA/CD) operation will not be supported at 10 Gb/s.
- As was the case in previous 802.3 standards, new physical layers

Passed by acclamation

- The proposed standard will conform to the 802.1 Architecture, Management and Interworking.
- The proposed standard will conform with the 802 Functional Requirements Document (with the possible exception of Hamming distance).
- The proposed standard will define a set of systems management objects which are compatible with OSI and SNMP system management standards.

3. Distinct Identity

Substantially different from other 802.3 specs/ solutions
Unique solution for problem (not two alternatives/ problem)
Easy for document reader to select relevant spec

- The proposed standard is an upgrade path for 802.3 users, based on the 802.3 MAC, running at 10 Gb/s.
- By adapting the existing 802.3 MAC protocol for use at 10 Gb/s, this proposed standard will maintain maximum compatibility with the installed base of over 600 million Ethernet nodes.
- The established benefits of the 802.3 MAC include:

Passed by acclamation

- The Management Information Base (MIB) for 10 Gb/s 802.3 will be extended in a manner consistent with the 802.3 MIB for 10 / 100 / 1000 Mb/s operation. Therefore, network managers, installers, and administrators will see a consistent management model across all operating speeds.
- Two PHY families will address two distinct application spaces, the LAN and the WAN.
- The proposed standard will be a supplement to the existing 802.3 standard, formatted as a collection of new clauses, making it easy for the reader to select the relevant specification.

4. Technical Feasibility

Demonstrated feasibility; reports - - working models
Proven technology, reasonable testing
Confidence in reliability

- Technical presentations, given to 802.3, have demonstrated the feasibility of using the 802.3 in useful network topologies at a rate of 10 Gb/s.
- The principle of scaling the 802.3 MAC to higher speeds has been well established by previous work within 802.3. The 10 Gb/s work will build on this experience.

Passed by acclamation

between 10, 100, and 1000 Mb/s.

- Vendors of optical components and systems are building reliable products which operate at 10 Gb/s, and meet worldwide regulatory and operational requirements.
- Component vendors have presented research on the feasibility of physical layer signaling at a rate of 10 Gb/s on fiber optic media using a wide variety of innovative low cost technologies.
- 10 Gb/s Ethernet technology will be demonstrated during the course of the project, prior to the completion of the sponsor ballot.

5. Economic Feasibility

Cost factors known, reliable data
Reasonable cost for performance expected
Total Installation costs considered

- Cost factors are extrapolated from the OC-192 component supplier base and technology curves.
- A target cost increase of 3X of 1000BASE-X with a ten-fold increase in available bandwidth in the full duplex operating mode will result in an improvement in the cost-performance ratio by a

Passed by acclamation

- Customers will in some cases be able to re-use fiber that has been installed in accordance with ISO/IEC 11801, and in other existing fiber facilities.
- Installation costs for new fiber runs based on established standards are well known and reasonable.
- Network design, installation and maintenance costs are minimized by preserving network architecture, management, software, and structured cabling.

Motion 1

- Approve 802.3 HSSG PAR & 5 Criteria
- Request 802 Executive to Approve PAR and Forward to NesCom
 - Moved: Jonathan Thatcher in behalf of HSSG
 - Seconded: Thomas Mathey
- Technical: Yes
- Yes: **90**
- No: 0
- Abstain: 0

HSSG Objectives (1 of 2)

- **Preserve the 802.3/Ethernet frame format at the MAC Client service interface.**
- **Meet 802 Functional Requirements, with the possible exception of Hamming Distance.**
- **Preserve minimum and maximum FrameSize of current 802.3 Std.**
- **Support full-duplex operation only.**
- **Support star-wired local area networks using point-to-point links and structured cabling topologies.**
- **Specify an optional Media Independent Interface (MII).**
- **Support proposed standard P802.3ad (Link Aggregation)**
- **Support a speed of 10.000 Gb/s at the MAC/PLS service interface**

HSSG Objectives (2 of 2)

- **Define two families of PHYs**
 - A LAN PHY, operating at a data rate of 10.000 Gb/s
 - A WAN PHY, operating at a data rate compatible with the payload rate of OC-192c/SDH VC-4-64c
- **Define a mechanism to adapt the MAC/PLS data rate to the data rate of the WAN PHY**
- **Provide Physical Layer specifications which support link distances of:**
 - At least 100 m over installed MMF
 - At least 300 m over MMF
 - At least 2 km over SMF
 - At least 10 km over SMF
 - At least 40 km over SMF
- **Support fiber media selected from the second edition of ISO/IEC 11801 (802.3 to work with SC25/WG3 to develop appropriate specifications for any new fiber media).**

Long Term Schedule

You are here

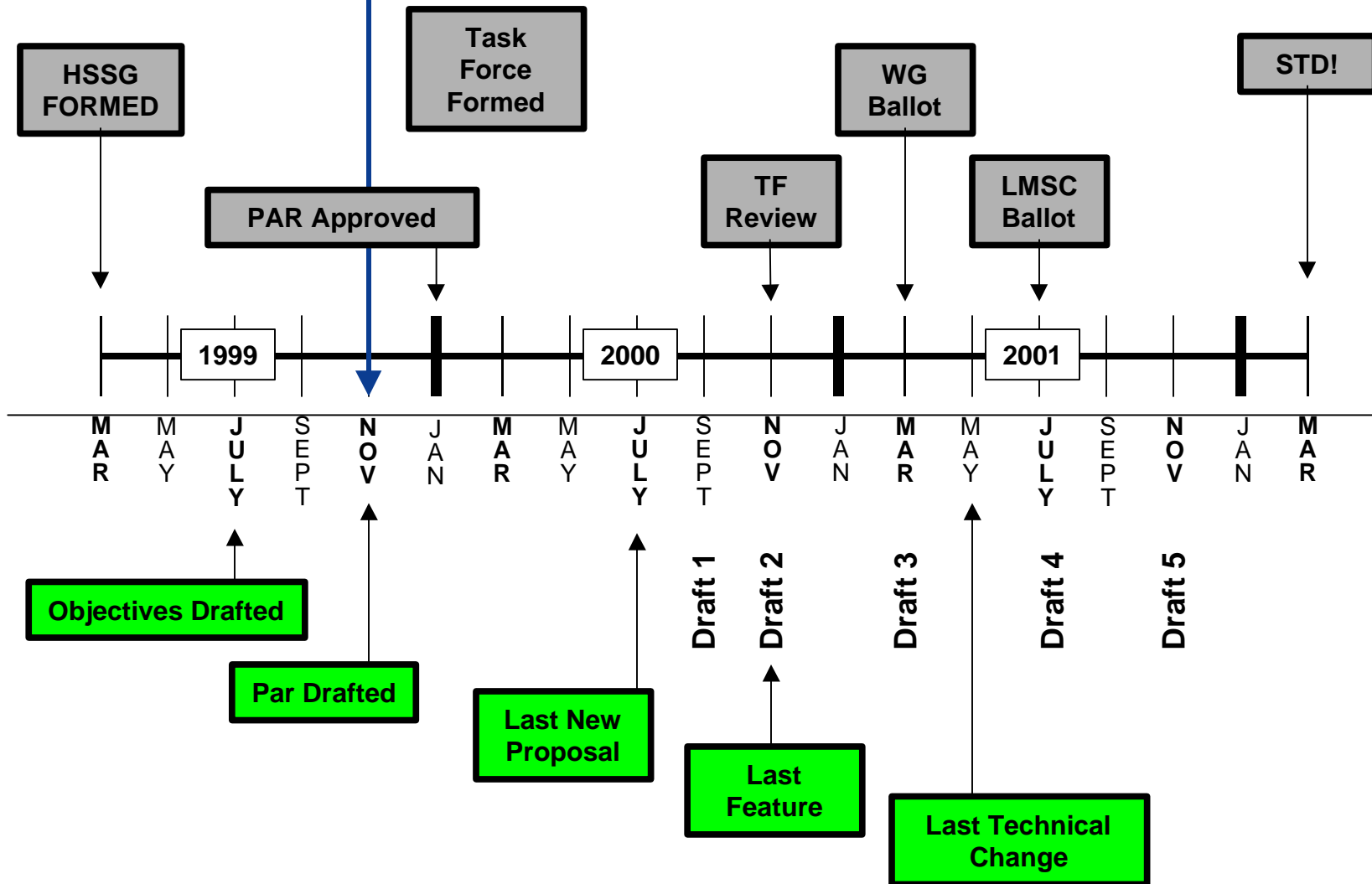

IEEE 802.3

High Speed Study Group