



Consideration on 25 Gb/s Ethernet single mode fiber PMDs

Li Cao, Accelink
Yi Jiang , Accelink
Di Zhang , Accelink
Wanhui He, Accelink
Wenyu Zhao , CAICT

Application scenarios

◆ 25GE in enterprise and campus networks:

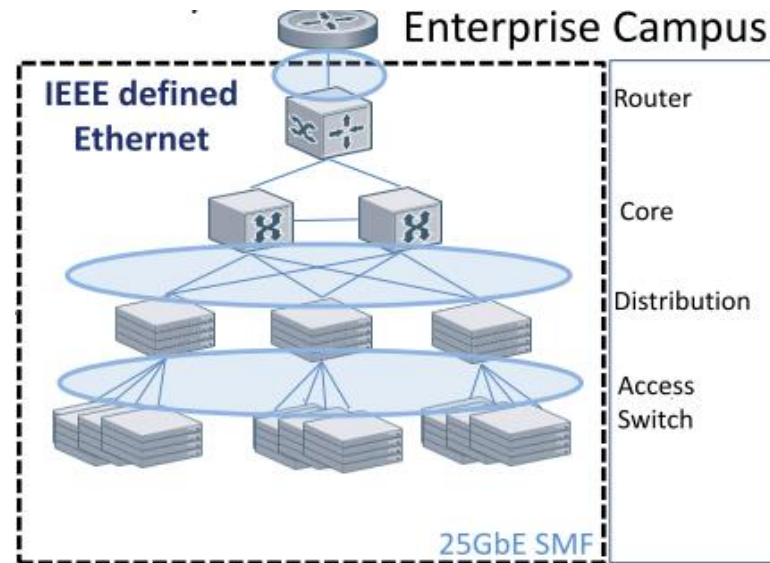

According to the opinions of the enterprise IT Department. 25GE ports have the chance to replace 10GE ports of switch and router in the future. But now for most enterprise the need is not very urgent.

Maybe in campus that video service is more popular and the bandwidth demand is more urgent in campus .

◆ 25GE in metro access network

- From a preliminary investigation of a telecom operator in China, in metro access area, Mobile backhaul network (from BBU to the switch in end offices) and OLT upward (from OLT to the switch in access offices) is mainly 10G now. With the increase of data rate of wireless and PON, 10G will be not enough. 25G is closely watched.

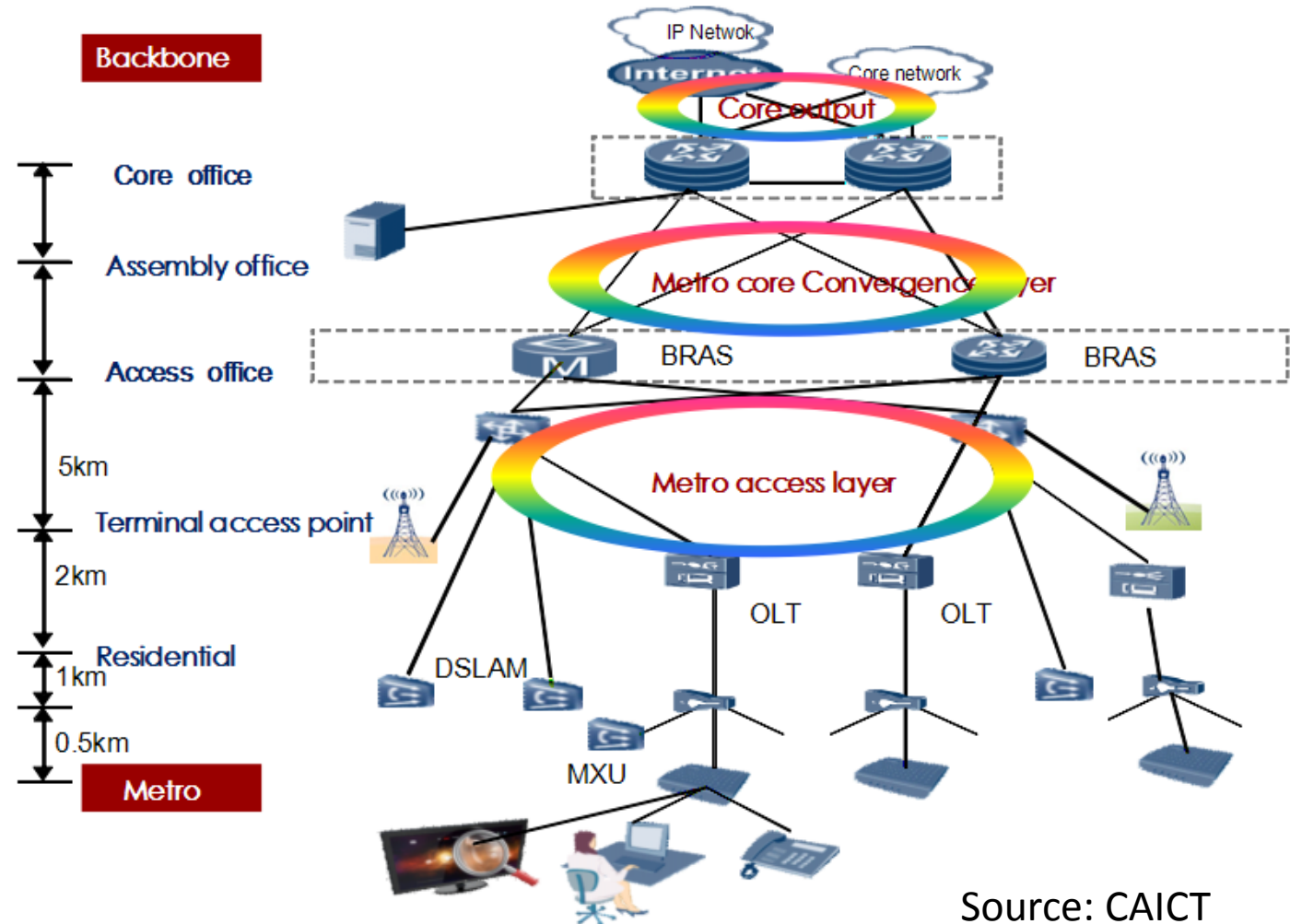

Source: CAICT

Distance

◆ The transmission distance of 25GE SMF PMDs

According to the existing Ethernet standard and 25G single mode PMDs' application scenarios, 25GBASE-R PMDs' transmission distance is likely to be 2km、10km、40km and 80km.

◆ 2Km ? 10km ? 40km ? 80Km

For 80~90% enterprise、campus and metro access scenarios, the distance is less than 40km. And more than 50% distance is less than 10km. So standard for 10Km and 40km is the most necessary.

Sometimes maybe 2Km is enough. But from the technical point of view, the technical schemes of 2Km and 10Km are almost the same. The cost of 2Km is about 10% lower than that of 10Km. It's not very large difference. So maybe we don't need to talk about 2Km PMDs individually.

Now the device index of laser and Pin or APD can't satisfy the power budget of 80Km. It's difficult to realize 80Km 25G single lane PMDs in SFP28 package.

Technology feasibility of 25Gb/s 10km SMF PMDs

◆ Scheme

25Gb/s bandwidth TOSA and ROSA have been used in 100GE CFP and QSFP modules.

Three schemes exist:

- EML+ PIN
- DML+ PIN
- SIP

◆ DML + PIN is the best choice.

	Cost	Power consumption	Maturity
EML+PIN	high	high	yes
DML+PIN	low	low	yes
SIP			no

And the other shortcoming of SIP is that the early investment of SIP technology is relatively large, maybe the volume of single lane 25G SMF PMDs is not that much. So it is not a good choice.

◆ Test results of DML+PIN scheme .

- the following diagram is DML transmitter eye diagram and PIN receiver sensitivity under 70°C we tested. The results under 25°C and -5°C are better than that of 70°C.

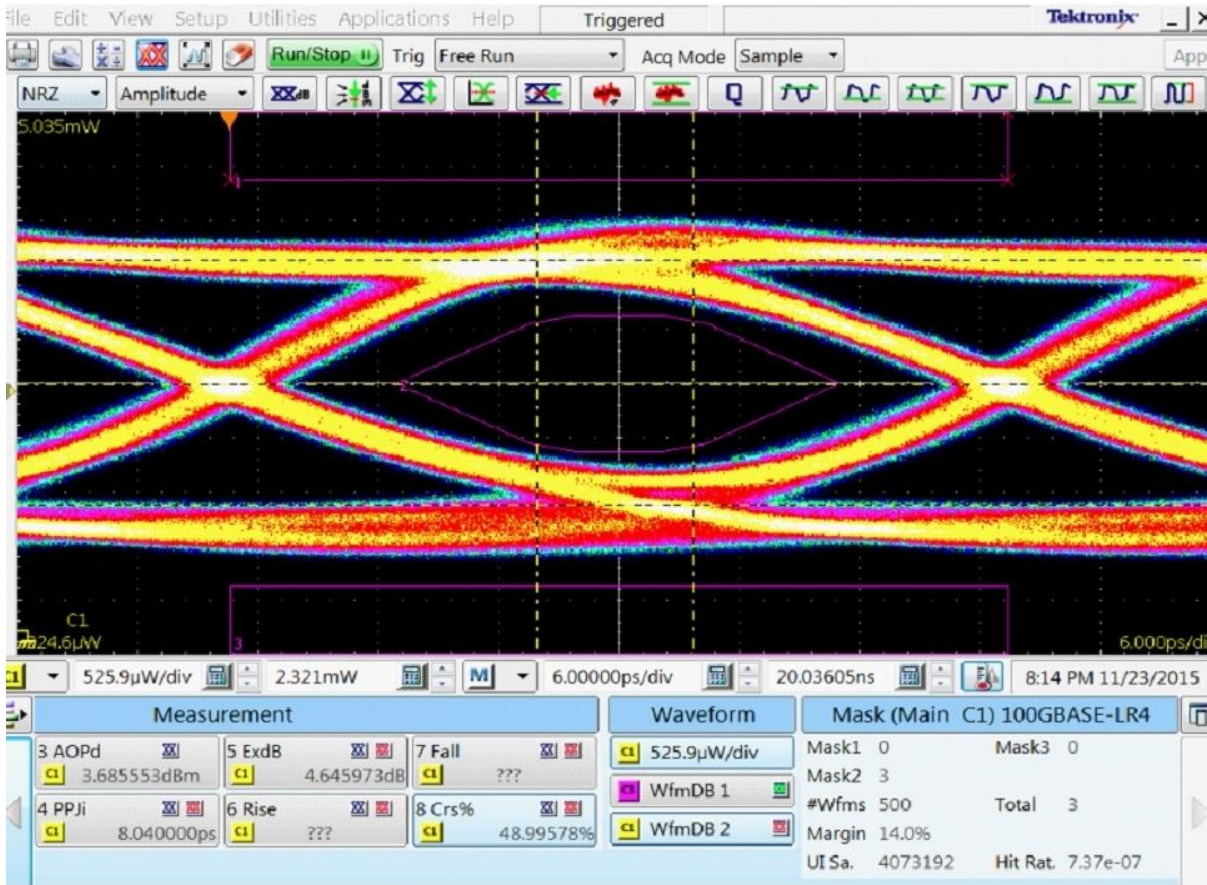

Mask margin>14% ER:4.64dB

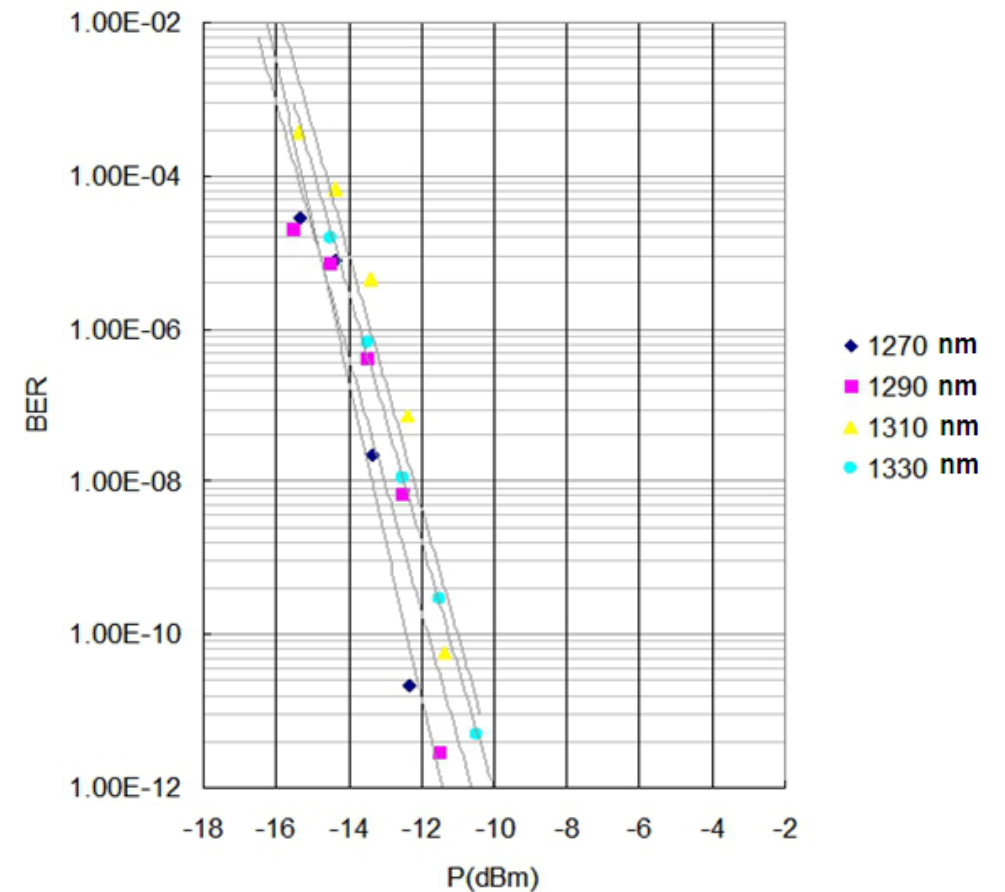

PIN Receiver sensitivity 70°C

◆ Critical component :

- ✓ DML is good for 10km operation
- ✓ TOSA compatible with SFP28 Transceiver
- ✓ ROSA compatible with SFP28 Transceiver

- So 25G BASE-L 10Km PMD is technically feasible.
- DML+PIN can be used to realize 25GBASE-L.

Technology feasibility of 25Gb/s 40km SMF PMDs

◆ Scheme

- The sensitivity of PIN is about -12dBm, For 20.5dB power budget of 40km ,it's not enough. So in 100GBASE-ER4 module,SOA is used .
- Problems come in single lane 25G SMF PMD scheme:
The price 、 size and power consumption of SOA is too high .
- So APD scheme will be the winner.

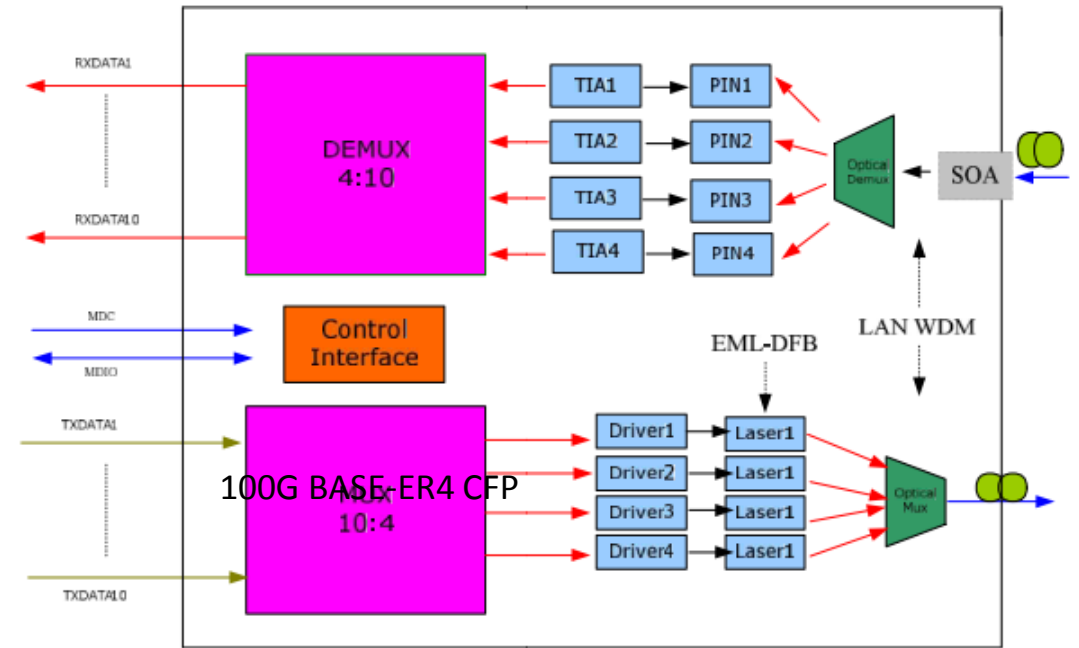

100GBASE-ER4

Potential of single lane 25Gb/s

- ◆ The vigorous development of 100G will speed up the cost reduction of the 25G industry chain.

•The right chart is the deployment of 100Gb/s line side interfaces of China from 2013 to 2015 . The client side is mostly single mode 100GE interface .From this we can see 100GE single mode ports' number is growing very quickly .It's very useful for reducing the cost of the 25G industry chain.

100G ports unit: k

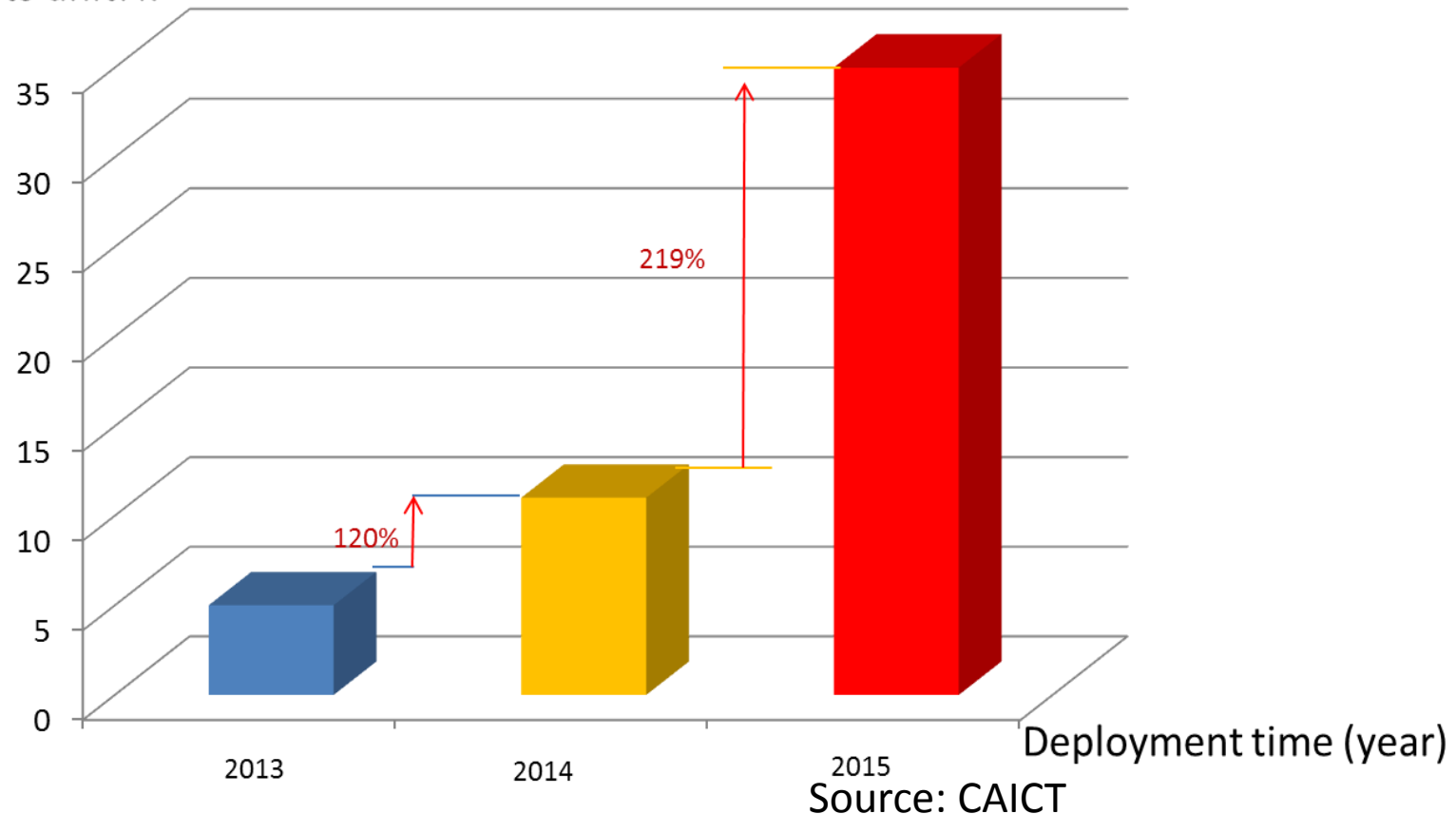

Summary

◆ For the reason of the application scenarios and technical feasibility, 10km and 40km standards are the most necessary.

Thank you!