

# PSE PI Imbalance

**Ken Bennett – Sifos Technologies, Inc.**  
**Resistive Imbalance Ad Hoc**  
**June 24, 2014**

# Content

- Review of inequality between **PSE PI P2PRunb** and its Contribution to **End-to-End P2PRunb**
- A mathematically derived PSE PI Specification using worst case **End-to-End P2PRunb**
- A Possible Test Method
- Comments
- Annex

# A fixed PSE PI Runbalance spec *can't* be derived from worst case P2P Runb

- The following is a Resistive imbalance equation for determining current imbalance between pairs (Single source, single PD)

$$\frac{\sum R_{max} - \sum R_{min}}{\sum(R_{max} + R_{min})}$$

- This can be separated into contributions of the PSE, PD and Channel:

$$\frac{R_{pseRmax} - R_{pseRmin}}{\sum(R_{max} + R_{min})} + \frac{R_{CableRmax} - R_{CableRmin}}{\sum(R_{max} + R_{min})} + \frac{R_{pdRmax} - R_{pdRmin}}{\sum(R_{max} + R_{min})}$$

- PSE PI Runbalance contribution is not the same as PSE PI Runbalance

$$\frac{R_{pseRmax} - R_{pseRmin}}{\sum(R_{max} + R_{min})} \neq \frac{R_{pseRmax} - R_{pseRmin}}{R_{pseRmax} + R_{pseRmin}}$$

- Changes in total resistance can change Runbalance requirements.
- An Runbalance specification at the PSE PI does not take this into account*

## A PSE Resistance Limit *can* be derived from End-to-End P2PRunb....

- Annex A shows the derivation of the following from the **End-to-End P2PRunb** Equation

$$R_{psemax} = X * R_{psemin} + Y$$

$$X = \frac{1 + R_{unb}}{1 - R_{unb}}$$

$$Y = \frac{1 + R_{unb}}{1 - R_{unb}} [R_{chmin} + R_{pdmin}] - [R_{chmax} + R_{pdmax}]$$

**$R_{unb}$**  = Worst case **End-to-End P2PRunb**

**$R_{chmax}$ ,  $R_{chmin}$**  = Channel Resistance values for Worst case **End-to-End P2PRunb**

**$R_{pdmax}$ ,  $R_{pdmin}$**  = PD Effective Resistance values for Worst case **End-to-End P2PRunb**

- X, Y can be reduced to constants, based upon the worst case modeling
- Result can be used to determine Resistance limits between PI pairs of the same polarity

# A Possible Test Method

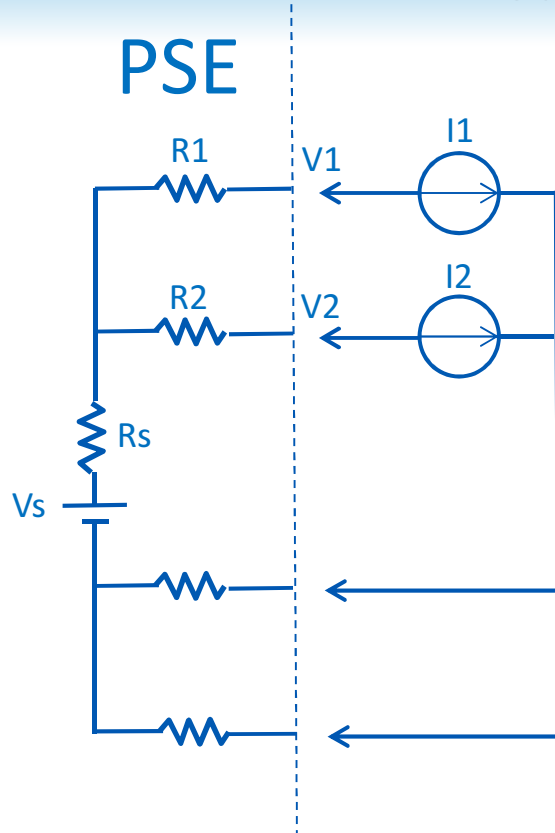

PSE

## Steps:

1. I1 = I<sub>max</sub>, I2 = I<sub>min</sub>, Measure V1, V2
2. Calculate R1: = (V2-V1)/I1
3. I1 = I<sub>min</sub>, I2 = I<sub>max</sub>, Measure V1, V2
4. Calculate R2: = (V1-V2)/I2
5. Calculate Runb: (R<sub>max</sub>-R<sub>min</sub>)/(R<sub>max</sub>+R<sub>min</sub>)
6. I1, I2 = I<sub>max</sub>, Measure V1, V2
7. Calculate Vunb: (V<sub>max</sub>-V<sub>min</sub>)/(V<sub>max</sub>+V<sub>min</sub>)

## Requirements for Compliance:

$$R_{max} \leq X \cdot R_{min} + Y \quad (\text{See previous Slide for X, Y})$$

$$V_{unb} \leq R_{unb} + N$$

(V<sub>unb</sub> due to R<sub>unb</sub> is expected...

N is an additional TBD allowance)

## Parameter Descriptions:

I<sub>min</sub>: 0mA (Up to 10mA if needed for MPS)

I<sub>max</sub>: At least 90% of Maximum Port Capability  
(Variant tests could use Resistive Loading)

Test shown is for positive pairs.  
Negative pair tests would repeat on negative pairs with circuit to right



# Comments

- Applicable to PSE's which
  - Are Type 3, 4
  - Don't otherwise provide a balancing technique
- Other suggested requirements for applicable PSE's
  - 4 pair powering shall be sourced from a single DC supply
  - If used, a forward-biased protection diode shall be installed in a path common to both pairs of the same polarity
  - Could tighten the overall End-to-End P2PRunb by specifying a lower Limit on Rpsemin
    - Helps the PD imbalance, which may not have a practical test
    - Rpsemin in the AD Hoc model is an extreme case that can be addressed with a couple of inexpensive resistors

# Annex

# Derivation of PSE Resistance Limit

Let  $R_\alpha = R_{chmax} + R_{pdmax}$ ,  $R_\beta = R_{chmin} + R_{pdmin}$  :

$$\frac{R_{psemax} - R_{psemin} + R_\alpha - R_\beta}{R_{psemax} + R_{psemin} + R_\alpha + R_\beta} = R_{unb} \quad \leftarrow \text{P2PRunb Equation}$$

$$R_{psemax} - R_{psemin} + R_\alpha - R_\beta = R_{unb} [R_\alpha + R_\beta] + R_{unb} [R_{psemax} + R_{psemin}]$$

$$R_{psemax} - R_{psemin} - R_{unb} [R_{psemax} + R_{psemin}] = R_{unb} [R_\alpha + R_\beta] - [R_\alpha - R_\beta]$$

$$[1 - R_{unb}]R_{psemax} - [1 + R_{unb}]R_{psemin} = R_{unb} [R_\alpha + R_\beta] - [R_\alpha - R_\beta]$$

$$[1 - R_{unb}]R_{psemax} = [1 + R_{unb}]R_{psemin} + R_{unb} [R_\alpha + R_\beta] - [R_\alpha - R_\beta]$$

$$R_{psemax} = \frac{1 + R_{unb}}{1 - R_{unb}} R_{psemin} + \frac{R_{unb} [R_\alpha + R_\beta] - [R_\alpha - R_\beta]}{1 - R_{unb}}$$

$$R_{psemax} = \frac{1 + R_{unb}}{1 - R_{unb}} R_{psemin} + \frac{1 + R_{unb}}{1 - R_{unb}} R_\beta - R_\alpha$$



# Runbalance Example *(Values are not from the model)*

- **Simulation Conditions common to each:**
  - ~1M Cable, worst case model used to arrive at ~26%
  - PD with Diode Bridge
  - PD, Channel fixed, PSE varied

	PSE Runbal		Channel		PD Runbal	
Rpse other	0.001	0.001				
Rtrans	0.06	0.065				
Rconn	0.015	0.03	0.015	0.03		
Wire			0.0275	0.0285		
Rconn			0.015	0.03	0.015	0.03
Rtrans					0.06	0.065
Rdiode					0.8557	1.537
Unbalance	0.1163	12%	0.2123	21%	0.2737	27%
<b>System Runbalance</b>						
	0.26115	26.1%				
<b>Simulation lunbalance Result</b>						
(mA)	658.35	385.65	0.261207	26.1%		

	PSE Runbal		Channel		PD Runbal	
Rpse other	0.23	0.392				
Rtrans	0.06	0.065				
Rconn	0.015	0.03	0.015	0.03		
Wire			0.0275	0.0285		
Rconn			0.015	0.03	0.015	0.03
Rtrans					0.06	0.065
Rdiode					0.8557	1.537
Unbalance	0.2298	23%	0.2123	21%	0.2737	27%
<b>System Runbalance</b>						
	0.26118	26.1%				
<b>Simulation lunbalance Result</b>						
(mA)	658.35	385.65	0.261207	26.1%		

**PSE Runbalance can vary significantly for a fixed total Runbalance**  
**Reason:  $PI\ Runbalance \neq PI\ Runbalance\ Contribution\ to\ P2P\ Runb$**