



“Channel” vs “Link section” effects on pair-to-pair resistance unbalance requirements

September 2017

Yair Darshan

Rev001a

ydarshan@microsemi.com

Terms used in this presentation.

- Runb is used for the End to End pair-to-pair effective resistance unbalances.
- Rcon is the connector resistance. Rcon consist of the plug resistance when it is in contact with the jack resistance.
- Other unbalance terms are used as per their definitions in D3.0

Objectives

- To investigate the effect of changing from “channel” definition used until D2.4 to “link section” used in D2.5 and up, on:
 - PSE PI
 - PD PI
 - The “channel”
 - The “link section”
 - Icon-2P_unb and Equation 145-15.
 - Ipeak-2P_unb
 - ILIM-2P

Background – D2.4 vs D3.0, Long Cable model.

■ In D2.4

- PSE PI – equipment connector (the plug + jack) was part of the PSE PI.
- PD PI – equipment connector (the plug + jack) was part of the PD PI.
- “Channel” – consist of up to 4 connectors and 100m cordage and cable.
- Resulting with total 6 connector model from end to end.

■ In D3.0

- Link section – Includes the “Channel” connectors + the plugs going to the equipment with 100m cordage and cable. The Equipment include the Jack only.
- The question is: does it changes pair-to-pair unbalance requirements?

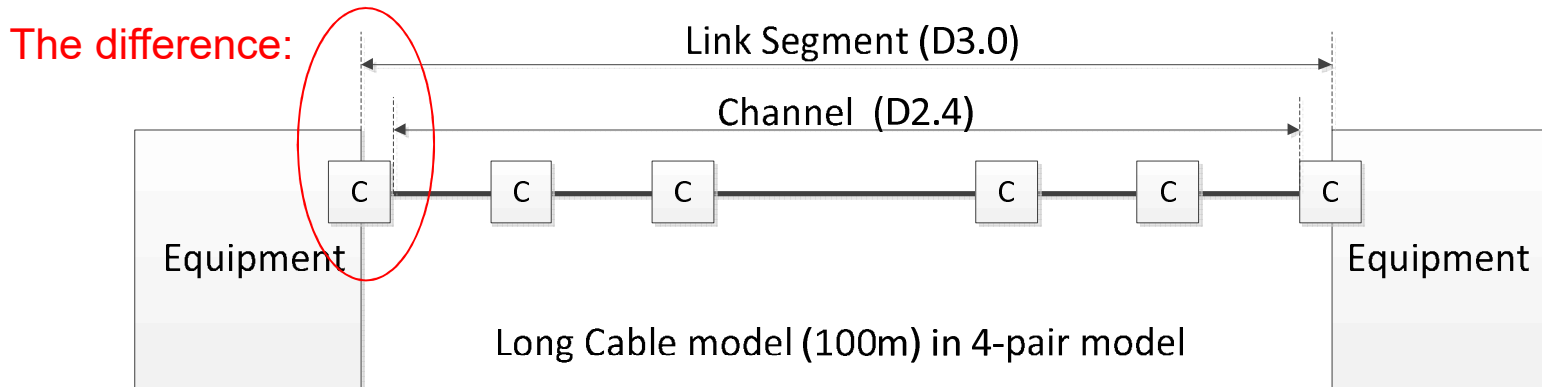

Background – D2.4 vs D3.0, Short Cable model.

- **In D2.4**
 - PSE PI – equipment connector (the plug + jack) was part of the PSE PI.
 - PD PI – equipment connector (the plug + jack) was part of the PD PI.
 - “Channel” – consist of 0 connectors and 2.65m cordage.
 - Resulting with total 2 connector model from end to end.
- **In D3.0**
 - Link section – Include the plugs of the short “Channel” cable.
 - The PSE PI and PD PI include only the jacks.
- **The question is: does it changes pair-to-pair unbalance requirements?**

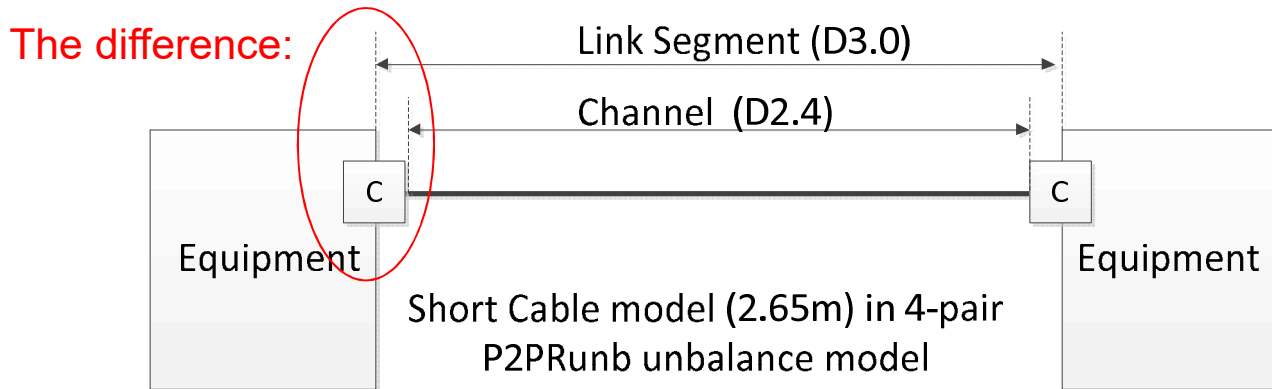

Analysis -1: Icon-2P_unb, Ipeak-2P_unb and ILIM-2P

- In both concepts for short and long cable models, the total number of connectors and cable length from where the end-to-end pair-to-pair resistance unbalance is defined (see figure 145-22), are the same.
- ***As a result the following parameters will not be changed:***
 - Icon-2P_unb
 - Ipeak-2P_unb
 - ILIM-2P

Analysis - 2: Effect on link section P2PRunb in 145A-2

- In the channel concept (D2.4), we had 0 to 4 connectors, cordage and cable up to 100m. Per TIA spec, this was resulted with R_{ch_unb} of 7% or 0.1Ω whichever is greater unbalance.
 - The 0.1Ω value is obtained at short channel length cable when the connectors resistance unbalance are dominant.
- In the link section concept we have additional 2 plugs
- Calculating the effect of changing to link section has negligible effect on TIA specifications for 145A-2.

(*) See page 4 in:

<http://www.ieee802.org/3/bt/public/unbaladhoc/Channel%20Pair%20To%20Pair%20Resistance%20Unbalance%20Specification-What%20is%20the%20preferred%20concept.pdf>

- ***Conclusion:***
No need to change unbalance numbers in 145A.2 (link section pair-to-pair unbalance) in D3.0.

Analysis - 3A: Compliance Requirements and verification tools

- Since the PSE PI and PD PI doesn't include connector plug per the link section definition used in D3.0, the following equations and tables will have to be updated per the new definitions:
 - **Equation 145-15 ($R_{pse_min/max}$)**
 - **Equation 145-26 ($R_{pd_min/max}$)**
 - **Table 145-17 ($R_{load_min/max}$).**
 - **Equation 145-27 ($R_{source_min/max}$)**
- **Doing the above will cause other issues that will make the use P2PRunb requirements harder to define and harder to test for compliance.**
- The resistance unbalance requirements for PSE PI and PD PI:
 - Will be tighter
 - Poor unbalance system budget allocation
 - Harder and complicated verification test models that needs to cancel the equipment jack resistance effects on unbalance.
 - Complicated associated unbalance text.

Analysis – 3B: Compliance Requirements and verification tools

- In reality, part of the connector, the jack, is in the equipment side and it has unbalance effect. The plug, can be in the “link section” however for unbalance specification ONLY, it was highly convenient that the equipment connectors will be at the equipment side as in D2.4.
- **Why?**
 - *The link section definition can stay as is.*
 - *The current spec is built in such a way that the test verification models (when PSE PI and PD PI have full connector on each side) have their own equivalent values for:*
 - *PSE load when PSE is tested and*
 - *PD connected to Vsource through Rsource when PD is tested.*
- *In order to keep the above objectives we just need to define that the equipment connector as part of the PSE PI and PD PI for P2PUnb spec requirements only.*
 - *This will result with no changes in the spec*

Conclusions

- The change we did from “channel” to “link section” will affect some unbalance requirements and verification models.
- It will be harder to define test verification models with link section definition.
- As a result we have two options to resolve these issues:
- **Option 1 (Preferred)**
- Keep using for P2P Runb requirements only the 4-pair system P2P Runb model based on the “channel” definition as defined in TIA and not the 4-pair model based on link section definition.
- The current verification models ($R_{source_min/max}$, $R_{load_min/max}$) has independent values and doesn't depend on the definition of link section or “channel”.
- *To add text to the spec that PSE PI and PD PI includes equipment connectors when evaluated for pair to pair unbalance.*
- **Option 2 (Not recommended.)**
- Redo the whole unbalance spec to fit with link section definitions

Proposed Baseline

Option 1:

(1) Specifying equipment connector as part of the PSE PI.

In 145.2.8.5.1 page 158, append to line 52:

“The PSE PI connector (jack) when mated with a specified balanced cabling connector (plug) shall meet the requirements of 145.2.8.5.1”

(2) Specifying equipment connector as part of the PD PI.

In 145.3.8.10 page 195, append to line 35:

“The PD PI connector (jack) when mated with a specified balanced cabling connector (plug) shall meet the requirements of 145.3.8.10”

Option 2: Need to redo whole work. Not recommended, no clear value.



Thank You

Annex A – 4-pair specification model per D2.4

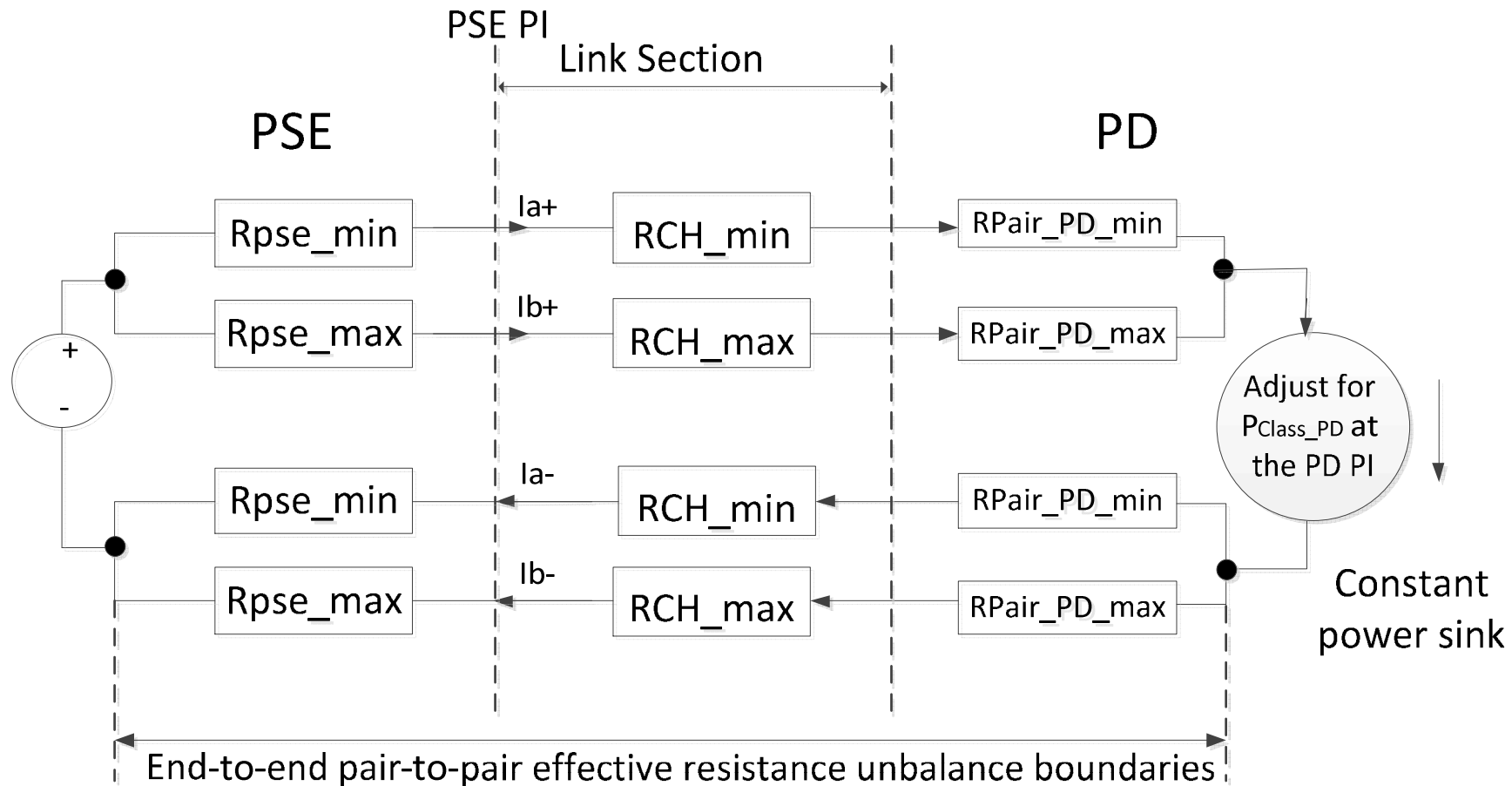

- All the unbalance pair-to-pair requirements in D3.0 where derived from this model. The details of the components used in this model are shown in Annex B.

Annex B1 – 4-pair detailed model for 2.4

- Spice simulations

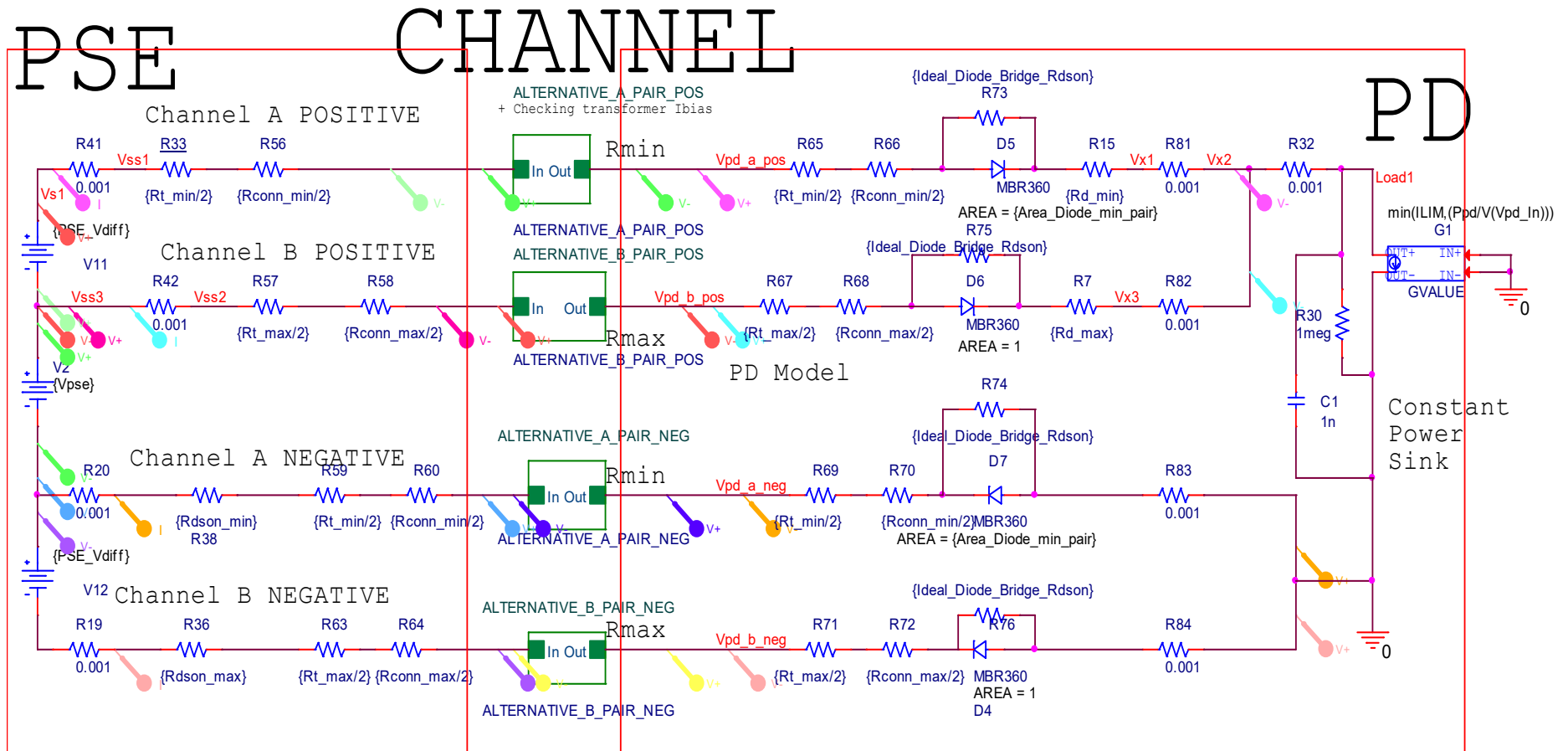

Annex B2 – 4-pair detailed model for D.2.4

- Part of the link section model (the channel including the equipment connectors)

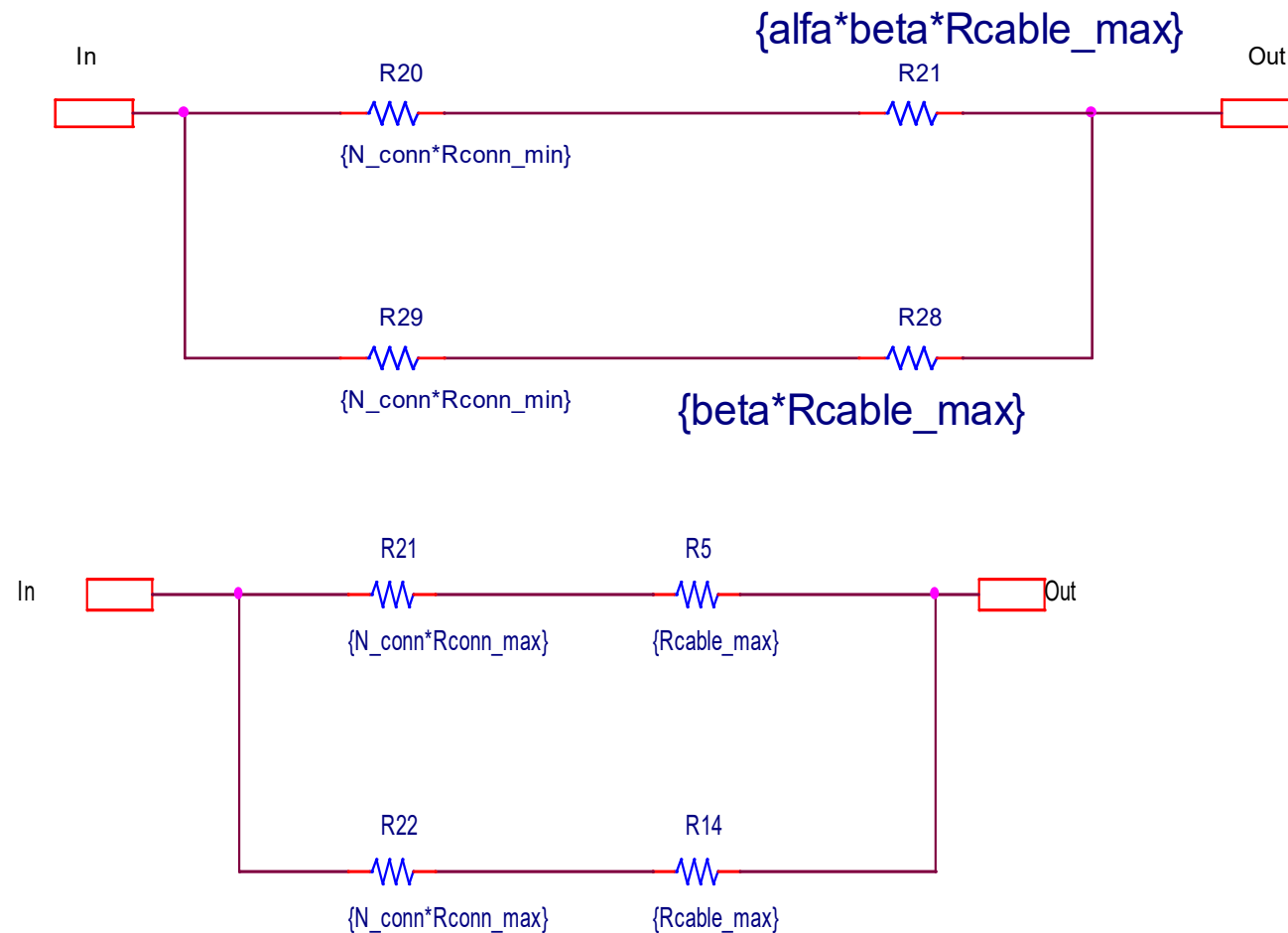

Annex B3 – 4-pair detailed model for D.2.4/D3.0

Cable Length (m)	2.65m	100m	Spec in 3.0	Notes
Channel max common mode resistance (Ω)	0.2	12.5		It is the value of two conductors in parallel from PSE PI to PD PI and back.
Number of connectors	2	6		
PSE Vdiff (mV)	10	10		
PD Vdiff (mV)	60	60		Diode to diode VF difference. VF is specified at 10mA. As a result PD_Vdiff is specified at 10mA. All unbalance requirements based on this PD_Vdiff limitations. PD_Vdiff effect on the system pair to pair unbalance is decreased from 60mV at 10mA (DC disconnect current levels. At this values P2PRunb is limited to 60% to 80%) to lower unbalance when current is increased at the levels of PClass-PD due to the compensation effect of the resistive elements. Failing to meet PD_Vdiff at low current will cause failures to meet I _{con-2P_unb} when diodes are used in the PD diode bridge function.
Pair with maximum current (mA) on (I(R41))	I _{max} ,	I _{max} ,	I _{max} = I _{cont_2P_unb}	Positive pairs