

From CLASS SD (TBD tie-in via Classification SD updates)

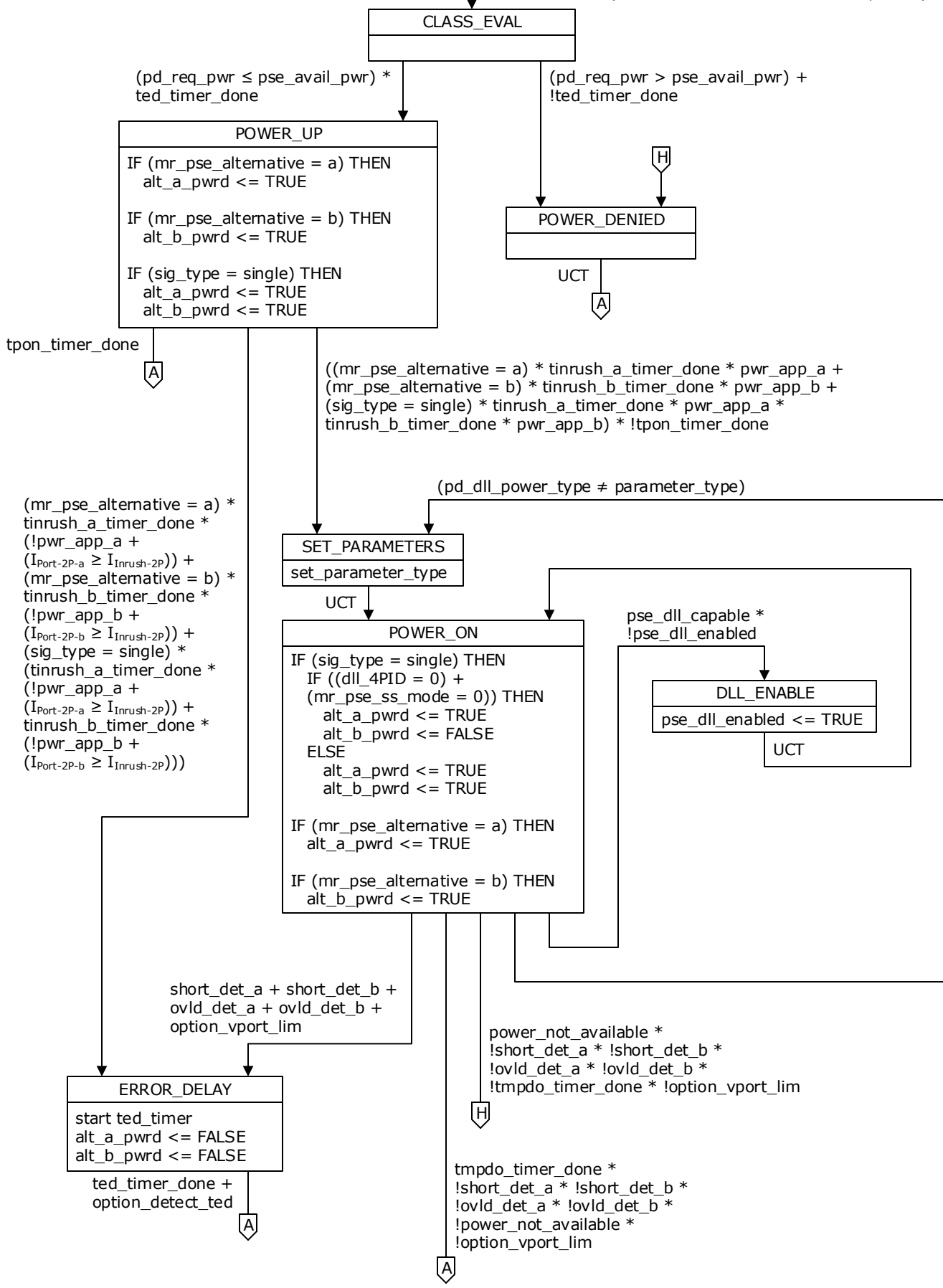

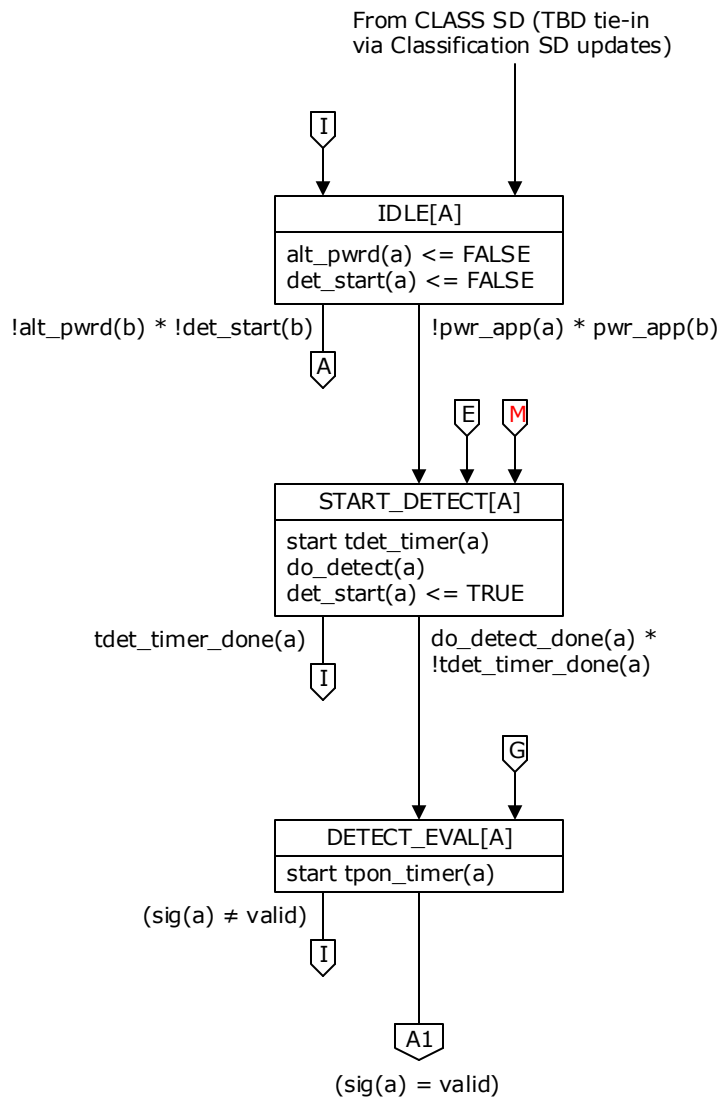

From CLASS SD (TBD tie-in via Classification SD updates)

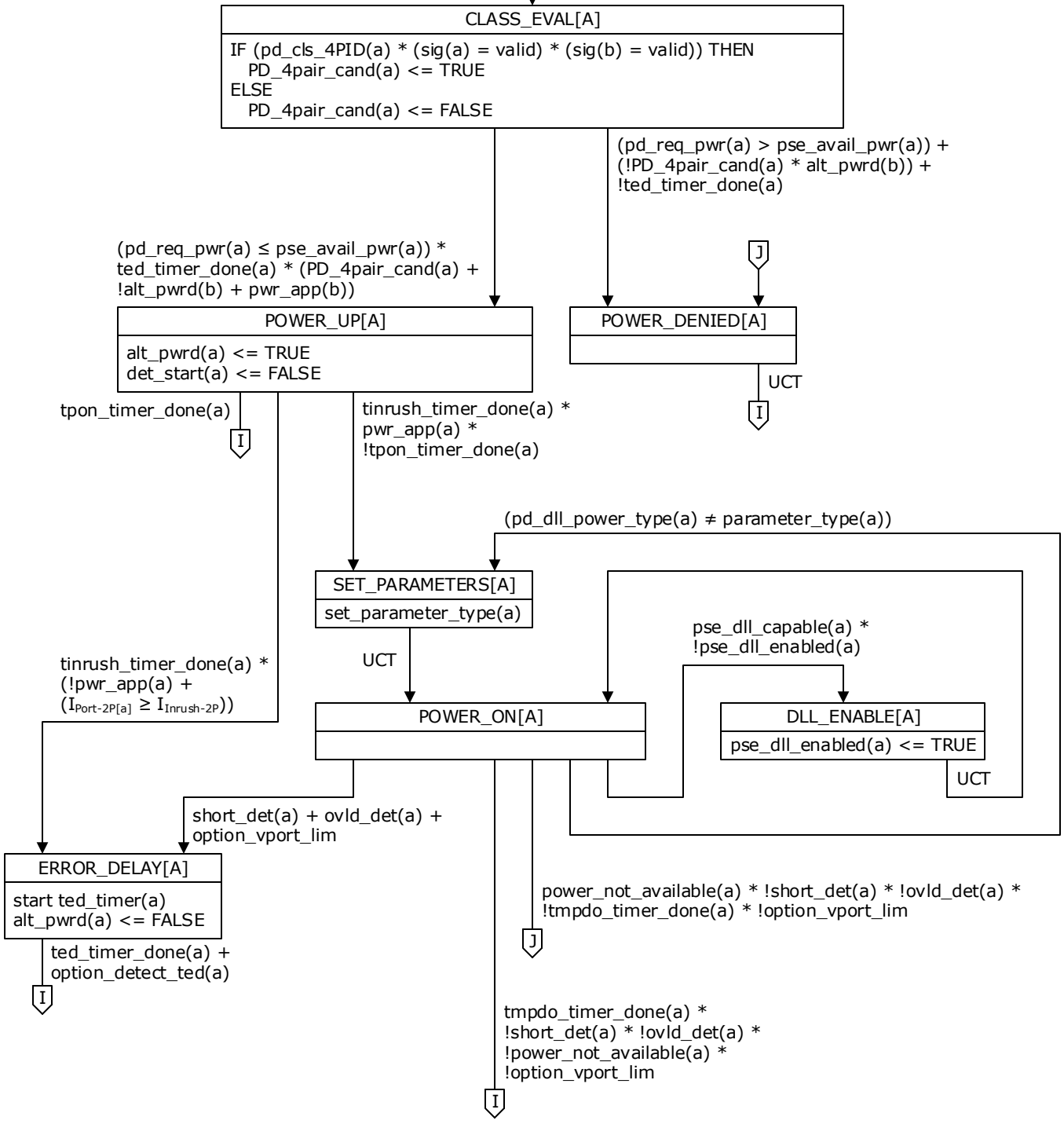

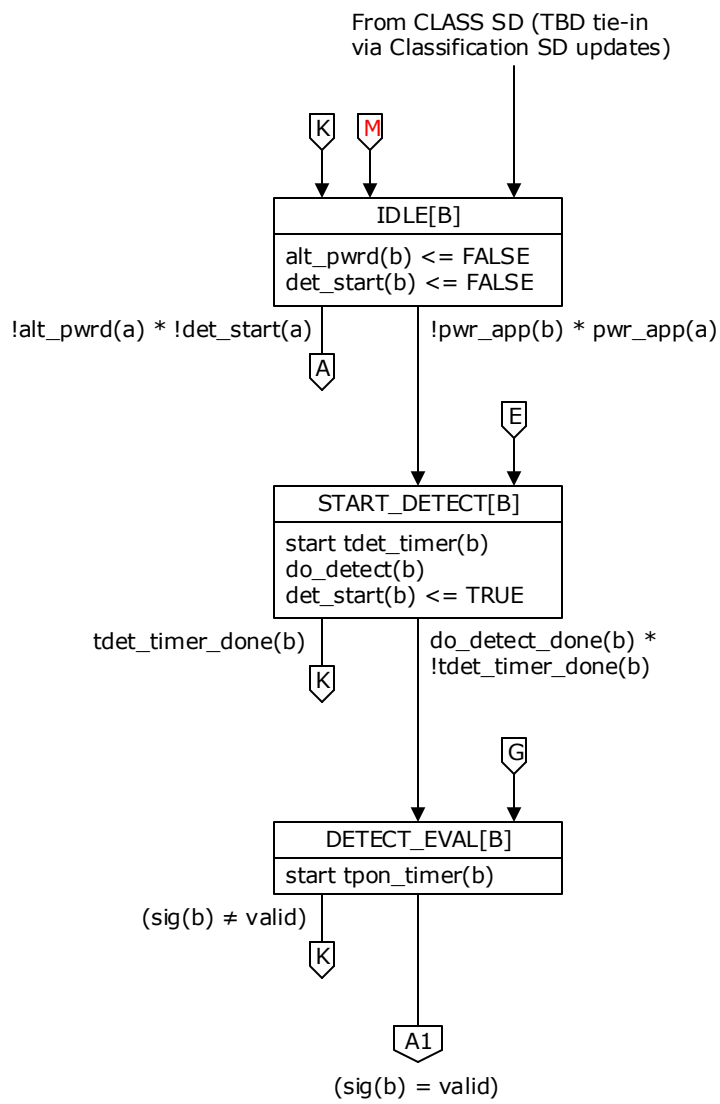

From CLASS SD (TBD tie-in via Classification SD updates)

