

1 Comment

2 D2.3 (#111, #131, #181, #322, #214, #333, #369).

- 3 1. The case when channel resistance is less than 0.2 ohm is addressed in 145.2.8.5.1. Therefore, the text
4 that link this use case to Annex 145A.1 was deleted.
- 5 2. Some text is missing from the approved baselines darshan_01_0117_Rev007 and
6 darshan_05_0116Rev005.pdf. This text is marked by **YELLOW marker** and inserted back.
- 7 3. The whole Annex 33A.5 with the changes made by the approved remedy darshan_05_0116Rev005.pdf
8 is missing.
- 9 4. We need to keep the following concept for the unbalance variable names to keep consistency:
10 Rpse_min/max is PSE PI effective resistance.
11 RPD_min/max is the PD PI effective resistance (Currently it is Rpair_pd_min/max).
12 Nominal PI resistances will be: Rpair_PSE_min/max and Rpair_PD_min/max.
13 (Rpd is not used anywhere. We have only Rpd_d in detection section.)

14 Suggested Remedy:

Baseline starts here

15 ~~Modify the text per the proposed baseline:~~

- 16 *1. Editor please note: Some text is missing from the approved baselines*
17 *darshan_01_0117_Rev007 and darshan_05_0116Rev005.pdf. This text is*
18 *marked by **YELLOW marker** and inserted back.*
- 19 *2. Modify the text per the proposed baseline:*

20 145.2.8.5.1 PSE PI pair-to-pair effective resistance and current unbalance

21 PSEs that operate over 4-pairs are subject to unbalance requirements. The contribution of PSE PI pair-to-pair
22 effective resistance unbalance to the system end to end effective resistance unbalance, is specified by PSE
23 maximum (RPSE_max) and minimum (RPSE_min) common mode effective resistance in the powered pairs of
24 same polarity. See Figure 145-22.
25 Effective resistances of RPSE_min and RPSE_max include the effects of VPort_PSE_diff as specified in Table
26 145-16 and the PSE PI resistive elements. See definition and measurements in Annex 145A.

27 The PSE PI pair-to-pair effective resistance unbalance determined by RPSE_max and RPSE_min ensures that
28 along with any other parts of the system, i.e. channel (cables and connectors) and the PD, the pairset with the
29 highest current including unbalance does not exceed ICon-2P-unb as defined in Table 145-16 during normal
30 operating conditions. ICon-2P-unb is the current in the pairset with the highest current in the case of
31 maximum unbalance and will be higher than ICon/2. ICon-2P-unb applies for total channel common mode
32 pair resistance from 0.2 Ω to RCh, as defined in 145.1.3. ~~For channels with common mode pair resistance~~
33 ~~lower than 0.2 Ω , see 145A.1.~~

This is not part of the baseline

The following text "The sum of RCh_unb_min and RCh_unb_max is RChan-2P as described in Figure 145-22 ..."
was moved to after Table 145-17

34 ~~The sum of RCh_unb_min and RCh_unb_max is RChan-2P as described in Figure 145-22 and as defined by the~~
35 ~~pair to pair channel resistance unbalance requirement for 4 pair operation in 33A.4.~~

36 RPSE_max and RPSE_min are specified and measured under maximum PClass_PD load conditions, measured at
37 the PD PI, over the VPort_PSE-2P operating range. ~~Conformance with Equation (145-15) shall be met for~~
38 ~~RPSE_max and RPSE_min.~~ RPSE_max and RPSE_min for the positive pairs are not necessarily the same values as
39 for the negative pairs.

40 [The relation between RPSE_max and RPSE_min, as defined by equation 145-15 makes the PSE meet its](#)
41 [unbalance requirements under worst case conditions of channel pair to pair unbalance and PD PI pair to pair](#)
42 [unbalance. PSEs that comply with Equation \(145-15\) intrinsically meet unbalance requirements.](#)

$$0 < R_{PSE_max} \leq \begin{cases} 2.182 \times R_{PSE_min} - 0.040 & \text{for Class 5} \\ 1.999 \times R_{PSE_min} - 0.040 & \text{for Class 6} \\ 1.904 \times R_{PSE_min} - 0.030 & \text{for Class 7} \\ 1.832 \times R_{PSE_min} - 0.030 & \text{for Class 8} \end{cases} \quad 145-15$$

where

RPSE_max is, given RPSE_min, the highest allowable common mode effective resistance in the powered pairs of the same polarity.
 RPSE_min is the lower PSE common mode effective resistance in the powered pairs of the same polarity.

R_{PSE_C} common mode effective resistance is the resistance of the two wires-conductors (including and their components on each conductor) in a powered-pair of the same polarity connected in parallel.

This is not part of the baseline

- 1- Some lines moved up for correct order of topics.
- 2- The link to Annex 145X (was Annex 33A.5 that was not implemented per darshan_05_0116Rev005.pdf) is missing and restored. It is marked with YELLOW marker.

Figure 145-22 illustrates the relationship between RPSE_max and RPSE_min effective resistances at the PSE PI as specified by Equation 145-15 and the rest of the end to end pair to pair effective resistance components.

~~PSEs that comply with Equation (145-15) intrinsically meet unbalance requirements. [This text was moved up]~~

~~Figure 145-22 illustrates the relationship between RPSE_max and RPSE_min effective resistances at the PSE PI as specified by Equation 145-15 and the rest of the end to end pair to pair effective resistance components.~~

A PSE shall not source more than Icon-2P_unb min on any pair when connected to a load as shown in Figure 145-42, using values of Rload_min and Rload_max as specified in ~~Table 145-17~~ Equation 145-16 and Equation 145-17.

Table 145-17—Rload_max and Rload_min requirements

PSE Class	Rch_unb_min, (Ω)	Rch_unb_max, (Ω)	R _{Pair_PD_min} RPD_min, (Ω)	R _{Pair_PD_max} RPD_max, (Ω)	Rload_min, (Ω)	Rload_max, (Ω)	Additional Information
5	0.087	0.101	0.641	1.524	0.728	1.624	Rload is at Low channel resistance conditions. All resistances within ±1% range.
6			0.541	1.187	0.628	1.288	
7			0.486	1.020	0.573	1.121	
8			0.441	0.896	0.529	0.996	
5	5.405	6.250	0.708	1.031	6.113	7.281	Rload is at High channel resistance conditions. All resistances within ±1% range.
6			0.567	0.826	5.972	7.076	
7			0.494	0.720	5.898	6.970	
8			0.432	0.630	5.837	6.882	

Rload_min and Rload_max, defined in Equation 16 and Equation 17 Table 145-17, are respectively the minimum and maximum common mode effective load resistances in the powered pairs of the same polarity.

R_{Pair_PD_min} RPD_min and R_{Pair_PD_max} RPD_max are respectively the minimum and maximum common mode effective PD PI resistances. They account for the effective resistance of resistive elements combined with PD pair to pair voltage difference and the effect of system end to end pair to pair resistance unbalance. See Annex 145X.

1 Rch_unb_min ~~Rehunb_min~~ and Rch_unb_max ~~Rehunb_max~~ are respectively the minimum and maximum
 2 common mode channel resistances in the powered pairs of the same polarity from PSE PI to PD PI per the
 3 model described in Figure 145A-2.

4 The sum of RCh_unb_min and RCh_unb_max is RChan-2P as described in Figure 145-22 and as defined by the
 5 pair-to-pair channel resistance unbalance requirement for 4-pair operation in 33A.4-145A.4.

6 ~~Table 145-17 specifies the values of Rload_min and Rload_max components according to~~
 7 ~~Equations 145-16 and Equation 145-17.~~

8 ~~[This text was moved below Equations 145-16 and 145-17] The values of RPair_PD_min and~~
 9 ~~RPair_PD_max are given to allow calculations and measurement of PClass_PD at the PD PI.~~

10
 11
$$Rload_min = \del{RPair_PD_min} RPD_min + \del{Rehunb_min} \del{Rch_unb_max} \quad (145-16)$$

12
 13
$$Rload_max = \del{RPair_PD_max} RPD_max + \del{Rehunb_max} \del{Rch_unb_max} \quad (145-17)$$

14
 15 The values of ~~RPair_PD_min~~ RPD_min and ~~RPair_PD_max~~ RPD_max are given to allow
 16 calculations and measurement of PClass_PD at the PD PI.

17
 18 Figure 145-22 shows a verification circuit for the current unbalance requirements measurement.

19 Other methods for measuring RPSE_min and RPSE_max are described in Annex 145-A.

20
 21 ICon-2P-unb and Equation (145-15) are specified for total channel common mode pair resistance RChan-2P
 22 from 0.2 Ω to 12.5 Ω and worst case unbalance contribution by a PD. PSEs that support channel common
 23 mode resistance less than 0.2 Ω, or if RChan is less than 0.1 Ω, the PSE should meet ICon-2P-unb
 24 requirements when connected to (Rload_min - 0.5 × RChan-2P) and (Rload_max - 0.5 × RChan-2P). This
 25 can be achieved by using a lower RPSE_max or higher RPSE_min than required by Equation (145-15).
 26 Lower RPSE_max values may be obtained by using smaller constant α or higher RPSE_min in Equation
 27 (145-15) in the form of ~~RPSE_max~~ RPSE_max = α × RPSE_min + β.

29

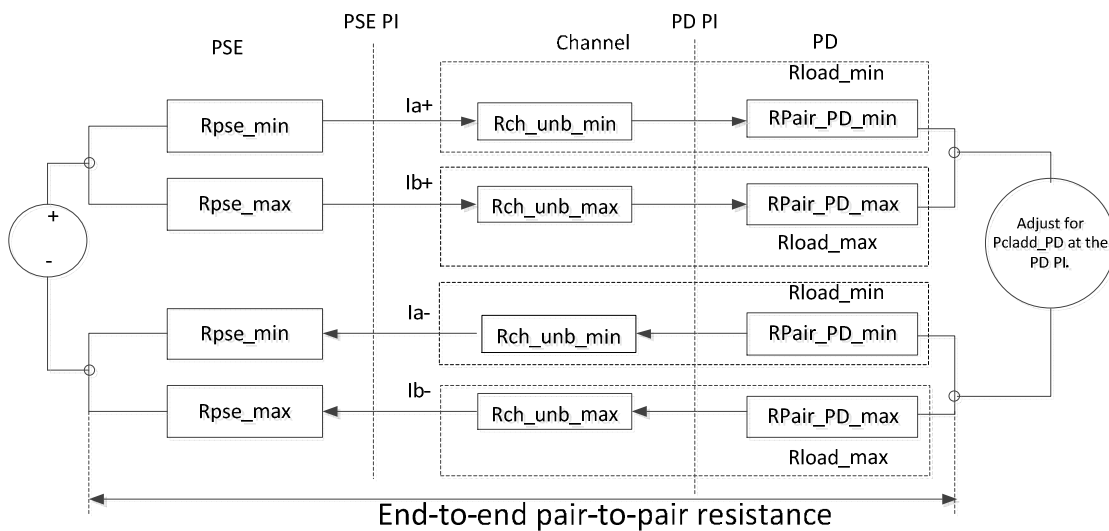

30

31

32 **Figure 145-22—PSE PI unbalance specification and E2EP2PUnb**

33 The evaluation method is as follows:

34

- 35 a) Use Rload_min and Rload_max from Table 145-17 for ~~Rload at~~ low channel resistance conditions.
- 36 b) With the PSE powered on, adjust the load to PClass_PD.
- 37 c) Measure Ia+, Ib+, Ia-, and Ib-.
- 38 d) Exchange Rload_max and Rload_min. Repeat steps b) and c).
- 39 e) Verify that the current in any pair does not exceed ICon-2P-unb, as defined in Table 145-16.

1 f) Repeat steps b) through e) for Rload_min and Rload_max from Table 145-17 ~~for Rload~~ at high channel
 2 resistance conditions.

3
 4 **145A.3 Intra pair resistance unbalance**

5 Operation for all PSE and PD Types requires that the resistance unbalance be 3% or less. Resistance
 6 unbalance is a measure of the difference between the two conductors of a twisted pair in the 100 Ω balanced
 7 cabling system. Resistance unbalance is defined as in Equation (145A-1):

8
$$Runb = \left\{ \frac{(R_{max} - R_{min})}{(R_{max} + R_{min})} \times 100 \right\} \% \quad (145A-1)$$

9 where

10 R_{max} is the resistance of the pair conductor with the highest resistance

11 R_{min} is the resistance of the pair conductor with the lowest resistance.

12
 13 **145A.4 Pair-to-pair channel resistance unbalance requirement for 4-pair operation**

14 Operation using 4-pair requires the specification of resistance unbalance between each two pairs of the
 15 channel, not greater than 100 milliohm or resistance unbalance of 7% whichever is a greater unbalance.

16 Resistance unbalance between the channel pairs is a measure of the difference of resistance of the common
 17 mode pairs of conductors used for power delivery. Channel pair-to-pair resistance unbalance is defined by
 18 Equation (145A-2).

19
 20
$$Rch_unb = \left\{ \frac{(Rch_unb_max - Rch_unb_min)}{(Rch_unb_max + Rch_unb_min)} \times 100 \right\} \% \quad (145A-2)$$

21

22 Channel pair-to-pair resistance difference is defined by Equation (145A-3):

23
$$Rdiff = \{ Rch_unb_max - Rch_unb_min \} \quad (145A-3)$$

24 where

25 Rch_unb_max is the sum of channel pair components with highest common mode
 26 resistance from PSE PI to PD PI.

27
 28 Rch_unb_min is the sum of channel pair components with lowest common mode
 29 resistance from PSE PI to PD PI.

30
 31 Channel ~~C~~common mode resistance is the resistance of the two conductors ~~wires in a pair~~ (including
 32 connectors) in a pair, connected in parallel.

33
 34 The resistance of the common mode pairs of conductors and connectors Rch_unb_min and Rch_unb_max are
 35 described by Figure 145A-2.

36
 37

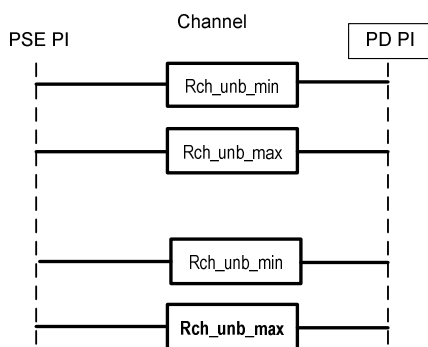

38

39 **Figure 145A-2** – Common mode Pair-to-pair channel resistance unbalance

40

41 Note: Each conductor in Figure 145A-2 is the equivalent of two conductors in parallel.

42

1 **Annex 145A**

2 (Informative)

3 **PSE PI pair-to-pair resistance/current unbalance**

4 **145A.1 Introduction**

5 End to end pair-to-pair resistance/current unbalance (E2EP2P_{runb}) refers to current differences in powered
6 pairs of the same polarity. Current unbalance can occur in positive and negative powered pairs when a PSE
7 uses all four pairs to deliver power to a PD.

8 Current unbalance requirements (RPSE_{min}, RPSE_{max} and Icon-2P_{unb}) of a PSE **shall be** met with
9 Rload_{max} and Rload_{min} as specified in Table 145-17.
10

11 A compliant unbalanced load, Rload_{min} and Rload_{max} consists of the channel (cables and connectors), and
12 PD effective resistances, including the effects (*or influence*) of PSE PI effective resistance as a function of
13 the system end-to-end unbalance.
14

15 Equation (145–15) is described in 145.2.8.5.1, specified for the PSE, assures that E2EP2P_{runb} will be met in
16 the presence of all compliant, unbalanced loads (Rload_{min} and Rload_{max}) attached to the PSE PI.

17 Figure 145-22 illustrates the relationship between effective resistances at the PSE PI as specified by Equation
18 (145–15) and Rload_{min} and Rload_{max} as specified in Table 145-17.
19

20 There are two alternate verification methods for RPSE_{max} and RPSE_{min} and determining conformance to
21 Equation (145–15) and to Icon-2P_{unb}.
22

23 Measurement methods to determine RPSE_{max} and RPSE_{min} and Icon-2P_{unb} are defined in 145A.2 and
24 145A.3.
25

26 **145A.2 Direct RPSE measurement**

27 If there is access to internal circuits, effective resistance may be determined by sourcing current in each path
28 corresponding to maximum PClass operation, and measuring the voltage across all components that contribute
29 to the effective resistance, including circuit board traces and all components passing current to the PSE PI
30 output connection. The effective resistance is the measured voltage V_{eff}, divided by the current through the
31 path e.g. the effective value of RPSE_{min} for i1 is $RPSE_{min} = V_{eff1}/i1$ as shown in Figure 145A-1.

32 [RPSE_{min} and RPSE_{max} values respectively may be diferent than Rpair_pse_min and Rpair_pse_max](#)
33 [values.](#)

34

35 **Update Figure 145A-1as follows:**

36 **Change Rpair_{min} to Rpair_pse_min**

37 **Change Rpair_{max} to Rpair_pse_max**

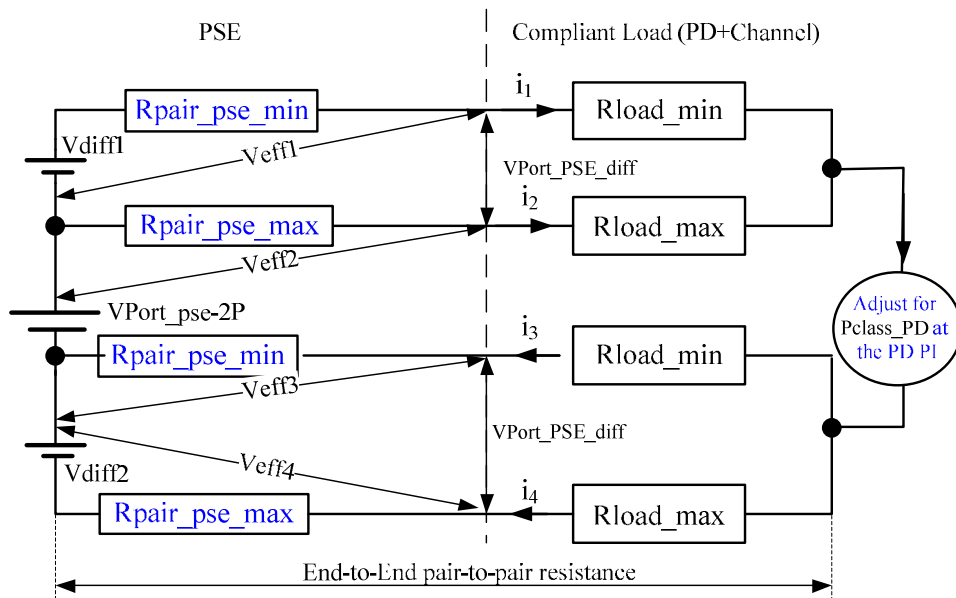

Figure 145A-1—Direct measurements of effective RPSE_max and RPSE_min

145A.3 Effective resistance Rpse measurement

Figure 145A-2 shows a possible verification circuit for effective resistance measurements on a PSE port for evaluating conformance to Equation (145-15) if the internal circuits are not accessible. In Figure 145A-2, the positive pairs of the same polarity are shown as an example. The same concept applies to the negative pairs.

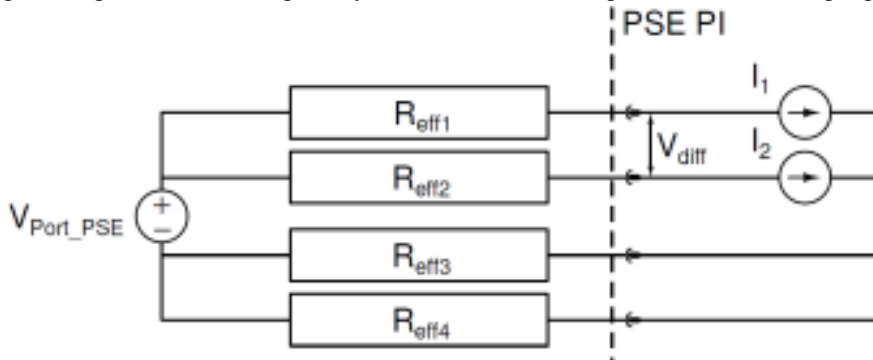

Figure 145A-2 – Effective resistance verification circuit

The Effective Resistance verification Procedure is described below:

- 1) With the PSE powered on, set the following current values
 - a. $10 \text{ mA} < I_2 < 50 \text{ mA}$
 - b. $I_1 = 0.5 \times (P_{\text{max}}/V_{\text{port}}) - I_2$
- 2) Measure V_{diff} .
- 3) Reduce I_1 by 20% ($=I_1'$). Ensure I_2 remains unchanged.
- 4) Measure V_{diff}' in the same manner as V_{diff} .
- 5) Calculate R_{eff1} : $R_{\text{eff1}} = [(V_{\text{diff}}) - (V_{\text{diff}}')] / (I_1 - I_1')$
- 7) Repeat procedure for R_{eff2} , with I_1, I_2 values swapped.
- 8) Repeat procedure for $R_{\text{eff3}}, R_{\text{eff4}}$.
- 9) Evaluate compliance of R_{eff1} and R_{eff2} with Equation (145-15). Evaluate compliance of R_{eff3} and R_{eff4} with Equation (145-15).

The effective resistance verification method applies to the general case. If pair-to-pair balance is actively controlled in a manner that changes effective resistance to achieve balance, then the current unbalance measurement method described in 145.2.8.5.1 shall be used.

1 PD Section

This is not part of the baseline

-In the following text, referenced will be made to Annex 145X which was Annex 33A.5 in D2.2 and was not implemented as approved by darshan_05_0116Rev005.pdf and is missing from D2.2. Annex 145X is added later in this document.

-The parts that are marked with YELOW marker are parts that was approved in darshan_05_0116Rev005.pdf and was not implemented.

2

3

145.3.8.10 PD pair-to-pair current unbalance

4

5

This section describes unbalance requirements for PDs that operate over 4-pair. The contribution of PD PI pair-to-pair effective resistance unbalance to the effective system end to end resistance unbalance, is determined by PD maximum (~~R_{Pair_PD_max}~~R_{PD_max}) and minimum (~~R_{Pair_PD_min}~~R_{PD_min}) common mode effective resistance in the powered pairs of same polarity. ~~See Figure 33A-2~~ See Figure 145X-1.

10

Effective resistances of ~~R_{Pair_PD_min}~~R_{PD_min} and ~~R_{Pair_PD_max}~~R_{PD_max} include the effects of PD pair to pair voltage difference and the PD PI resistive elements. See definition and measurements in Annex 145X.

12

13

14

~~R_{PD_max}~~ ~~R_{Pair_PD_max}~~ is given ~~R_{Pair_PD_min}~~, defined in Equation (145-31) for a given R_{PD_min}, is the highest allowable common mode effective resistance in the powered pairs of the same polarity. PDs that meet Equation (145-31) intrinsically meet unbalance requirements.

17

Change:

18

~~R_{pair_PD_max}~~ and ~~R_{pair_PD_min}~~ to R_{PD_max} and R_{PD_min} in Equation 145-31.

19

20

$$0 < R_{PD_max} \leq \left\{ \begin{array}{ll} 2.17 \times R_{PD_min} + 0.125 & \text{for PD Type 3, Class 5} \\ 1.988 \times R_{PD_min} - 0.105 & \text{for PD Type 3, Class 6} \\ 1.734 \times R_{PD_min} + 0.08 & \text{for PD Type 4, Class 7} \\ 1.727 \times R_{PD_min} + 0.074 & \text{for PD Type 4, Class 8} \end{array} \right\}_{\Omega} \quad (145-31)$$

21

where

22

~~R_{Pair_PD_max}~~R_{PD_max} is, given ~~R_{Pair_PD_min}~~R_{PD_min}, the highest allowable common mode effective resistance in the powered pairs of the same polarity.

23

24

25

~~R_{Pair_PD_min}~~R_{PD_min} is the lower PSE common mode effective resistance in the powered pairs of the same polarity.

26

27

28

R_{pd} common mode effective resistance is the effective-resistance of the two conductors wires (including their components on each conductor) and their components in a powered pair of the same polarity connected in parallel.

30

31

32

Smaller constants α and β in the equation $R_{PD_max} = \alpha \times R_{PD_min} + \beta$ ensure that I_{Con-2P-unb} is not exceeded for PD power consumption above the values in Table 145-26.

33

34

35

Figure 145X-1 illustrates the relationship between R_{PD_max} and R_{PD_min} effective resistances at the PD PI as specified by Equation 145-31 and the rest of the end to end pair to pair effective resistance components.

36

37

38

Under all operating states, single-signature PDs assigned to Class 5 or higher shall not exceed I_{Con-2P-unb} for longer than TCUT-2P min as defined in Table 145-16 on any pair when PD PI pairs of the same polarity are connected to all possible common source voltages in the range of V_{Port_PSE-2P} through two common mode resistances, R_{source_min} and R_{source_max}, as defined by Equation (145-32) and shown in Figure 145-34.

42

43

44

Under all operating states, dual-signature PDs shall not exceed I_{Con-2P} as defined in Equation (145-8) for longer than TCUT-2P min as defined in Table 145-16 on any pair when PD PI pairs of the same polarity are

45

1 connected to all possible common source voltage in the range of VPort_PSE-2P through two common mode
 2 resistances, Rsource_min and Rsource_max, as defined in Equation (145-32) and shown in Figure 145-34.
 3

$$R_{source_max} = \left\{ (-0.03 \times R_{source_min} + 1.324) \times R_{source_min} \text{ for } (0.145\Omega \leq R_{source_min} \leq 5.47\Omega) \right\}_{\Omega} \quad (145-32)$$

4
 5
 6 Rsource_min and Rsource_max represent the Vin source common mode effective resistance that
 7 consists of the PSE PI components (RPSE_min and RPSE_max as specified in 145.2.8.5.1,
 8 VPort_PSE_diff as specified in Table 145-16, the channel resistance, and influence of
 9 ~~RPair_PD_min~~RPD_min and ~~RPair_PD_max~~RPD_max as function of system end-to-end
 10 unbalance). Common mode effective resistance is the resistance of two con-ductors of the same pair
 11 and their other components, which form Rsource, connected in parallel including the effect of the
 12 total system (PSE and PD) pair to pair voltage-difference. IA and IB are the pair currents of pairs
 13 with the same polarity.

14
 15 ~~RPair_PD_min~~RPD_min, ~~RPair_PD_max~~RPD_max ensures that along with any other parts of the
 16 system, i.e. channel (cables and connectors) and the PSE, the maximum pair current including
 17 unbalance does not exceed ICon-2P-unb as defined in Table 145-16 during normal operating
 18 conditions. [See Annex 145X](#).

19

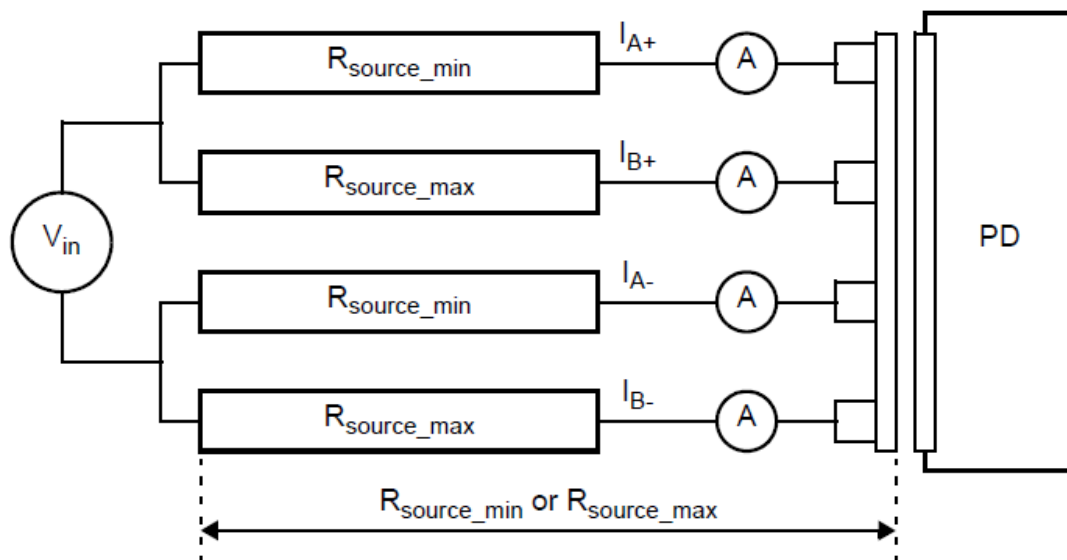

Figure 145-34— I_{Con-2P} and $I_{Con-2P-unb}$ evaluation model

20

21 [\[Note 1 was changed to address comment #322. Note 2 cannot be changed\]](#)

22 NOTE 1—Rsource in Figure 145-34 includes [the connecting hardware resistance](#) ~~resistance~~ ~~Reon~~ ~~of~~
 23 [the evaluation model to the PD](#) which ~~its~~ ~~is~~ ~~the~~ ~~connection~~ ~~resistance~~ ~~at~~ ~~the~~ ~~PD~~. The maximum
 24 recommended [value](#) ~~is~~ ~~Reon~~ ~~value~~ is 0.02 Ω .

25 NOTE 2—The pairset current limits should also be met when Rsource_max and Rsource_min are
 26 swapped between pairs of the same polarity.

27

28

This is not part of the baseline

-Annex 145A.5 (which was Annex 33A.5 in D2.2) is missing from D2.3 and need to be inserted in the next draft per the approved changes made to it by darshan_05_0116Rev005.pdf from January 2017.

-The following is darshan_05_0116Rev005.pdf with new updates for D2.3 regarding using RPD_min/max instead of Rpair_PD_min/max in the text and in the drawings.

- Copy the following text and drawing into Annex 145X (used to be Annex 33A.5 in D2.2).
- Approved Changes in Figure 145X-1 from D2.2 to D2.3 are marked with RED color.
- New Changes in Figure 145X-1 from D2.3 to next draft are marked with BLUE color.

Annex 145X

(Informative)

PD PI pair-to-pair current unbalance requirements

RPD_max and RPD_min represent PD common mode input effective resistance of pairs of the same polarity.

Common mode effective resistance is the resistance of two conductors of the same pair and their other components connected in parallel including the effect of PD pair-to-pair voltage difference of pairs with the same polarity (e.g. Vf1-Vf3). The common mode effective resistance R_n is the measured voltage $V_{eff_pd_n}$, divided by the current through the path as described below and as shown in the example in Figure 145X-1, where n is the pair number.

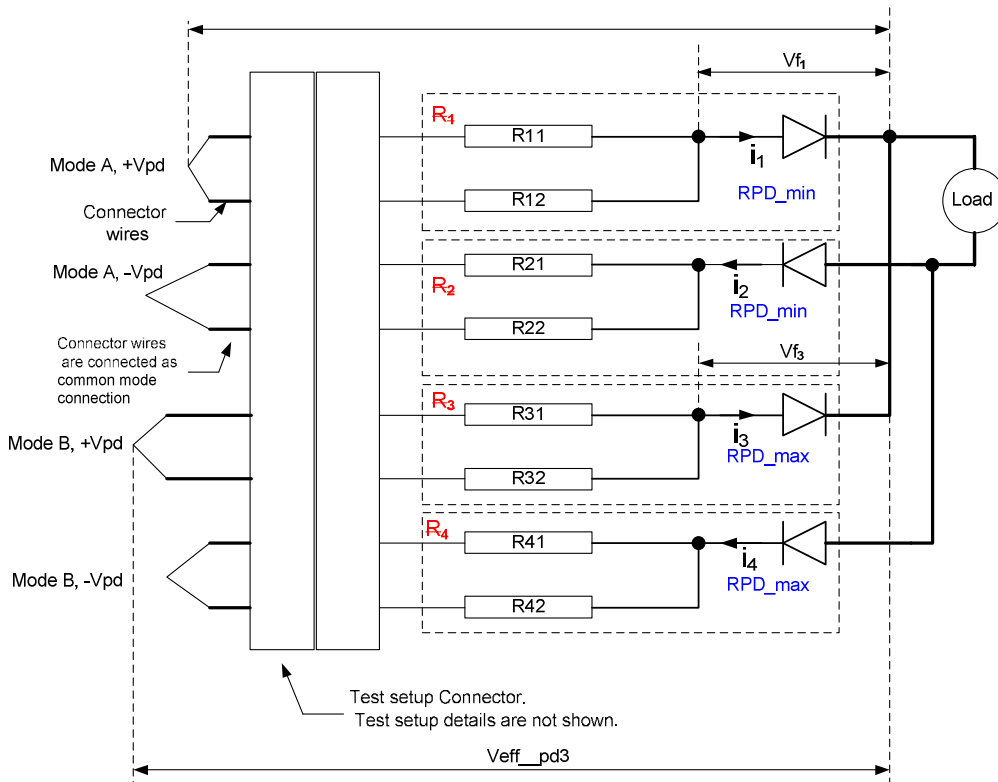

Figure 145X-1—PD resistance unbalance elements overview

Positive pairs:

$$RPD_{min} = V_{eff_pd1} / i_1$$

$$RPD_{max} = V_{eff_pd3} / i_3$$

Negative pairs:

$$RPD_{min} = V_{eff_pd2} / i_2$$

$$RPD_{max} = V_{eff_pd4} / i_4$$

End Of proposed baseline

- 1 **Annex A: 4-pairs spice simulation model parameters used to specify IEEE802.3bt**
- 2 **D2.2 and D2.3 requirements.**
- 3 The following values of the 4-pair model were used to set the specification requirements of the PSE PI and the PD PI
- 4 unbalance requirements as a function of the total system end to end pair to pair effective resistance/current unbalance.

#	Parameter	Units	Class 5-6		Class 7-8		Notes	
			Min	Max	Min	Max		
1	Vpse	Vdc	50.31	----	52.31	----	PSE voltage source, no load voltage	
2	Ppd	W	40, 51	----		----	PD input power measured at the PD PI	
3	Ppd extended power	W	59.7	----	89.4	----	PD input power measured at the PD PI	
4	Lcable	m	2.65	100	2.65	100	Cable and cordage length.	
5	Diode AREA2	-	10		10		Diode simulation parameter. Set the PD Vdiff compare to the diode in the pair with minimum resistance that is set to AREA=1. As a result, PD Vdiff is set to $V_{diff}=(n \cdot k \cdot T/q) \cdot \ln(I_{s2}/I_{s1})$ while $I_{s2}=I_{s1}$ (same diodes only AREA parameter is changed). As a result, AREA2/AREA1 sets PD Vdiff. For AREA2=10 we will get PD Vdiff=60mV measured at IF=10mA (PD Vdiff is the pair to pair PD voltage difference caused by the forward voltage difference between two diodes on pairs of the same polarity. PD Vdiff is determined at low current (few mA range). When current increase the effect of PD Vdiff on the PD contribution to its PI unbalance and to the total system unbalance is reduced. The use of diodes with higher Vdiff, will increase the PD unbalance at high currents. Therefore a limit of 60mV for PD Vdiff was set at 10mA.	
	Diode AREA1	-	1	----	1		Diode simulation parameter set to AREA 1. This diode is located at the pair with maximum resistance.	
	Cordage Resistivity	Ω/m	0.0926	----	0.0926	----	Used for short channel length with Lcable =2.65m simulations	
	Cable resistivity	Ω/m	0.074	----	0.074	----	Used for short channel length with Lcable =2.65m simulations	
	Nuber of connectors	-	0	----	0	----	Used for short channel length with Lcable =2.65m simulations	
	Cordage Resistivity	Ω/m	0.123	Ω	0.123	----	Used for long channel length with Lcable =100m simulations	
	Cable resistivity	Ω/m	0.123	Ω	0.123	----	Used for long channel length with Lcable =100m simulations	
	Nuber of connectors	-	4	----	4	----	Used for long channel length with Lcable =100m simulations	
	Minimum Channel Resistance wire 1	Ω	$=\alpha \cdot \beta \cdot L_{cable} \cdot (0.1 \cdot \text{cordage_resistivity} + 0.9 \cdot \text{cable_resistivity}) + N \cdot R_{conn_min}$					1 st wire of the pair with minimum resistance $\alpha = (1 - \text{pair_Runb}) / (1 + \text{pair_Runb}) = 0.96$. Pair_Runb=0.02. $\beta = (1 - \text{pair2p_Runb}) / (1 + \text{pair2p_Runb}) = 0.9$. Pair2p_Runb=0.05 for IEEE802.3bt D2.1 and was changed to $\beta = (1 - \text{pair2p_Runb}) / (1 + \text{pair2p_Runb}) = 0.8867$. Pair2p_Runb=0.06 to ensure total channel pair to pair resistance unbalance of 7% per Annex 145A.4. Wire length is measured from PSE PI to PD PI (not round loop). Each pair of the same polarity has two wires (wire 1 and wire 2) are connected in parallel and form common mode resistance of that pair. In the positive pairs, we have two pairs with the same voltage polarity, the 1 st pair is set to minimum resistance and the 2 nd pair is set to maximum resistance. The same applies to the negative pairs.
	Minimum Channel Resistance wire 2	Ω	$=\beta \cdot L_{cable} \cdot (0.1 \cdot \text{cordage_resistivity} + 0.9 \cdot \text{cable_resistivity}) + N \cdot R_{conn_min}$					
	Maximum Channel Resistance wire 1 and wire 2		$L_{cable} \cdot (0.1 \cdot \text{cordage_resistivity} + 0.9 \cdot \text{cable_resistivity})$					
	PSE Vdiff	mV	10	----	10	----		
	Rt	Ω	0.12	0.13	0.12	0.13	Transformer winding resistance	
	Rconn	Ω	0.03	0.05	0.03	0.05	Connector resistance	
	Rdson	Ω	0.07	0.1	0.07	0.1		
	Rsense	Ω	0.0225	0.25	0.0225	0.25		

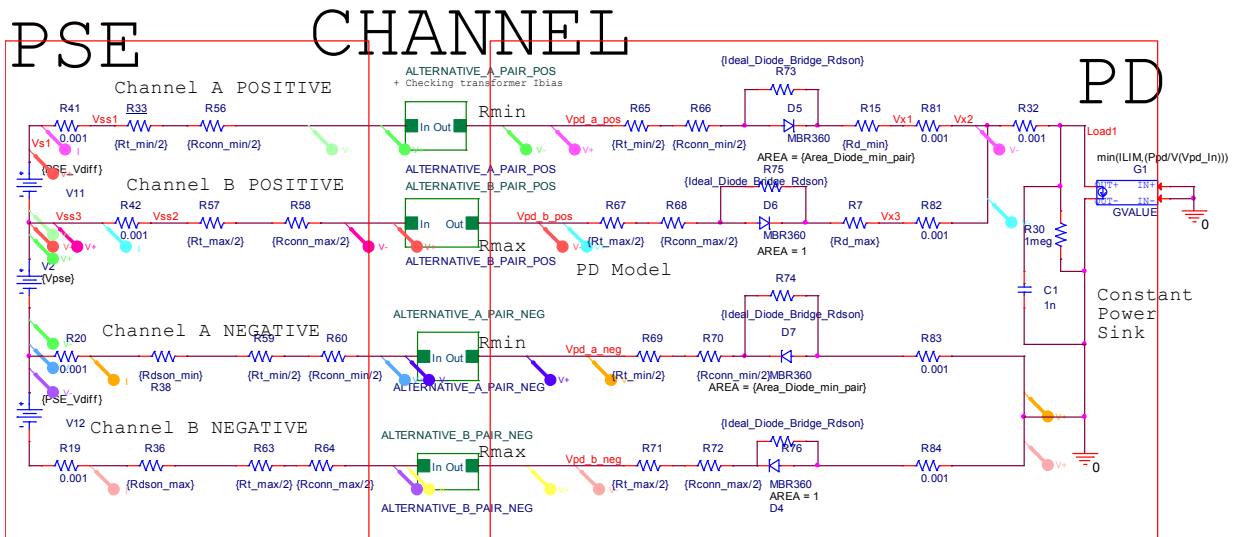

1

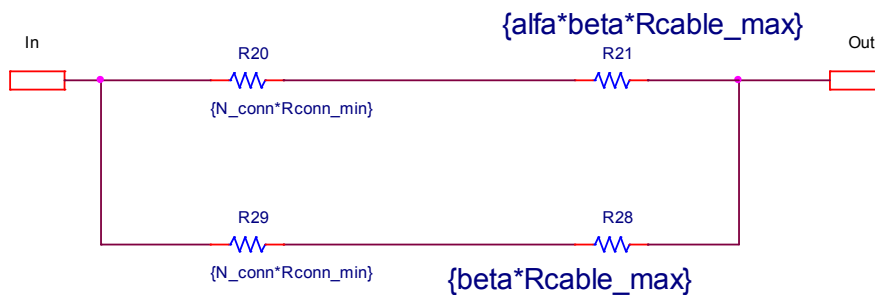

2

3

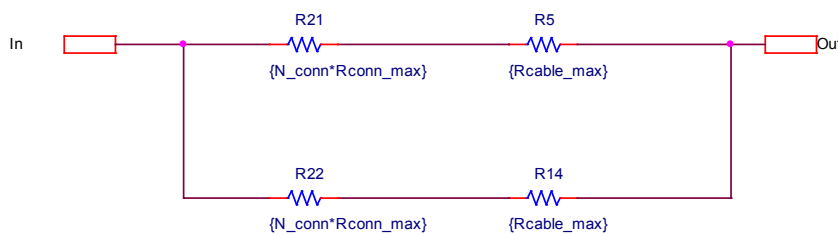

4

5 Simulation results on the positive pairs Done for IEEE802.3bt D2.2 and D2.3 for
6 reference.

7

Cable Length (m)	2.65m	100m	Spec in D2.2	Notes
Channel max common mode resistance resistance (Ω)	0.2	12.5		It is the value of two conductors in parallel from PSE PI to PD PI and back.
Number of connectors	0	4		
PSE Vdiff (mV)	10	10		
PD Vdiff (mV)	60	60		
Pair with maximum current (mA) on I(R41)	I _{max} ,	I _{max} ,	I _{max} =I _{cont_2P_unb}	Positive pairs
Class 5	547.07	483.86	550(*)	Maximum current is at short cable length.
Class 6	678.65	638.83	682(*)	Maximum current is at short cable length.
Class 7	780.85	764.43	781(**)	Maximum current is at short cable length. Different from D2.1 results (maximum current was at long cable) due to different model parameters values that was updated at D2.1 meeting.
Class 8	911.62	911.61(*)	931(***)	Maximum current is at long cable length.

8

(*) Spec was not changed in D2.2 for class 5 and 6 in order to finish first the significant digits issues.

9

(**) (Spec was changed in D2.2 for class 7 to update per the updated sim results.

10

(**) Spec was changed in D2.2 for class 8 to allow PD margin for Extended Class 8 use case. D2.1 spec was 925mA.