

Comment

(TDL #162 from D2.1)

1. Some updates are required for D2.2 for moving some of the normative requirements in Annex B to the standard body into 33.2.8.5.1 as requested by TDL #162.
2. As a result from (1), Annex 33B was updated accordingly and became informative

In addition the following updates were made:

3. Completing the missing numbers for long cable case in Table 33-1 due to the changes made to satisfy comment #162 from D2.1.
4. Additional updates due to moving from 71W to 71.3W, updating channel model at 100m per the changes made in D2.1 (striking the note in 33A.4)
5. Some text clarifications.

Suggested Remedy:

Baseline starts here

Modify the text per the proposed baseline:

This is not part of the base line

The following is a proposal to move some of the important shall's from Annex B to to 33.2.8.5.1 as required by the TDL above.

33.2.8.5.1 PSE PI pair-to-pair effective resistance and current unbalance

This section describes unbalance requirements for Type 3 and Type 4 PSEs that operate over 4-pair. The contribution of PSE PI pair-to-pair effective resistance unbalance to the ~~effective~~ system end to end effective resistance unbalance, is specified by PSE maximum (RPSE_max) and minimum (RPSE_min) common mode effective resistance in the powered pairs of same polarity. [See Figure 33B-1. Effective resistances of RPSE_min and RPSE_max include the effects of VPort_PSE_diff as specified in Table 33-18 and the PSE PI resistive elements. See definition and measurements in Annex 33B.](#)

The PSE PI pair-to-pair effective resistance unbalance determined by RPSE_max and RPSE_min ensures that along with any other parts of the system, i.e. channel (cables and connectors) and the PD, the maximum pair current including unbalance does not exceed ICon-2P-unb as defined in Table 33-18 during normal operating conditions. ICon-2P-unb is the current in the pairset with the highest current in [the](#) case of maximum unbalance and will be higher than ICon/2. ICon-2P-unb applies for total channel common mode pair resistance from 0.2 Ω to [Rchan-2P](#). ~~R_{ch}~~. [Rchan-2P](#) is specified in 33.1.3. For channels with common mode pair resistance [Rchan-2P](#) lower than 0.2 Ω or lower than RCH_max=0.1Ω (See Figure 33A-XX, Figure 33B-1 and Figure 33B-4), see [33.2.8.5.1.1. Annex 33B-1](#)

**Move Figure 33B-1 to 33.2.8.5.1 (to this location) with the marked updates.
Update Figure numbers as required.**

Figure 33B-1—PSE PI unbalance specification and E2EP2PUnb

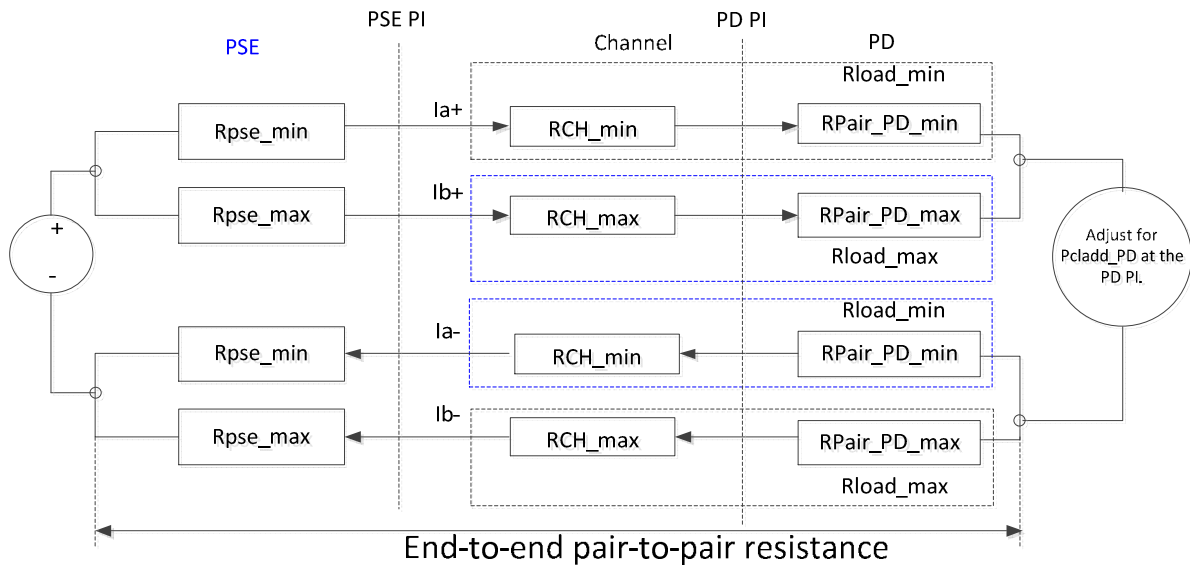

R_{Ch} is the maximum value of (RCH_min + RCH_max) as described in Figure 33-B1.

RCH_max is the sum of channel pair elements with highest common mode resistance and RCH_min is the sum of channel pair elements with lowest common mode resistance.

RPSE_max and RPSE_min min are specified and measured under maximum PClass sourcing conditions and V_{Port_PSE-2P} operating range. R_{PSE_min} need to be greater than $\{(-\beta/\alpha)\}_\Omega$ according to Equation 33-15 format of $RPSE_max \leq \alpha \times RPSE_min + \beta$ in order to satisfy Equation 33-15. Conformance with Equation (33-15) shall be met for RPSE_max and RPSE_min.

PSEs that support Class 6 and Class 8 per 33.3.8.2.1 conditions shall meet Equation 33-15a.

To updates constants in Equation 33-15 as follows:

To change in Equation 33-15 from “RPSE_max=” to “RPSE_max ≤”

Add Equation 33-15a and append it to Equation 33-15 for supporting Extended power.

$$R_{PSE_max} \leq \begin{cases} 2.170 \times R_{PSE_min} - 0.040 & \text{for Class 5} \\ 1.988 \times R_{PSE_min} - 0.040 & \text{for Class 6} \\ 1.784 \times R_{PSE_min} - 0.030 & \text{for Class 7} \\ 1.727 \times R_{PSE_min} - 0.030 & \text{for Class 8} \end{cases} \quad 33-15$$

$$R_{PSE_max} \leq \begin{cases} 1.309 \times R_{PSE_min} + 0.011 & \text{for Class 6 per 33.3.8.2.1} \\ 1.166 \times R_{PSE_min} + 0.015 & \text{for Class 8 per 33.3.8.2.1} \end{cases} \quad 33-15a$$

where

RPSE_max is, given RPSE_min, the highest allowable common mode effective resistance in the powered pairs of the same polarity.

RPSE_min is the lower PSE common mode effective resistance in the powered pairs of the same polarity.

Common mode resistance is the resistance of the two wires and their elements in a pair of the same polarity connected in parallel.

The values of RPSE_max as function of RPSE_min where derived from the system end to end pair to pair effective resistance 4-pairs model and accounts for channel pair to pair unbalance and PD PI pair to pair unbalance at worst case unbalance conditions.

The values of RPSE_max and RPSE_min are implementation specific and need to satisfy Equation (33–15). RPSE_max, RPSE_min and ICon-2P-unb shall be ~~measured~~ determined according to ~~with~~ the tests model specified in 33.2.8.5.1.1. See Annex 33B for additional information ~~described in the normative Annex 33B.~~

Move the following text from Annex B to 33.2.8.5.1.1 with the following updates. Update Tables and Figure numbers accordingly.

33.2.8.5.1.1 ~~33B-4~~ Current unbalance measurement

The following method ~~may~~ shall be used to verify RPSE_min and R_{PSE_max} meet Equation 33-15 if the internal PSE circuits are not accessible or if the PSE is using active or passive current balancing circuitry that results in a variable effective resistance to control current unbalance. The current unbalance requirement shall be met for any pairs of the same polarity and with the load resistances per Table 33B–1. A PSE which uses current balancing methods which effectively using lower R_{PSE_max} than required by Equation 33-15 and meets ICon-2P_unb requirements, by definition also meets Equation (33–15). Figure 33B–4 shows a test circuit for the current unbalance requirements measurement.

Other methods for measuring RPSE_min and RPSE_max are described in Annex B.

ICon_2P_unb max and Equation 33-15 are specified for total channel common mode pair resistance R_{chan-2P} from 0.2Ω to 12.5Ω and worst case unbalance contribution by a PD as specified by 33A.5. When the PSE is tested for channel common mode resistance less than 0.2 Ω, i.e. 0 Ω < R_{chan-2P} < 0.2 Ω, the PSE shall be tested with (R_{load_min} – 0.5xR_{chan-2P}) and (R_{load_max} – 0.5xR_{chan-2P}) to meet ICon_2P_unb requirements and using lower RPSE_max than required by Equation (33–15).

Lower RPSE_max than required by Equation (33–15) is obtained by using smaller constants α and larger constant β in the equation ~~R_{PSE_max} = α × R_{PSE_min} + β~~ R_{PSE_max} = α × RPSE_min - β (See Equation 33-15).

Move Figure 33B-4 to this location with the following marked updates.

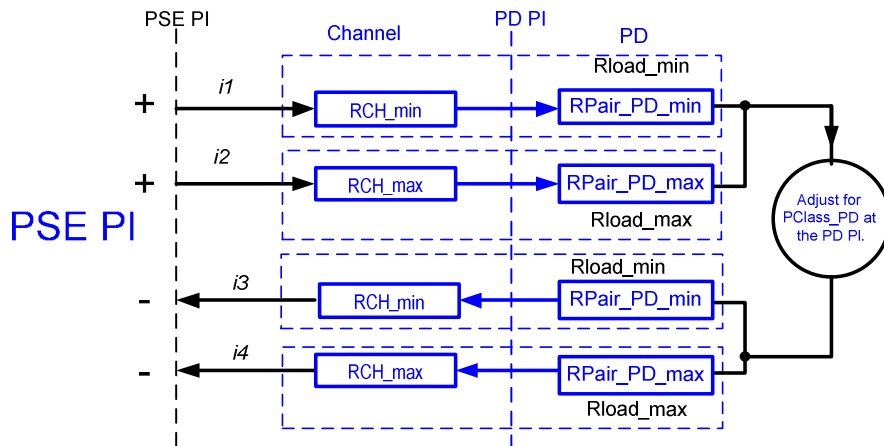

Figure 33B-4—Current unbalance test circuit

The current unbalance test circuit is shown in Figure 33B-4. The test method is described below:

- 1) Use Rload_min and Rload_max from Table 33B-1 for Rload at low channel resistance conditions.
- 2) With the PSE powered on, adjust the load to Pclass_PD.
- 3) Measure I1, I2, I3 and I4.

4) Swap Rload_max, Rload_min, repeat steps 1 and 2.

5) Repeat for I3, I4.

6) Verify that the current in any pair each case does not exceed Icon-2P_unb minimum in Table 33-18.

7) Repeat steps 1-6 for Rload_min and Rload_max from Table 33B-1 for Rload at high channel resistance conditions.

1. Move Table 33B-1 from Annex B to this location with the following updated.
2. Add to Yair TDL to specify value tolerance and final significant digits since Table 33B-1 values are actual resistors in the test model. The objective is to set Icon-2P_unb accuracy to +/-5mATBD.

Table 33B-1—Rload_max and Rload_min requirements

PSE Class	RCH_min, [Ω]	RCH_max, [Ω]	RPair_PD_min, [Ω]	RPair_PD_max, [Ω]	Rload_min, [Ω]	Rload_max, [Ω]	Additional Information
5	0.087 0.089	0.1 0.101	0.641 0.636	1.518 1.528	0.730 0.723	1.619 1.628	Rload is at low channel resistance conditions. All resistances with ±1% accuracy.
6			0.541 0.536	1.183 1.189	0.630 0.623	1.283 1.289	
7			0.485 0.503	1.016 0.99	0.575 0.59	1.117 1.09	
8			0.442 0.457	0.892 0.875	0.531 0.544	0.993 0.975	
6 per 33.3.8.1			0.646	0.851	0.735	0.951	
8 per 33.3.8.1			0.540	0.618	0.629	0.718	
5	5.513	6.250	0.711	1.021	6.224 5.92	7.271 7.19	Rload is at high channel resistance conditions. All resistances with ±1% accuracy.
6			0.569	0.817	6.082 5.78	7.067 7	
7			0.495	0.712	6.008 5.71	6.962 6.87	
8			0.433	0.625	5.946 5.65	6.875 6.79	
6 per 33.3.8.1			0.683	0.811	6.196	7.061	
8 per 33.3.8.1			0.552	0.620	6.065	6.870	

Table 33B-1 specify the values of Rload_min and Rload_max components according to Equations 33-15B and Equation 33-15C.

$$Rload_min = RPair_PD_min + RCH_min \quad (33-15B)$$

$$Rload_max = RPair_PD_max + RCH_mx \quad (33-15C)$$

Where

Rload_min is the minimum common mode effective load resistance in the powered pairs of the same polarity. Rload_min is composed from the minimal common mode channel resistance RCH_min and the minimum common mode effective PD PI resistance PD Rpair_PD_min.

Rload_max is the maximum common mode effective load resistance in the powered pairs of the same polarity. Rload_max is composed from the maximum common mode channel resistance RCH_max and the maximum common mode effective PD PI resistance Rpair_PD_max

RPair_PD_min is the minimum common mode effective PD PI resistance that accounts for the effective resistance of resistive elements combined with PD pair to pair voltage difference and the effect of system end to end pair to pair resistance unbalance. See 33A-5.

$R_{\text{Pair_PD_max}}$ is the maximum common mode effective PD PI resistance that accounts for the effective resistance of resistive elements combined with PD pair to pair voltage difference and the effect of system end to end pair to pair resistance unbalance. See 33A-5.

$R_{\text{CH_min}}$ is the minimum common mode channel resistance in the powered pairs of the same polarity from PSE PI to PD PI. See 33A-4.

$R_{\text{CH_max}}$ is the maximum common mode channel resistance in the powered pairs of the same polarity from PSE PI to PD PI. See 33A-4.

33.3.8.10 PD pair-to-pair current unbalance

Make the following changes for 33.3.8.10

This is not part of the base line

-In previous drafts we have used average ratio of $R_{\text{source_max}}/R_{\text{source_min}}=1.186$ for both short cable case and long cable case. The following changes were made after founding that using constant ratio between $R_{\text{source_max}}$ and $R_{\text{source_min}}$ is not sufficient due to 15% differences between the ratio required for the short cable and the ratio required for the long cable.

Under all operating states, single-signature PDs assigned to Class 5 or higher shall not exceed ICon-2P- unb for longer than TCUT-2P min as defined in Table 33–18 on any pair when PD PI pairs of the same polarity are connected to all possible common source voltages in the range of VPort_PSE-2P through two common mode resistances, $R_{\text{source_min}}$ and $R_{\text{source_max}}$, where ~~$R_{\text{source_max}} = 1.186 * R_{\text{source_min}}$~~ $R_{\text{source_max}} = (-0.031 * R_{\text{source_min}} + 1.309) * R_{\text{source_min}}$, and $R_{\text{source_min}}$ are all possible resistances in the range of ~~$0.1680.147 \Omega$~~ to ~~$5.28-5.568 \Omega$~~ as shown in Figure 33–37.

Under all operating states, dual-signature PDs shall not exceed ICon-2P as defined in Equation (33–8) for longer than TCUT-2P min as defined in Table 33–18 on any pair when PD PI pairs of the same polarity are connected to all possible common source voltage in the range of VPort_PSE-2P through two common mode resistances, $R_{\text{source_min}}$ and $R_{\text{source_max}}$, where ~~$R_{\text{source_max}} = 1.186 * R_{\text{source_min}}$~~ $R_{\text{source_max}} = (-0.031 * R_{\text{source_min}} + 1.309) * R_{\text{source_min}}$, and $R_{\text{source_min}}$ are all possible resistances in the range of ~~$0.1680.147 \Omega$~~ to ~~$5.28-5.568 \Omega$~~ as shown in Figure 33–37.

$R_{\text{source_min}}$ and $R_{\text{source_max}}$ represent the V_{in} source common mode effective resistance that consists of the PSE PI components ($R_{\text{PSE_min}}$ and $R_{\text{PSE_max}}$ as specified in 33.2.8.5.1, VPort_PSE_diff as specified in Table 33–18, the channel resistance, and influence of $R_{\text{PAIR_PD_min}}$, $R_{\text{PAIR_PD_max}}$ specified in 33A.5 as function of system end-to-end unbalance). Common mode effective resistance is the resistance of two conductors of the same pair and their other components, which form R_{source} , connected in parallel including the effect of the system (PSE and PD) total pair to pair voltage difference. I_A and I_B are the pair currents of pairs with the same polarity. PD PI contribution to system end to end pair to pair effective eresistance unbalance is specified by $R_{\text{PAIR_PD_min}}$, $R_{\text{PAIR_PD_max}}$ as defined in 33A.5. $R_{\text{PAIR_PD_min}}$, $R_{\text{PAIR_PD_max}}$ represents the effective common mode resistance of pairs with the same polarity that accounts for the PD PI resistive elements and PD pair to pair voltage difference.

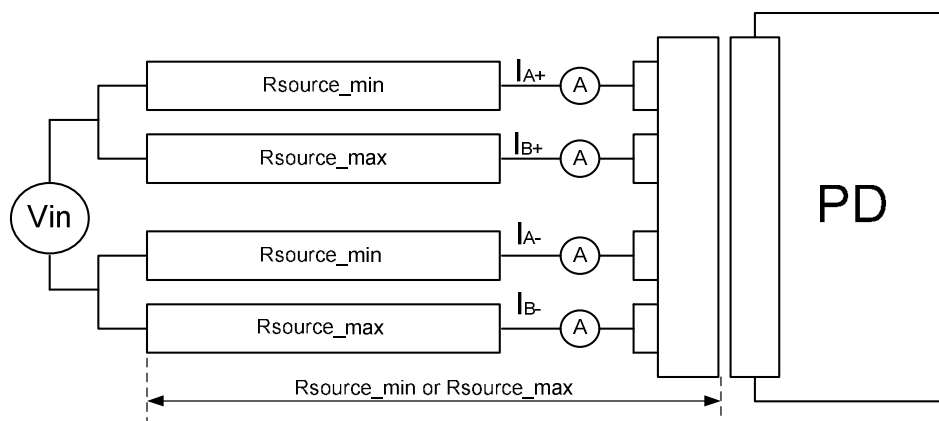

Figure 33–39—Icon-2P and Icon-2P-unb evaluation model

NOTE 1—Rsource includes resistance Rcon which is the connection resistance at the PD. The maximum recommended Rcon value is 0.02 Ω.

NOTE 2—The pairset current limits should also be met when Rsource_max and Rsource_min are swapped between pairs of the same polarity.

33A.3 Intra pair resistance unbalance

Make the following changes:

Operation for all PSE and PD Types requires that the resistance unbalance be 3% or less. Resistance unbalance is a measure of the difference between the two conductors of a twisted pair in the 100 Ω balanced cabling system.

Resistance unbalance is defined as in Equation (33A–1):

$$\left\{ \frac{(R_{\max} - R_{\min})}{(R_{\max} + R_{\min})} \times 100 \right\} \% \quad (33A-1)$$

where

R_{\max} is the resistance of the pair conductor with the highest resistance

R_{\min} is the resistance of the pair conductor with the lowest resistance. ~~Common mode resistance is the resistance of the two wires in a pair (including connectors), connected in parallel.~~

Common mode resistance is the resistance of the two wires in a pair (including connectors), connected in parallel.

33A.4 Pair-to-pair channel resistance unbalance requirement for 4-pair operation

Make the following changes:

Operation using 4-pair requires the specification of resistance unbalance between each two pairs of the channel, not greater than 100 milliohm or resistance unbalance of 7% whichever is a greater unbalance. Resistance unbalance between the channel pairs is a measure of the difference of resistance of the common mode pairs of conductors used for power delivery. Channel pair-to-pair resistance unbalance is defined by Equation (33A-2). [The resistance of the common mode pairs of conductors and connectors RCH_min and RCH_max are described by Figure 33A-XX.](#)

Not part of the baseline
 Figure 33A-XX was added to differentiate between R_{ch} term used from PSE PI to PD PI and back and the channel resistance of pair of wires and their connectors from PSE PI to PD PI (one way) that is used in this Annex and all related P2Punb clauses.

Add Figure 33A-XX

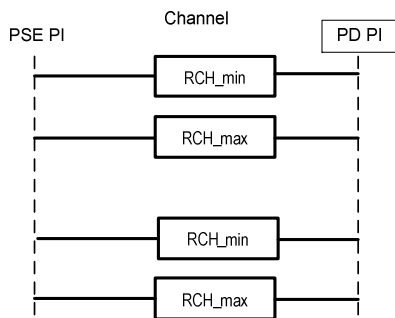

Figure 33A-XX – Common mode Pair-to-pair channel resistance unbalance

Replace Rch_max and Rch_min with RCH_min and RCH_max as follows.

$$\left\{ \frac{(RCH_max - RCH_min)}{(RCH_max + RCH_min)} \times 100 \right\} \% \quad (33A-2)$$

Channel pair-to-pair resistance difference is defined by Equation (33A-3):

$$\{RCH_max - RCH_min\} \quad (33A-3)$$

where

~~Rch_max~~ RCH_max is the sum of channel pair elements with highest common mode resistance
~~Rch_min~~ RCH_min is the sum of channel pair elements with lowest common mode [resistance](#).
[resistance](#) Common mode resistance is the resistance of the two wires in a pair (including connectors), connected in parallel.

[Common mode resistance is the resistance of the two wires in a pair \(including connectors\), connected in parallel.](#)

33A.5 PD PI pair-to-pair current unbalance requirements

-Update equation 33A-4 constants as follows (Updates are due to: Changing 71W to 71.3W, final updates of PD Vdiff to 60mV for Type 3 and Type 4, channel P2PRun changes made for D2.2)

- Update equation 33A-4 from “Rpair_pd_max=” to “Rpair_pd_max≤”
- Add Equation 33A-4a to support Extended power
- To append Equation 33A-4a to 33A-4.

The following design guide lines may be implemented to ensure PD PI pair-to-pair current unbalance requirements are met:

$$R_{Pair_PD_max} = \left. \begin{cases} 2.170 \times R_{Pair_PD_min} + 0.125 & \text{for PD Type 3, Class 5} \\ 1.988 \times R_{Pair_PD_min} + 0.105 & \text{for PD Type 3, Class 6} \\ 1.784 \times R_{Pair_PD_min} + 0.080 & \text{for PD Type 4, Class 7} \\ 1.727 \times R_{Pair_PD_min} + 0.074 & \text{for PD Type 4, Class 8} \end{cases} \right\} \Omega \quad (33A-4)$$

$$R_{Pair_PD_max} = \left. \begin{cases} 1.309 \times R_{Pair_PD_min} + 0.005 & \text{for PD Type 3, Class 5 per 33.3.8.2.1} \\ 1.166 \times R_{Pair_PD_min} + 0.005 & \text{for PD Type 3, Class 6 per 33.3.8.2.1} \end{cases} \right\} \Omega \quad (33A-4a)$$

~~Smaller constants α and β in the equation $R_{Pair_PD_max} = \alpha \times R_{Pair_PD_min} + \beta$ ensure that $I_{Con-2P-ub}$ is not exceeded for PD power consumption above the values in Table 33-26.~~

RPair_PD_min need to be greater than $\{(-\beta/\alpha)\}_\Omega$ according to Equation 33A-4 format of $R_{Pair_PD_max} \leq \alpha \times R_{Pair_PD_min} + \beta$ in order to satisfy Equation 33-A4.

RPair_PD_max and RPair_PD_min represent PD common mode input effective resistance of pairs of the same polarity. Common mode effective resistance is the resistance of two conductors of the same pair and their other components connected in parallel including the effect of PD pair-to-pair voltage difference of pairs with the same polarity (e.g. Vf1-Vf3). The common mode effective resistance Rn is the measured voltage Veff_pd_n, divided by the current through the path as described below and as shown in the example in Figure 33A-4, where n is the pair number.

This is not part of the baseline

We can simplify text and drawing by deleting R1, R2, R3 and R4 from the text and Figure 33A-4 since we have we have Rpair_PD_min/max definitions already in the drawing and the text.

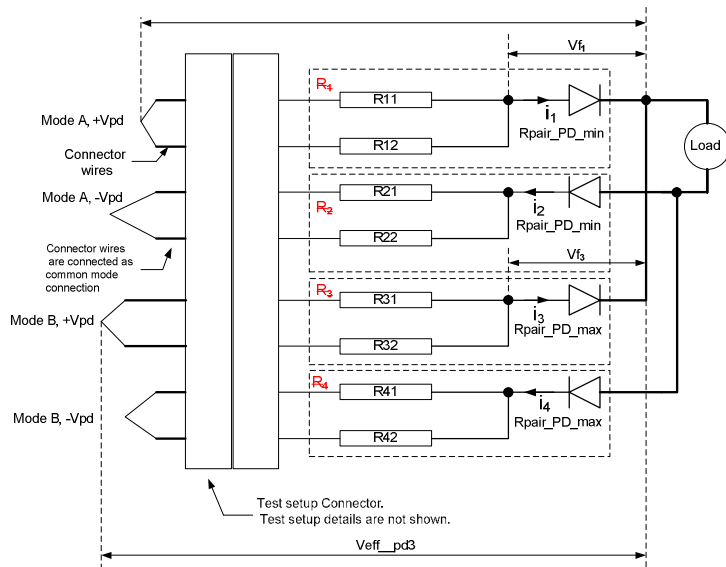

Figure 33A-4—PD resistance unbalance elements overview

Positive pairs:

$$R_1 = R_{\text{Pair_PD_min}} = V_{\text{eff_pd1}} / i_1$$

$$R_3 = R_{\text{Pair_PD_max}} = V_{\text{eff_pd3}} / i_3$$

Negative pairs:

$$R_2 = R_{\text{Pair_PD_min}} = V_{\text{eff_pd2}} / i_2$$

$$R_4 = R_{\text{Pair_PD_max}} = V_{\text{eff_pd4}} / i_4$$

Annex 33B

This is not part of the baseline

The important shalls moved from Annex B to PSE PI unbalance section in 33.2.8.5.1 and 33.2.8.5.1.1 and Annex 33B was updated accordingly.

(~~normative~~[Informative](#)) *Insert Annex 33B after Annex 33A as follows:*

PSE PI pair-to-pair resistance/current unbalance

33B.1 Introduction

End to end pair-to-pair resistance/current unbalance (E2EP2P_{unb}) refers to current differences in powered pairs of the same polarity. Current unbalance can occur in positive and negative powered pairs when a PSE uses all four pairs to deliver power to a PD.

Current unbalance requirements (RPSE_{min}, RPSE_{max} and Icon-2P_{unb}) of a PSE ~~shall be~~[is](#) met with Rload_{max} and Rload_{min} as specified ~~by~~[in](#) Table 33B-1.

A compliant unbalanced load, Rload_{min} and Rload_{max} consists of the channel (cables and connectors), and PD effective resistances, including the effects (*or influence*) of PSE PI effective resistance as a function of the system end-to-end unbalance.

This is not part of the baseline

The following part was moved to 33.2.8.5.1

~~Icon-2P_{unb} max and Equation 33-15 are specified for total channel common mode pair resistance R_{Ch-2P} from 0.2Ω to 12.5Ω and worst case unbalance contribution by a PD as specified by 33A.5. When the PSE is tested for channel common mode resistance less than 0.2 Ω, i.e. 0 Ω < R_{chan-2P} < 0.2 Ω, the PSE shall be tested with (Rload_{min} - 0.5xR_{chan-2P}) and (Rload_{max} - 0.5xR_{chan-2P}) to meet Icon-2P_{unb} requirements and using lower R_{pse_max} than required by Equation (33-15).~~

~~Lower R_{pse_max} than required by Equation (33-15) is obtained by using smaller constants α and larger constant β in the equation R_{pse_max} = α × R_{pse_min} + β.~~

Equation (33-15) is described in 33.2.8.5.1, specified for the PSE, assures that E2EP2P_{unb} will be met in the presence of all compliant, unbalanced loads (Rload_{min} and Rload_{max}) attached to the PSE PI.

Figure 33B-1 illustrates the relationship between effective resistances at the PSE PI as specified by Equation (33-15) and Rload_{min} and Rload_{max} as specified in Table 33B-1.

There are ~~three~~[two](#) alternate test methods for RPSE_{max} and RPSE_{min} and determining conformance to Equation (33-15) and to Icon-2P_{unb}.

Measurement methods to determine RPSE_{max} and RPSE_{min} and Icon-2P_{unb} are defined in 33B.1,[and](#) 33B.2,~~and 33B.3.~~

Delete Figure 33B-1. It was moved and updated to 33.2.8.5.1

Delete Table 33B-1. It was moved and updated in 33.2.8.5.1

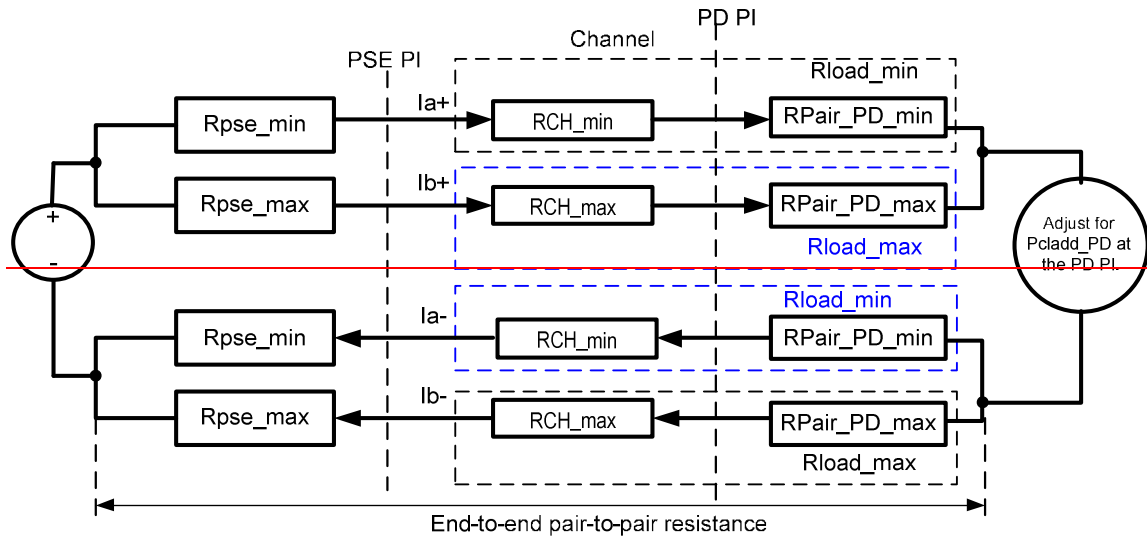

Figure 33B-1—PSE PI unbalance specification and E2EP2PRunb

Table 33B-1—Rload_max and Rload_min requirements

PSE Class	RCH_min, [Ω]	RCH_max, [Ω]	RPair_PD_min, [Ω]	RPair_PD_max, [Ω]	Rload_min, [Ω]	Rload_max, [Ω]	Additional Information
5	0.087	0.1	0.636	1.528	0.723	1.628	Rload is at low channel resistance conditions
6	0.087	0.1	0.536	1.189	0.623	1.289	
7	0.087	0.1	0.503	0.99	0.59	1.09	
8	0.087	0.1	0.457	0.875	0.544	0.975	
5					5.92	7.19	Rload is at high channel resistance conditions
6					5.78	7	
7					5.71	6.87	
8					5.65	6.79	

33B.2 Direct RPSE measurement

If there is access to internal circuits, effective resistance may be determined by sourcing current in each path corresponding to maximum PClass operation, and measuring the voltage across all components that contribute to the effective resistance, including circuit board traces and all components passing current to the PSE PI output connection. The effective resistance is the measured voltage V_{eff} , divided by the current through the path e.g. the effective value of $RPSE_{min}$ for $i1$ is $RPSE_{min} = V_{eff}/i1$ as shown in Figure33B-2.

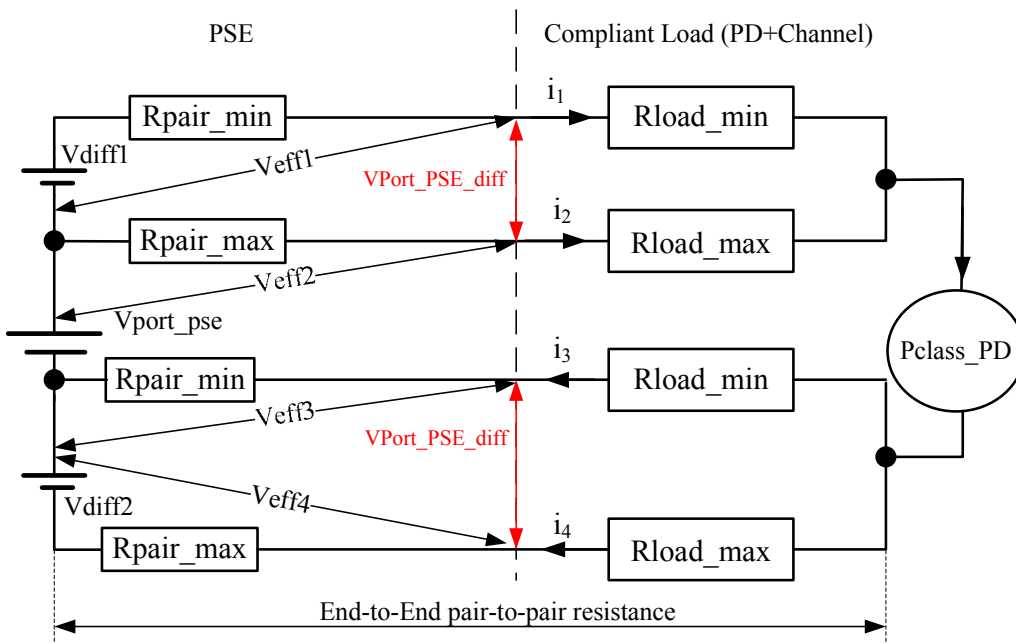

Figure 33B-2—Direct measurements of effective R_{PSE_max} and R_{PSE_min}

33B.3 Effective resistance R_{PSE} measurement

Add to TDL: Ken to verify that the following test model works in simulations

Figure 33B-3 shows a possible test circuit for effective resistance measurements on a PSE port for evaluating conformance to Equation (33-15) if the internal circuits are not accessible. In Figure 33B-3, the positive pairs of the same polarity are shown as an example. The same concept applies to the negative pairs.

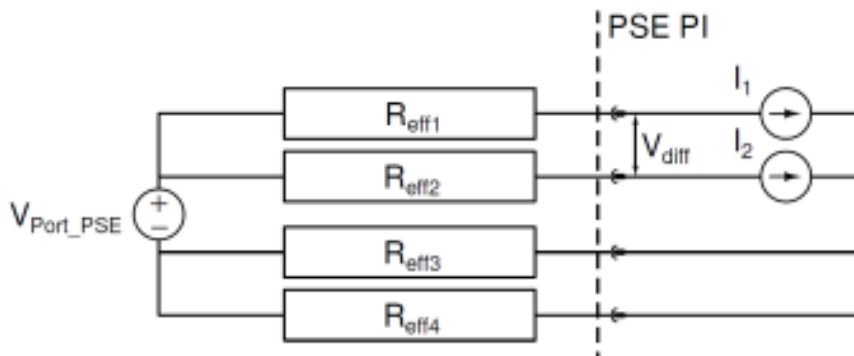

Figure 33B-3 – Effective resistance test circuit

The Effective Resistance Test Procedure is described below:

- 1) With the PSE powered on, set the following current values
 - a. $10 \text{ mA} < I_2 < 50 \text{ mA}$
 - b. $I_1 = 0.5 \times (P_{max}/V_{port}) - I_2$
- 2) Measure V_{diff} .
- 3) Reduce I_1 by 20% ($=I_1'$). Ensure I_2 remains unchanged.
- 4) Measure V_{diff}' in the same manner as V_{diff} .

- 5) Calculate R_{eff1} : $R_{eff1} = [(V_{diff}) - (V_{diff}')] / (I_1 - I_1')$
- 7) Repeat procedure for R_{eff2} , with I_1 , I_2 values swapped.
- 8) Repeat procedure for R_{eff3} , R_{eff4} .
- 9) Evaluate compliance of R_{eff1} and R_{eff2} with Equation (33–15). Evaluate compliance of R_{eff3} and R_{eff4} with Equation (33–15).

The effective resistance test method applies to the general case. If pair-to-pair balance is actively controlled in a manner that changes effective resistance to achieve balance, then the current unbalance measurement method described in 33B.4 shall be used.

33B.4 was moved to 33.2.8.5.1 per the TDL

Update the PICS in: **33B.5 Protocol implementation conformance statement (PICS) proforma for Annex 33B PSE PI pair-to-pair resistance/current unbalance1**

END OF BASELINE

Annex A – 4-pairs spice simulation model parameters used to specify IEEE802.3bt D2.2 requirements.

The following values of the 4-pair model where used to set the specification requirements of the PSE PI and the PD PI unbalance requirements as a function of the total system end to end pair to pair effective resistance/current unbalance.

#	Parameter	Units	Class 5-6		Class 7-8		Notes
			Min	Max	Min	Max	
1	Vpse	Vdc	50.31	----	52.31	----	PSE voltage source, no load voltage
2	Ppd	W	40, 51	----		----	PD input power measured at the PD PI
3	Ppd extended power	W	59.7	----	89.4	----	PD input power measured at the PD PI
4	Lcable	m	2.65	100	2.65	100	Cable and cordage length.
5	Diode AREA2	-	10		10		Diode simulation parameter. Set the PD Vdiff compare to the diode in the pair with minimum resistance that is set to AREA=1. As a result, PD Vdiff is set to $V_{diff}=(n*K*T/q)*LN(I_{s2}/I_{s1})$ while $I_{s2}=I_{s1}$ (same diodes only AREA parameter is changed) . As a result, AREA2/AREA1 sets PD Vdiff. For AREA2=10 we will get PD Vdiff =60mV measured at IF=10mA (PD Vdiff is the pair to pair PD voltage difference casued by the forward voltage difference between two diodes on pairs of the same polarity. PD Vdiff is determined at low current (few mA range). When current increase the effect of PD Vdiff on the PD contribution to its PI unbalance and to the total system unbalance is reduced. The use of diodes with higher Vdiff, will increase the PD unbalance at high currents. Therefore a limit of 60mV for PD Vdiff was set at 10mA.
	Diode AREA1	-	1	----	1		Diode simulation parameter set to AREA 1. This diode is located at the pair with maximum resistance.
	Cordage Resistivity	Ω/m	0.0926	----	0.0926	----	Used for short channel length with Lacble =2.65m simulations
	Cable resistivity	Ω/m	0.074	----	0.074	----	Used for short channel length with Lacble =2.65m simulations
	Nuber of connectors	-	0	----	0	----	Used for short channel length with Lacble =2.65m simulations
	Cordage Resistivity	Ω/m	0.123	Ω	0.123	----	Used for long channel length with Lacble =100m simulations
	Cable resistivity	Ω/m	0.123	Ω	0.123	----	Used for long channel length with Lacble =100m simulations
	Nuber of connectors	-	4	----	4	----	Used for long channel length with Lacble =100m simulations
	Minimum Channel Resistance wire 1	Ω	$=\alpha*\beta*L_{cable}*(0.1*cordage_resistivity+0.9*cable_resistivity)+N*R_{conn_min}$				1 st wire of the pair with minimum resistance $\alpha=(1-pair_Runb)/(1+pair_Runb)=0.96$. Pair_Runb=0.02. $B=(1-pair2p_Runb)/(1+pair2p_Runb)=0.9$. Pair2p_Runb=0.05. Wire length is measured from PSE PI to PD PI (not round loop). Each pair of the same polarity has two wires (wire 1 and wire 2) are connected in parallel and form common mode resistance of that pair. In the positive pairs, we have two pairs with the same voltage polarity, the 1 st pair is set to minum resistance and the 2 nd pair is set to maximum resistance. The same applies to the negative pairs.
	Minimum Channel Resistance wire 2	Ω	$=\beta*L_{cable}*(0.1*cordage_resistivity+0.9*cable_resistivity)+N*R_{conn_min}$				
	Maximum Channel Resistance wire 1 and wire 2		$L_{cable}*(0.1*cordage_resistivity+0.9*cable_resistivity)$				
	PSE Vdiff	mV	10	----	10	----	
	Rt	Ω	0.12	0.13	0.12	0.13	Transformer winding resistance
	Rconn	Ω	0.03	0.05	0.03	0.05	Connector resistance
	Rdson	Ω	0.07	0.1	0.07	0.1	
	Rsense	Ω	0.0225	0.25	0.0225	0.25	

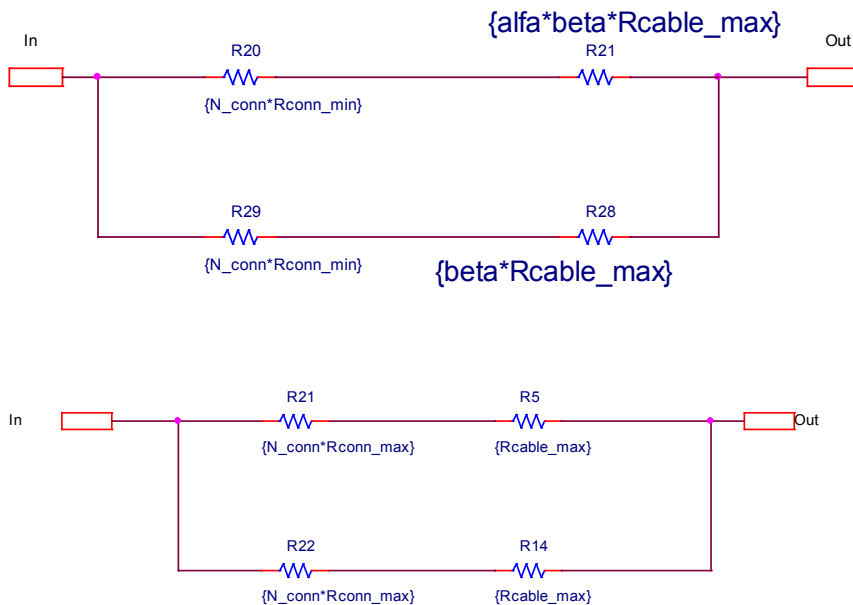
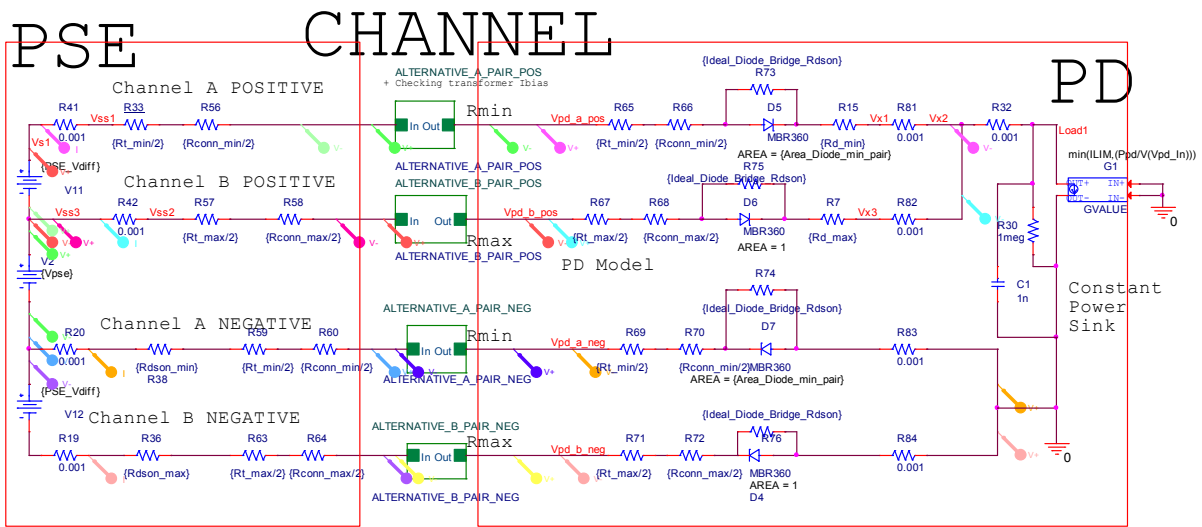

Simulation results on the positive pairs Done for IEEE802.3bt D2.2 for reference.

Cable Length (m)	2.65m	100m	Spec in D2.2	Notes
Cable max wire resistance (Ω)	0.2	12.5		
Number of connectors	0	4		
PD Vdiff (mV)	60	60		
Pair with maximum current (mA) on I(R41)	I _{max} ,	I _{max} ,	I _{max} =I _{cont_2P_u} nb	Positive pairs
Class 5	546.16	479.79	550	Maximum current is at short cable length.
Class 6	677.42	634.46	682	Maximum current is at short cable length.
Class 7	779.39	759.53	777	Maximum current is at short cable length. Different from D2.1 results (maximum current was at long cable) due to different model parameters values that was updated at D2.1 meeting.
Class 8	884.3	906.47(*)	925	Maximum current is at long cable length.

(**)Spec was not changed in D2.2 for class 5,6, and 7 in order to finish first the significant digits issues.

(*)Spec was not changed in D2.2 for class 8 to allow margin for Extended Class 8 use case (Keep using 925mA).

Annex B – Calculating RPSE_min from Equation 33-15

RPSE_max is a function of RPSE_min according to Equation 33-15 structure $RPSE_{max} = \alpha \cdot RPSE_{min} + \beta$.

In addition we need to ensure $RPSE_{max} > RPSE_{min}$.

$$R_{PSE_max} \leq \alpha \cdot RPSE_min + \beta \quad \text{Equation 33-15 in IEEE802.3bt D2.2}$$

Additional requirements:

$$R_{PSE_max} > RPSE_min \quad \text{Equation 1}$$

$$R_{PSE_max} > 0 \quad \text{Equation 2}$$

If we keep $\alpha \cdot R_{PSE_min} + \beta > 0$, we also meet Equation 1 and 2.

$$\alpha \cdot R_{PSE_min} + \beta > 0$$

$$R_{PSE_min} > \frac{-\beta}{\alpha} \quad \text{Equation 3}$$