

Comment (#57, #58):
(TDL #513 D2.0).

The following updates to the unbalance requirements are based on the technical principles, 4-pair model and its component values presented Annex D that was used to derive all pair-to-pair unbalance requirements in 802.3bt.

1. To verify the accuracy of Equation 33-15 in short cable and $R_{pse_min}=0.1\Omega$
2. To add design flexibility in Equation 33-15 to address short cable at $V_{pse-2P_min}>50V, 52V$. (will be done for next meeting if still will be required by the group)

Analysis for the following conditions per the 4-pairs model and its data base¹:

- Short cable (per the 4-pairs model it is channel with 2.65m long and zero connectors which generate $R_{CH_max} \approx 0.1\Omega$).
- PSE contribution to system unbalance for class 6. R_{pse_max} per Equation 33-15 and $R_{pse_min} = 0.1\Omega$
- R_{load_max} and R_{load_min} (33B-1, Table 33B-1 and Figure 33B-1) for class 6.

Results:

- In simulation, we get accurate results for I_{con-2P_unb} that meets the spec.
- When using single calculation iteration of I_{con-2P_unb} : I_{con-2P_unb} is deviates by +9mA (error=1.31%).
- When using two calculation iterations by subtracting R_{load_min} and R_{load_max} power loss from Ppd, error is reduced and we meet the spec.
- When using two calculation iterations by when breaking R_{load} to R_{ch} and R_{pair_PD} and subtracting R_{pair_PD} loss from Ppd, error is reduced and we meet the spec which prove the point above that for short cable there is need to break the model from 2 parts to 3 parts.
 - The reason for why without breaking R_{load} to R_{ch} and R_{pair_PD} we get the same good results is that at short cable R_{ch} is negligible compare to R_{pair_PD} which is part of the PD.

Conclusions:

1. There is no need to calculated $I_{con_2P_unb}$ to meet the spec. The designer need to meet Equation 33-15 only.
2. Equation 33-15 is correct and accurate. No changes are needed.
3. In order to validate that the PSE vendor meets Equation 33-15, he should use Annex 33-B test models as indicated in the spec.
4. For the above use case in short cable, no need to change the model as currently specify in Annex B however it is recommended to do so due to the following:
 - a) It is clearer model that include all necessary information for the designer.
 - b) For long cables, we must break R_{load} to its R_{ch} and R_{pair_PD} components since in this case $R_{ch}>R_{pair_PD}$ which will result with significant error.

Suggested Remedy

1. Replace Figure 33B-1 with the following:

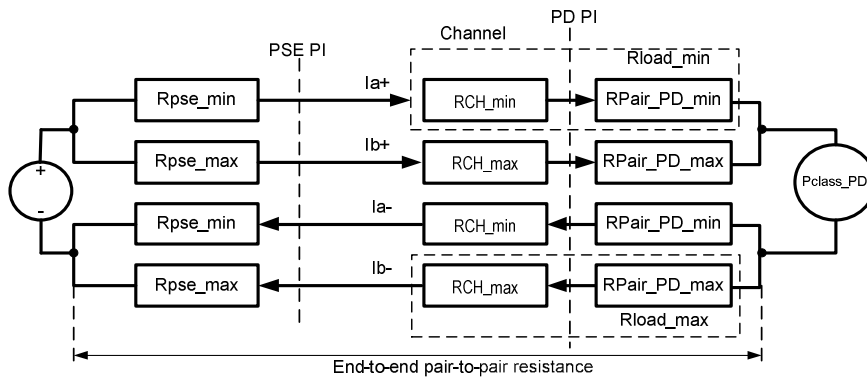

2. Replace Table 33B-1 with the following.

PSE Class	R_{CH_min} , [Ω]	R_{CH_max} , [Ω]	$R_{Pair_PD_min}$, [Ω]	$R_{Pair_PD_max}$, [Ω]	R_{load_min} , [Ω]	R_{load_max} , [Ω]	Additional Information
5	0.087	0.1	0.636	1.528	0.723	1.628	Rload is at low channel resistance conditions
6	0.087	0.1	0.536	1.189	0.623	1.289	
7	0.087	0.1	0.503	0.99	0.59	1.09	
8	0.087	0.1	0.457	0.875	0.544	0.975	
5	TBD	TBD	TBD	TBD	5.92	7.19	Rload is at high channel resistance conditions
6	TBD	TBD	TBD	TBD	5.78	7	
7	TBD	TBD	TBD	TBD	5.71	6.87	
8	TBD	TBD	TBD	TBD	5.65	6.79	

[Add to Yair's TDL: TBD will be replaced by numbers in next meeting.]

End of suggested Remedy

Annex A: Calculation without breaking Rload_min and Rload_max to Rch_min, Rch_max and Rpair_PD_min and Rpair_PD_max.

Implication: Due to the fact that:

Rpair_PD_min >> Rch_min and Rpair_PD_max >> Rch_max then the power loss on Rload_min and Rload_max is close Rpair_PD_min and Rch_min and Rpair_PD_max so we can subtract it from Ppd in order to have total Ppd including Rload power loss.

	Inputs		Equation
PSE PI min resistance	Rpse_min	0.1	
PSE output voltage at open load	Vpse	50.14	With correction due to voltage drop on Rpse
PD power of the constant power sink	Ppd	51	
Spec requirements	Icon_s	0.683	
PD input power at the PI including only Rpair_PD			
PD input power including Rload			
	Outputs		
PSE PI max resistance calculated per Eq 33-15	Rpse_max	0.161	$2.010 * Rpse_min - 0.04$
Rload min per Table 33B-1	Rload_min	0.623	Table 33B-1
Rload_max per Table 33B-1	Rload_max	1.289	Table 33B-2
Total pair min resistance from internal PSE source voltage to	Re2e1	0.723	$Rpse_min + Rload_min$
Total pair max resistance from internal PSE source voltage to	Re2e2	1.45	$Rpse_max + Rpse_max$
Total resistance of positive pairs of the same polarity	Re2eP	0.482	$Re2e1 Re2e2$
Mosfet RDSON	Rdson	0.05	(for the 2-pairs with the same polarity)
Rsense	Rsense	0.05	(for the 2-pairs with the same polarity)
Total resistance of negative pairs of the same polarity	Re2eN	0.582	$Re2eN = Re2eP + Rdson + Rsense$
Total system resistance from Vpse to Vpd and back	Re2e&B	1.0649	$Rtotal = Re2eP + Re2eN$
PD voltage at the constant power sink point	Vpd	49.0324	$Vpd = (Vpse + (Vpse^2 - 4 * Ppd * Rtotal)^{0.5}) / 2$
Total current over 4-pairs	Icon	1.0401	$Icon = (Vpse - Vpd) / Rtotal$
Ent to End Runb	E2ERunb	0.3346	$(Re2e2 - Re2e1) / (Re2e2 + Re2e1)$
The pair with the maximum current	I1	0.6921	$Icon * (1 - E2ERunb)$
The pair with the minimum current	I2	0.3563	$Icon * E2ERunb$
Deviation from the spec [A]		0.0091	$I1 - Icon_s$
Deviation from the spec		1.34%	$(I1 - Icon_s) / Icon_s$
Recalculating with substruting Rload_min and Rload_max power loss from Ppd			
Total power loss on Rpair_PD_min and Rpair_PD_max	P_Rpair_PD	0.890436	$I1 * Rpair_PD_min + I2 * Rpair_PD_max$
PD power of the constant power sink	Ppd_net	50.10956	
PD voltage at the constant power sink point	Vpd	49.0522	$Vpd = (Vpse + (Vpse^2 - 4 * Ppd_net * Rtotal)^{0.5}) / 2$
Total current over 4-pairs	Icon	1.0216	$Icon = (Vpse - Vpd) / Rtotal$
Ent to End Runb	E2ERunb	0.3346	$(Re2e2 - Re2e1) / (Re2e2 + Re2e1)$
The pair with the maximum current	I1	0.6798	$Icon * (1 - E2ERunb)$
The pair with the minimum current	I2	0.3418	$Icon * E2ERunb$
Deviation from the spec [A]		-0.0032	$I1 - Icon_s$
Deviation from the spec		-0.47%	$(I1 - Icon_s) / Icon_s$
Meeting the spec. I1 is 3.2mA below the spec.			

Annex B: Calculation with breaking Rload_min and Rload_max to Rch_min, Rch_max and Rpair_PD_min and Rpair_PD_max.

Implication: Rch_min and Rch_max power loss will not be included in Ppd. This will be the most accurate model.

	Inputs		Equation
PSE PI min resistance	Rpse_min	0.1	
PSE output voltage at open load	Vpse	50.14	With correction due to voltage drop
PD input power at the PI including only	Ppd	51	1st iteration
Spec requirements	I _{con_s}	0.683	
	Outputs		
PSE PI max resistance calculated per Eq	Rpse_max	0.161	2.010*Rpse_min-0.04
Rload_min per Table 33B-1	Rload_min	0.623	Table 33B-1
Rload_max per Table 33B-1	Rload_max	1.289	Table 33B-2
Breaking Rload_min and Rload_max to isolate Rpair_PD_min and Rpair_PD_max			
Channel P2P Runb	CP2P Runb	0.07	
Channel resistance_min from PSE PI to PD	Rch_min	0.0869	Rch_min=Rch_max*(1-
Channel resistance_max from PSE PI to PD	Rch_max	0.1	Model parameter at 2.65m
PD PI minimum resistance	Rpair_PD	1.189	Rload_max-Rch_max
PD PI max resistance	Rpair_PD	0.5360	Rload_min-Rch_min
Total pair min resistance from internal	Re2e1	0.723	Rpse_min+Rload_min
Total pair max resistance from internal	Re2e2	1.45	Rpse_max+Rpse_max
Total resistance of positive pairs of the	Re2eP	0.482	Re2e1 Re2e2
Mosfet RDSON	Rdson	0.05	(for the 2-pairs with the same
Rsense	Rsense	0.05	(for the 2-pairs with the same
Total resistance of negative pairs of the	Re2eN	0.582	Re2eN = Re2eP+Rdson+Rsense
Total system resistance from Vpse to Vpd	Re2e&B	1.0649	Rtotal= Re2eP + Re2eN
PD voltage at the constant power sink	Vpd	49.032	Vpd=(Vpse+(Vpse^2-
Total current over 4-pairs	I _{con}	1.0401	I _{con} = (Vpse - Vpd) / Rtotal
Ent to End Runb	E2ERunb	0.3346	(Re2e2-Re2e1)/(Re2e2+Re2e1)
The pair with the maximum current	I1	0.6921	I _{con} *(1-E2ERunb)
The pair with the minimum current	I2	0.3563	I _{con} *E2ERunb
Deviation from the spec [A]		0.0091	I1-I_{con_s}
Deviation from the spec		1.34%	(I1-I_{con_s})/I_{con_s}
Recalculating by subtracting Rpair_PD power loss from Ppd			
Total power loss on Rpair_PD_min and	P_Rpair_P	0.7946	I1*Rpair_PD_min+I2*Rpair_PD_max
PD power of the constant power sink	Ppd_net	50.205	2nd iteration (*)
PD voltage at the constant power sink	Vpd	49.050	Vpd=(Vpse+(Vpse^2-
Total current over 4-pairs	I _{con}	1.0236	I _{con} = (Vpse - Vpd) / Rtotal
Ent to End Runb	E2ERunb	0.3346	(Re2e2-Re2e1)/(Re2e2+Re2e1)
The pair with the maximum current	I1	0.6811	I _{con} *(1-E2ERunb)
The pair with the minimum current	I2	0.3424	I _{con} *E2ERunb
Deviation from the spec [A]		0.0019	I1-I_{con_s}
Deviation from the spec		0.13%	(I1-I_{con_s})/I_{con_s}

We can see the error flipped polarity and still stay small. I1<0.683A thus meeting the spec.

Annex C: Derivation of Rload_max, Rload_min and Rsource_max, Rsource_min.

The following is a short summary of the derivation of some of the PSE and PD pair-to-pair unbalance requirements in 802.3bt **Draft 2.1**.

End to End, Pair to Pair Resistance or Current unbalance (E2EP2PRunb or E2EP2PCunb) is specified by Equation 33D-1.

The term End to End refers to all the components that affect E2EP2PRunb, including components that are in the PSE (See Figure 33B–2 for the PSE side) and in the PD (see Figure 33A–4) (It is not just the Channel components between the PSE PI and PD PI as used in other parts of the specifications).

$$E2EP2PRunb = \frac{(R_{PSE_max} - R_{PSE_min}) + (R_{CH_max} - R_{CH_min}) + (R_{PAIR_PD_max} - R_{PAIR_PD_min})}{(R_{PSE_max} + R_{PSE_min}) + (R_{CH_max} + R_{CH_min}) + (R_{PAIR_PD_max} + R_{PAIR_PD_min})} \quad (33D-1)$$

Where

E2EP2PRunb is the end to end, pair-to-pair effective resistance unbalance between two pairs of the same polarity. The effective resistance includes transformation of pair-to-pair voltage difference (in PSE and PD) to resistance elements at the system maximum operating power. When effective resistance is used, E2EP2PRunb is equal to the end to end pair to pair current unbalance E2EP2PCunb. E2EP2PRunb is a system parameter which was derived from 4-pair model simulations using worst case values of max/min resistance elements of all system components and maximum PSE and PD pair to pair voltage difference. This resulted in worst case system pair to pair effective resistance unbalance as function of channel length in meters and maximum pair current under pair-to-pair unbalance conditions.

R_{PSE_min} , R_{PSE_max} are defined in 33.2.8.4.1.

R_{CH_min} , R_{CH_max} are defined in 33A.4.

$R_{PAIR_PD_min}$, $R_{PAIR_PD_max}$ are defined in 33A.5.

The use of common mode effective resistance simplifies the math used to derive pair-to-pair unbalance requirements by converting all system pair-to-pair voltage difference (such as VPort_PSE_diff which is specified in Table 33-19 or PD pair-to-pair voltage difference which is embedded in equation 33A.4 and in the values of Ipeak_2P_unb_max and in Icon-2P_unb values) to resistive elements in addition to PSE PI and PD PI resistive elements (R_{PSE_min} and R_{PSE_max} in the PSE and $R_{PAIR_PD_min}$ and $R_{PAIR_PD_max}$ in the PD).

When PSE compliance is measured according 33.2.8.4.1 and Annex B, it is verified with Rload_max and Rload_min connected to the PSE. Rload_max and Rload_min are composed of compliant channel resistances, Rch_min and Rch_max as specified in 33A.4, a compliant PD which is represented by the effective resistances RPair_PD_min and RPair_PD_max as specified in 33A.5, and is also a function of R_{PSE_min} and R_{PSE_max} according to equation 33D-2. RPair_PD_min and RPair_PD_max already includes the effect of PD pair to pair voltage difference of 0.06V for Type 3 PDs and 0.05V for Type 4 PDs that will ensure that at high currents, Iport-2P will not exceed Icon-2P_unb as required when PSE is tested for compliance.

$$R_{load_max} = U \times R_{load_min} + U \times R_{PSE_min} - R_{PSE_max} \quad (33D-2)$$

Where:

$$U = \left(\frac{1 + E2EP2PRunb}{1 - E2EP2PRunb} \right)$$

$$R_{load_min} = R_{ch_min} + R_{Pair_PD_min}$$

$$R_{load_max} = R_{ch_max} + R_{Pair_PD_max}$$

PD compliance to the pair-to-pair unbalance requirements of 33.3.8.10 is verified when connected to source voltage with a voltage range of Vport-PSE-2P through the effective resistances Rsource_max and Rsource_min.

R_{source_max} and R_{source_min} are composed from a compliant channel resistance with R_{ch_min} and R_{ch_max} as specified in 33A.4 and a compliant PSE which is represented by the effective resistances R_{PSE_min}, R_{PSE_max} as specified in 33.2.8.4.1 and is also a function of R_{Pair_PD_min} and R_{Pair_PD_max} according to equation 33D-3 which ensures worst case system conditions of PSE, Channel and PD. R_{PSE_min}, R_{PSE_max} already includes the effect of PSE pair to pair voltage difference of 0.01V for Type 3 PSE and Type 4 PSE that will ensure that at high currents, I_{port-2P} will not exceed I_{con-2P_unb} as required when PSE or PD is tested for compliance. See 33A.5 for design guidelines for PD PI effective resistance R_{Pair_PD_min} and R_{Pair_max}.

$$R_{Source_max} = U \times R_{Source_min} + U \times R_{Pair_PD_min} - R_{Pair_PD_max} \quad (33D-3)$$

Where:

$$U = \left(\frac{1 + E2EP2PRunb}{1 - E2EP2PRunb} \right)$$

$$R_{Source_min} = R_{ch_min} + R_{PSE_min}$$

$$R_{Source_max} = R_{ch_max} + R_{PSE_max}$$

The E2EP2PRunb that was used to derive the U value in Equations 33D-2 and 33D-3 above is found at short cable in order to find the worst case unbalance due to the fact that with long cables the unbalance is improved. Maximum pair current due to E2EP2PRunb is not always obtained at the maximum value of E2EP2PRunb. For Type 3 systems, maximum pair current is obtained at R_{chan-2P}=0.2Ω (short cable) where E2EP2PRunb is the highest. For Type 4 systems, maximum pair current is obtained at R_{chan-2P}=12.5Ω (at 100m channel length) where E2EP2PRunb is the lowest.

REFERENCES:

http://www.ieee802.org/3/bt/public/oct15/darshan_01_1015.pdf

Annex D: 4-pair models and its database

For more details see pair-to-pair unbalance adhoc material.

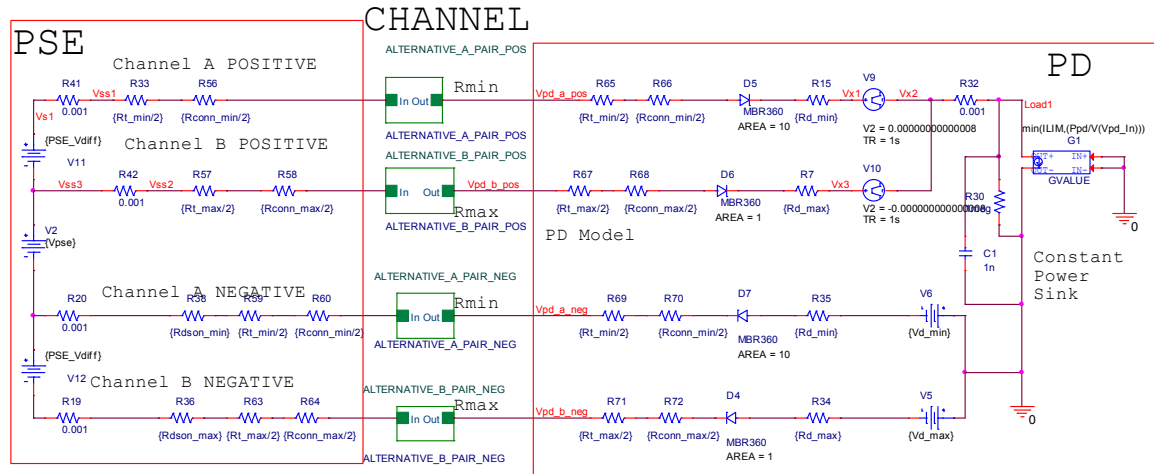

#	component	Value	
1	Vpse	50.3	
2	PSE_Vdiff	10mV	
3	Pd_Vdiff	60mV	
4	Cable P2PRunb	5%	
5	Pair unb	2%	
6	Ppd	51W	
7	Cable length (Lcable)	2.65m	
8	Cordage Resistivity (per wire)	0.0926Ω/m	
9	Cable resistivity (per wire)	0.076Ω/m	
10	Resistivity=0.1*Cordage_resistivity+0.9*Cable_Resistivity		
11	Rcable_max=Lcable*Resistivity		

#	component	Value [Ω]	
		max	min
12	Rt	0.13	0.12
13	Rsense	0.25	0.245
14	Rdson	0.1	0.07
15	Rcon	0.05	0.03

Channel model for all 4 pairs:

