

145.2.5.6 Functions: Add option_class_probe_only.

option_class_probe_only

This variable indicates if the PSE should return to IDLE following the completion of do_class_probe.

Values:

FALSE: The PSE will proceed to CLASS_RESET.

TRUE: The PSE will return to IDLE.

145.2.5.6 Functions: Add pri and sec versions of do_class_probe.

do_class_probe

This functions discovers the PD requested Class by producing a number of class events. The class events produced are limited to CLASS_EV1_LCE to MARK_EV3. The tlce_timer in CLASS_EV1_LCE may be replaced with the tcle2_timer to allow abbreviated class timing duration. This function returns the following variables:

pd_req_pwr: This variable contains the PD requested Class.

Values:

- 0: Class 0
- 1: Class 1
- 2: Class 2
- 3: Class 3
- 4: Class 4
- 5: Class 5
- 6: Class 6
- 7: Class 7
- 8: Class 8

do_class_probe_pri

This functions discovers the PD requested Class by producing a number of class events on the Primary Alternative. The class events produced are limited to CLASS_EV1_LCE_PRI to MARK_EV3_PRI. The tlce_timer_pri in CLASS_EV1_LCE_PRI may be replaced with the tcle2_timer_pri to allow abbreviated class timing duration. This function returns the following variables:

pd_req_pwr_pri: This variable contains the PD requested Class for the Primary Alternative.

Values:

- 1: Class 1
- 2: Class 2
- 3: Class 3
- 4: Class 4
- 5: Class 5

do_class_probe_sec

This functions discovers the PD requested Class by producing a number of class events on the Secondary Alternative. The class events produced are limited to CLASS_EV1_LCE_SEC to MARK_EV3_SEC. The tlce_timer_sec in CLASS_EV1_LCE_SEC may be replaced with the tcle2_timer_sec to allow abbreviated class timing duration. This function returns the following variables:

pd_req_pwr_sec: This variable contains the PD requested Class for the Secondary Alternative.

Values:

- 1: Class 1
- 2: Class 2
- 3: Class 3
- 4: Class 4
- 5: Class 5

Modify Figure 145-13 to allow return to IDLE after CLASS_PROBE

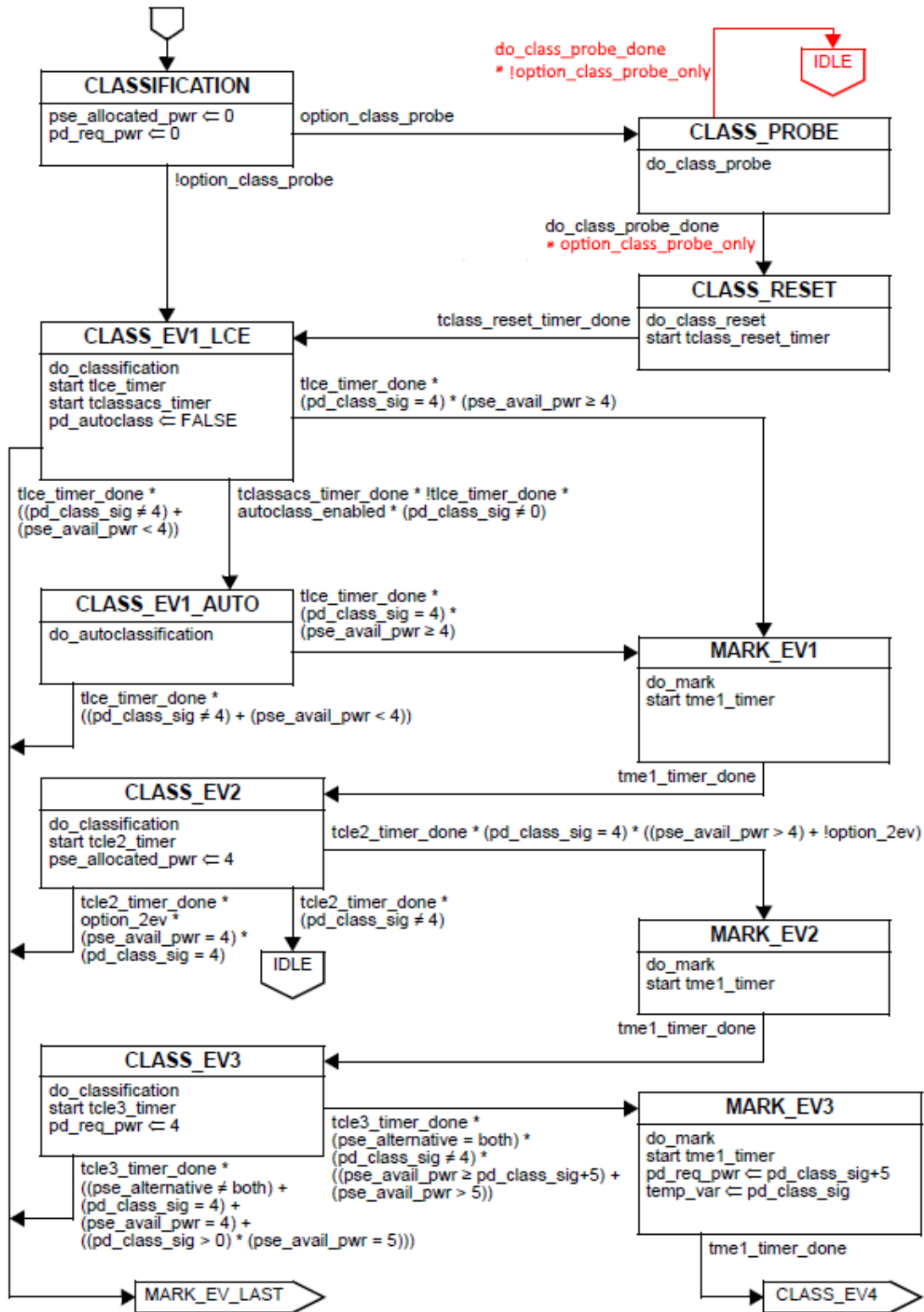

Modify Figure 145-15 to allow return to IDLE_PRI after CLASS_PROBE_PRI

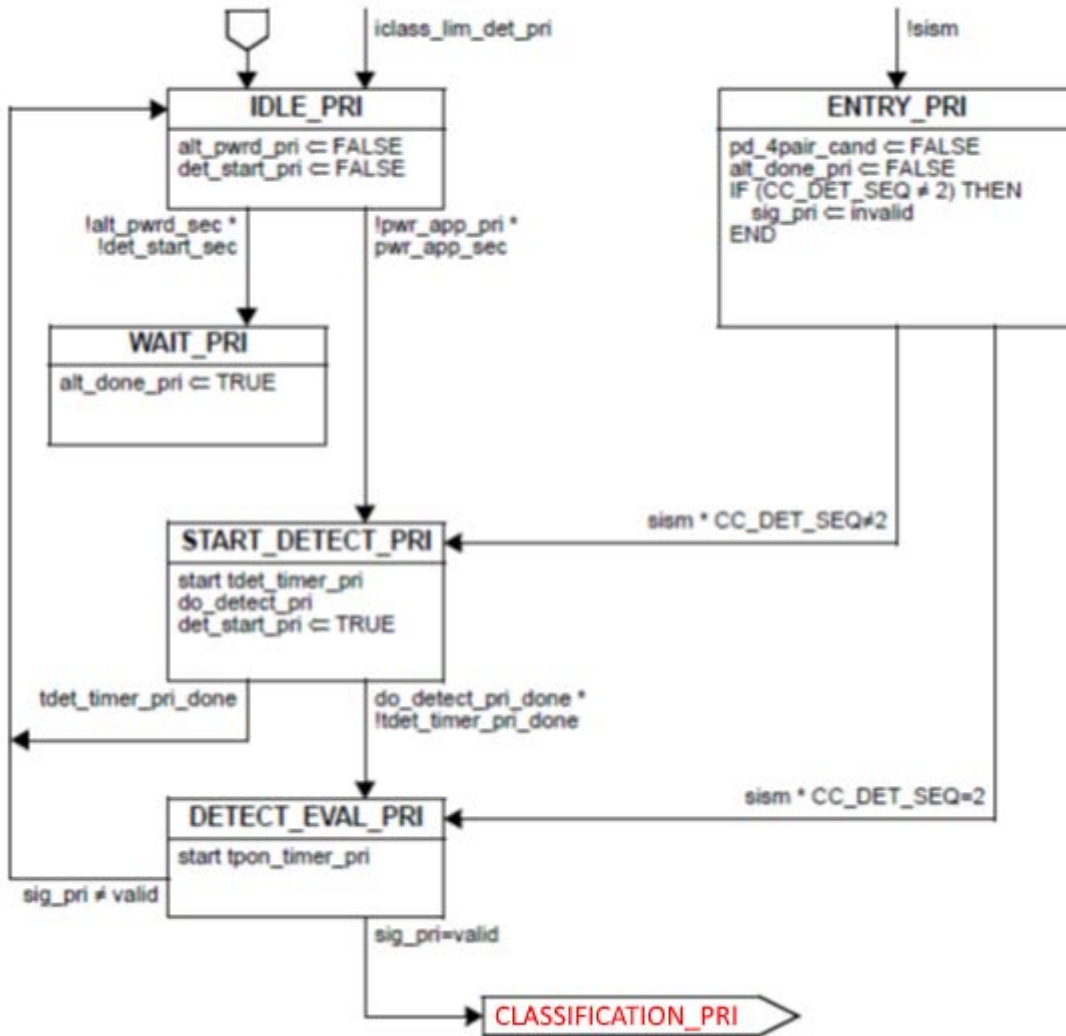

Modify Figure 145-15 to allow CLASS_PROBE_PRI

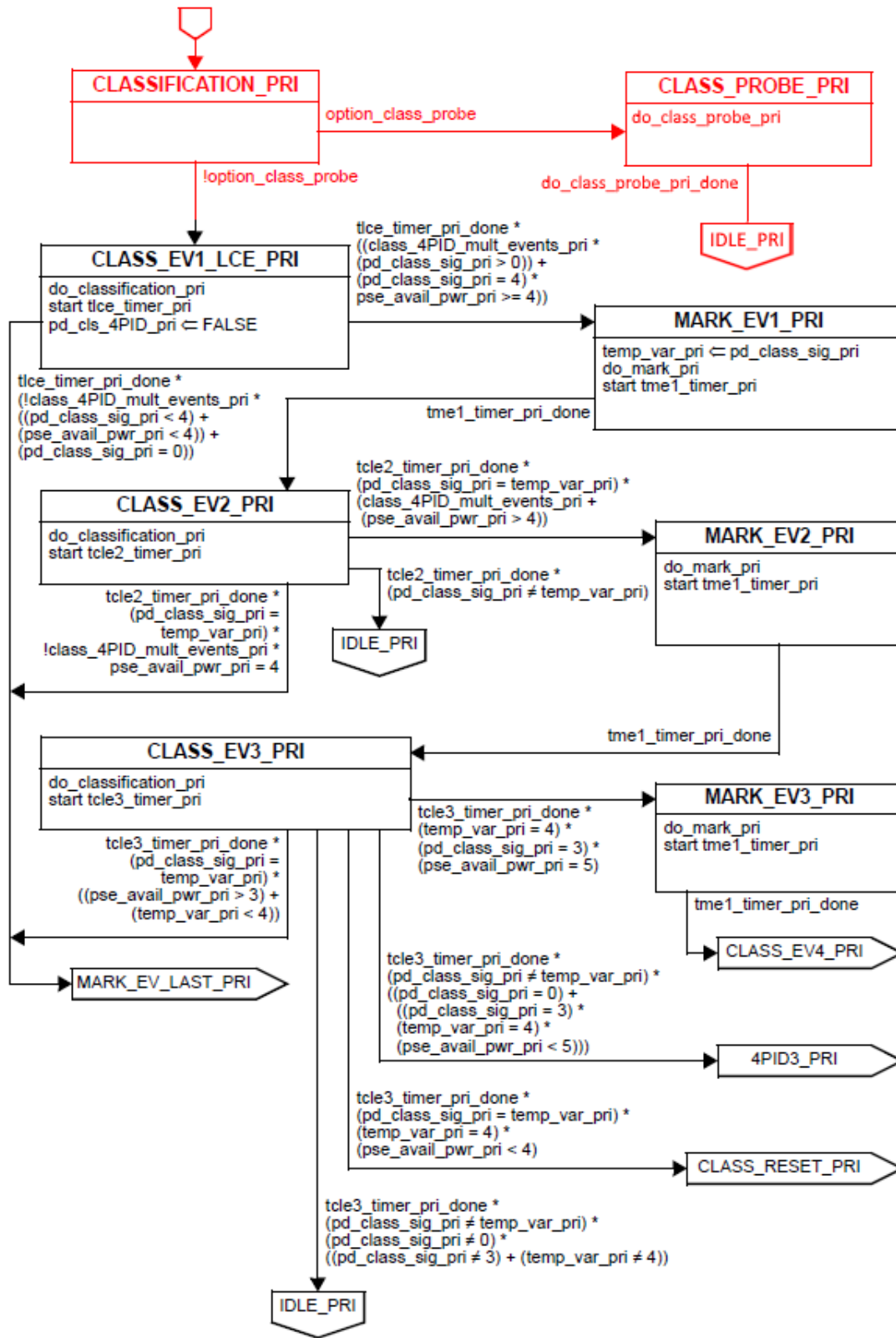

Modify Figure 145-16 to allow return to IDLE_SEC after CLASS_PROBE_SEC and to allow option_class_probe to proceed into detection

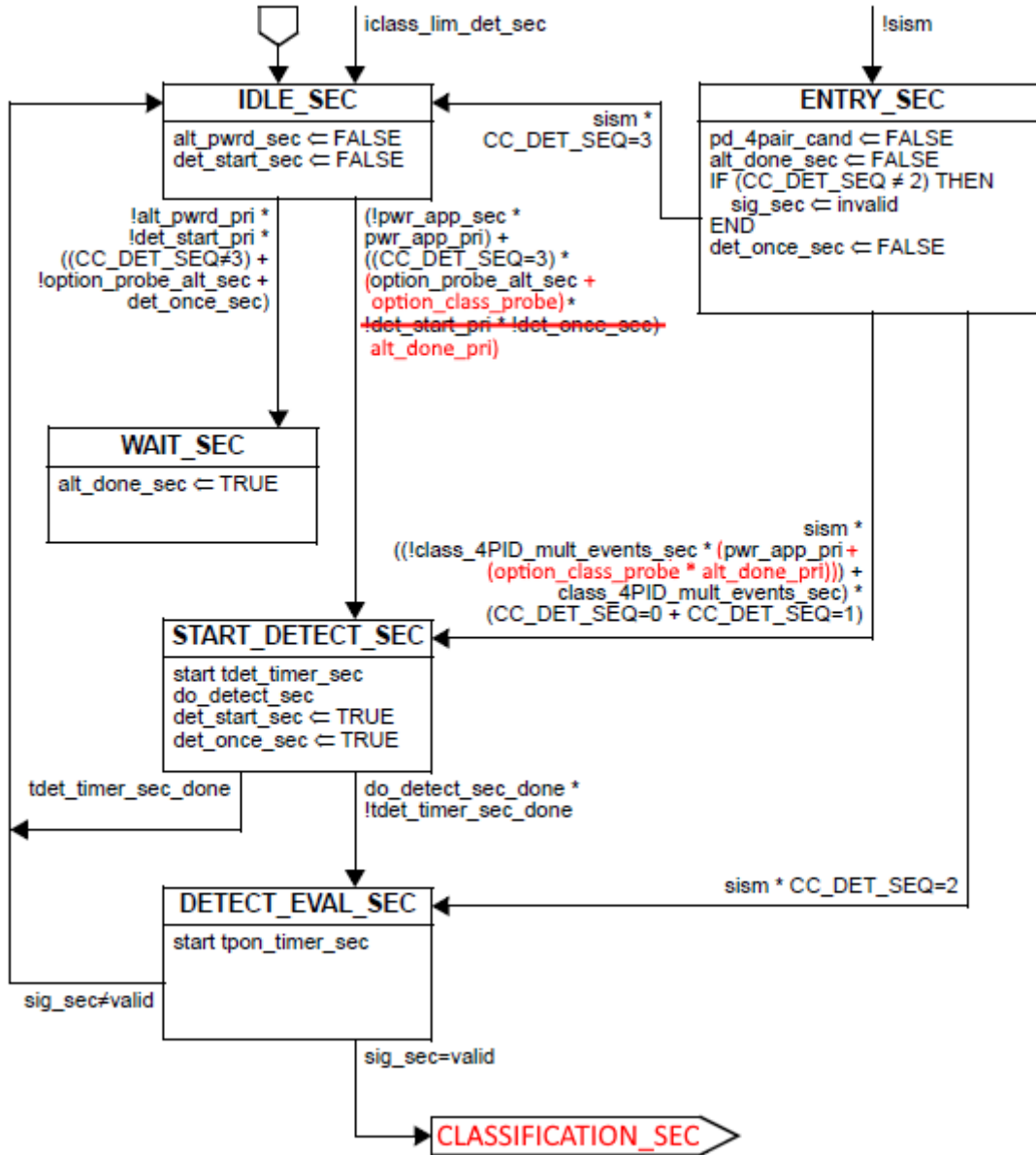

Modify Figure 145-16 to allow CLASS_PROBE_SEC

