



Backfeed voltage during 2, 3 and 4 pair operating modes

May 2018
Yair Darshan
Rev004

ydarshan@microsemi.com

Objectives

- To investigate the effect of excluding backfeed requirements for 3-pair mode.
- To check if and in which parts, the IEEE802.3bt D3.4 need to be updated as a result.

Backfeed requirement.....1

145.3.8.8 Backfeed voltage

“When any voltage in the range of 0 V to $V_{Port_PD-2P\ max}$ is applied across the PI at either polarity specified on the conductors of either Mode A or Mode B¹ according to Table 145–20¹, the voltage measured across the PI for the other Mode with a 100 k Ω load resistor connected across that other Mode shall not exceed V_{bfd} as defined in Table 145–29.”

(1) “.. on the conductors of either Mode A or Mode B..” is 2-pair or 3-pair per Table 145-20

V_{bfd} Must be less than 2.8V over 100K Ω

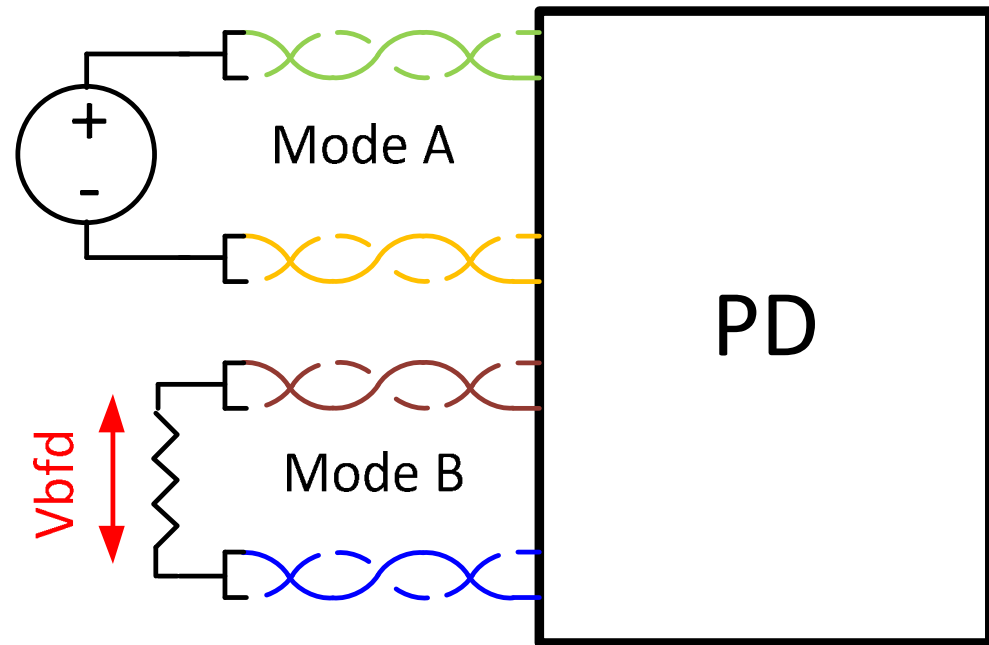

Backfeed requirement.....2

- The backfeed specification¹ in D3.4 applies for 2-pair and 3-pair mode per Table 145-20 in the 2-pair mode section.

1. Originally came from 802.3af/at for 2-pair PSEs

In addition (Backfeed=PD sourcing power):

There is a requirement: **“PD shall not source power to the PD PI”**

-Added to the spec to cover auxiliary PD power supply connection that its voltage and current capacity are not limited/specified by the spec.

Table 145-20—PD input power configurations

Pairsets	Mode A		Mode B	
	Pair 1	Pair 2	Pair 3	Pair 4
Conductor	1 and 2	3 and 6	4 and 5	7 and 8
Valid 2-pair configurations				
	P	N	—	—
	N	P	—	—
	—	—	P	N
	—	—	N	P
	P	N	P	—
	P	N	—	P
	N	P	P	—
	N	P	—	P
	P	—	P	N
	—	P	P	N
	P	—	N	P
	—	P	N	P
Valid 4-pair configurations				
	N	P	N	P
	N	P	P	N



Topics that we already discussed

#	Subject	Annex
1	References for backfeed specifications	A
2	Why backfed is 2.8V/28uA max	B
3	The reasons for backfeed specification	C
4	The reasons for backfeed specification: Detection pollution	D
5	List of issues to resolve/investigate	E
6	Potential damage to detection circuitry during Detection to legacy Endspan/Midspan configurations and existing 4-pair PSEs	F
7	Endspan/Midspan configuration	G
8	PSE is connected to SSPD through crossed cable	I, H
9	Increasing PSE susceptibility to cross leakage current issues between pairs/ports.	J
10	Addressing dual-signature PDs	K
11	PD with Auxiliary power supply damage PSE and PDs	

Reasons to include 3-pair mode in backfeed spec



- “Worry Free” and It keeps the same intent we had for true 2-pair mode
 - It is, after all, “2-pair” mode with reinforced positive leads...
 - Well defined requirement to a PD to not source power back to the PSE.
 - **Backfeed = sourcing power!** “The PD shall not source power on its PI ”
 - PSE and PDs will damage if excluding 3-pair when PD Aux power supply voltage will be $> V_{pse}$ or $> 57V$ and also their current has no limit.
 - Prevent wrong Ideal diode bridge designs which need to have identical behavior to diode based designs, with improved efficiency.
 - Prevent potential damage or improper operation or interoperability issues (will be addressed case by case if it is a valid concern)
 - Prevent confusion when using rectifier designs intended for SSPDs with DSPDs where they will violate the spec in DSPDs¹.

(1) This argument may be weak since we can make the spec more clear that DSPDs need to meet both valid signature and backfeed requirements on each pair.....



Reasons to **exclude** 3-pair mode in backfeed spec



- Allow some low cost Ideal Diode Bridge designs.
- **This argument is weak.** Can be fixed and stay low cost....
- *Existing Legacy 802.3af/at and pre 802.3bt standard already exhibit high back feeding voltage under 3-pair mode. Compliant Type 3 and 4 PSEs may need to deal with it anyway.*
- 4-pair PSE that operates over 4-pair and is connected to **single-signature PD** will not be affected by backfeed.
 - POWER_UP on both pair sets will occur long after CC and detection/classification over each pairset are done, hence a 4-pair PSE is capable of handling the high backfeed voltage.
- Dual-signature PDs will have to meet backfeed requirements in 2-pair, 3-pair and 4-pair modes, otherwise detection will fail.

Problem #1 with the existing text vs. exiting legacy and pre 802.3bt standard PDs implementations

- Some Ideal diode bridges in the market used with Type 1 and 2 PDs and pre-802.3bt SSPDs will fail to meet the backfeed requirement when operated in 3-pair mode¹. **Designers didn't verify that this specific implementation doesn't 100% match diode bridge behavior, which doesn't have the backfeed issue in 3-pair.**
 - in most 4-pair PSE implementations, all positive leads are tied together and only the negative leads are switched. This results in 3-pair mode when a 4-pair PSE is powering over 2-pair

Note 1: Found during the last Plug Fest when pre-standard 802.3bt PDs are connected to pre-standard 802.3bt PSEs

The current text support SSPDs and DSPDs in all operating modes: 2P, 3P, 4P.

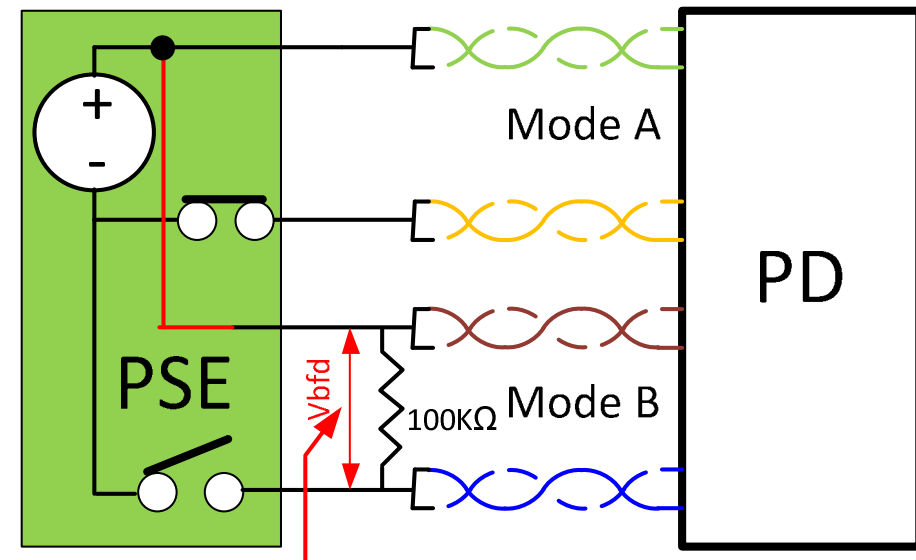

Should we keep V_{bfd} requirements for 3-pair mode or exclude 3 pair mode?

Issues with excluding 3-pair: PDs with wall adaptor

- They are allowed by the standard
- Their maximum voltage and current limits are not specified
 - It is not a problem if backfeed includes 3-pair
- ***if excluding 3-pair from backfeed=2.8V/28uA, the PD may source power which is not acceptable!!!***
 - Voltage > V_{pse_min} . PD aux power supply will replace PSE PS and power all the ports and will damage the PD aux power supply
 - Voltage > 57.
 - It will damage PSE
 - Violate the safety spec (SELV).
 - PD aux power supply will replace PSE PS and power all the ports and will damage the PD aux power supply

Issues with excluding 3-pair: PDs sourcing power with wall adaptor

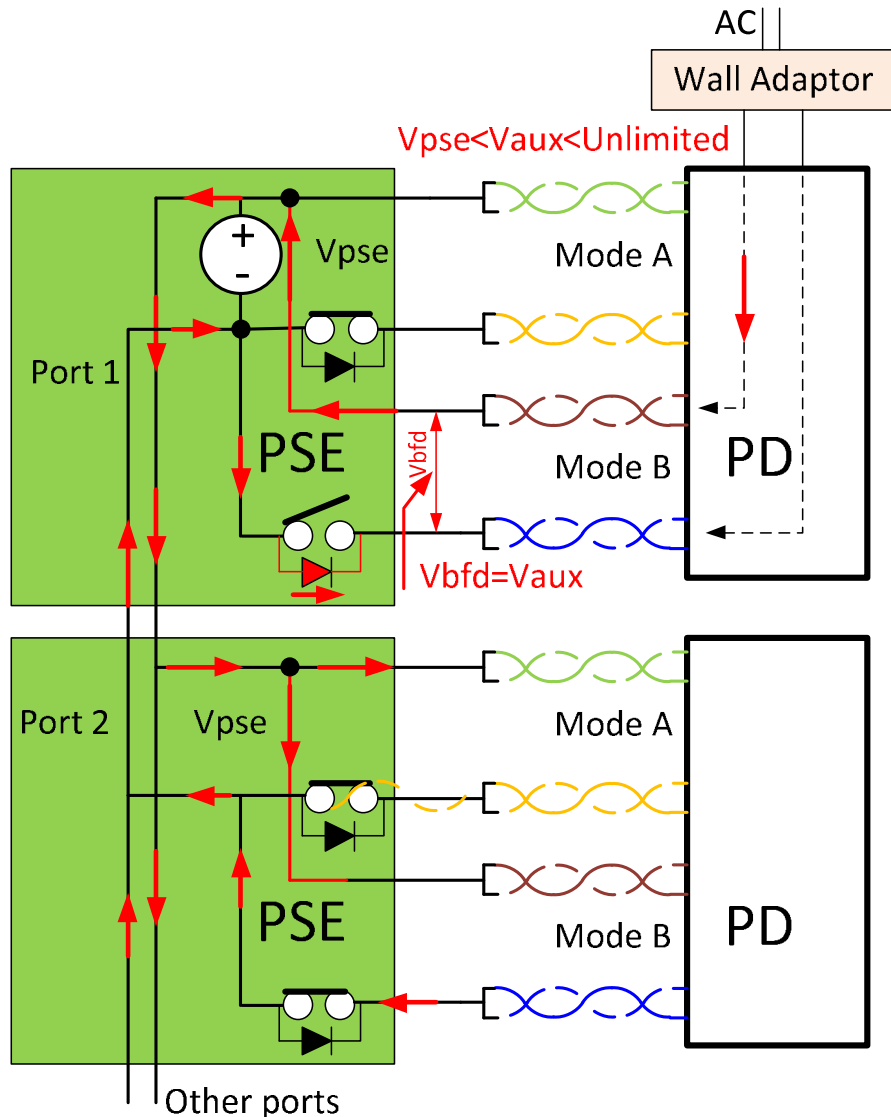

- Risk of damaging:
 - PSE (If $V_{aux} > 57V$)
 - PSE MOSFET body diode of port #1 ALT B
 - PD (Aux supplies all the power to the 1KW PSE load....)
- Need to keep the requirement that PD shall not source power
 - In 2-pair, 3pair and 4piar when aux PS in the PD is active.
 - In 2-pair SSPD when PSE is active.
 - In dual-signature PDs for 2/3/4-pairs
 - Shall not source power mean $\leq 2.8V$, $\leq 28\mu A$

Summary of remaining issues



#	Concern	Results	Recommendations
1	Damage to existing 4-pair designs during detection. Spec limits to 30V. Now they will be exposed to 57V max.	2 vendor tested. No issues.	To require PSE to meet backfeed of 0-57V in 3-pair for all operating states with "positive polarity"
2	PDs that equipped with auxiliary power supply per 145.3 page 186 line 43-44 with no spec that limits its voltage and current which now may source voltage/power and damage PSE, PD and violates safety specs.	Confirmed	To add: -"PDs shall not source power to the PI when auxiliary power supply (wall adapter) is active in 2-pair, 3-pair and 4-pair." -"SSPDs shall not source power in 2-pair mode." -"DSPDs shall not source power." -To "not source power" means: 2.8Vmax, 28uA max as in backfeed.
3	Susceptibility to increased leakage current that pollutes detection on adjacent pairs/port that is doing detection. Normally, backfeed is 57V max with 28uA current limit. If we exclude 3-pair, it will be 57V with ILIM-2P limit which is unlimited leakage source.	2 vendor tested. Leakage current was increased as expected but still low.	-If we will have time, to show the simulation model for the root cause. -Meanwhile, to add text to PSE section that "PSE port that is doing detection (or classification?) shall not be polluted by backfeed voltages of unpowered pairs" or equivalent text.

Solution: Option 1 (preferred, lower risks)



- Allows PSEs to support PDs with 3-pair backfeed issue
- Prevents propagating risks to the standard (and to PSEs and PDs) for new PDs to have backfeed issue at 3-pair mode (***unless group will focus on finding issues and address them which in this case we may go to solution 2***) 
- **PD spec:**
 - Keep the text as is. It requires Type 3 and 4 PDs to meet backfeed in 2-pair, 3-pairs and also covers DSPDs.
- **PSE spec:**
 - To require Type 3 and 4 PSEs to operate Type 1 and 2 PDs that doesn't meet backfeed in 3-pair mode.
 - System work (problem #2) : To continue to check if Type 3 and 4 PSEs may experience issues when exposed to backfeed of VPort_PD-2P max=57V and no current limit¹ compared to 28uA current limit as it was.
 - May cause interoperability issues and/or damage
 - **Our spec should not allow potential damage to existing equipment in the field**
 - **This investigation will allow us to see if we need more PSE text to cover all new issues as a result of supporting PDs with backfeed issues.**

Note 1: The current is limited by ILIM-2P at the powered pair

Solution: Option 2

- Allows PSEs to support PDs with 3-pair backfeed issue
- Allows PDs with backfeed issues in 3-pair mode. This can only be possible if the whole group ***will focus on finding issues and address them so will not not create bigger problems otherwise we will have to go to option 1)***
- PD spec:
 - Exclude 3-pair from backfeed requirement for SSPDs.
 - Ensure that dual-sig is covered with a new text for DSPDs.
 - To add text to address auxiliary power supply sourcing power problem
- PSE spec:
 - To require Type 3 and 4 PSEs to operate Type 1, 2, 3, 4 PDs that doesn't meet backfeed in 3-pair mode.
 - System work (problem #2): To continue to check if Type 3 and 4 PSEs may experience issues when exposed to backfeed of VPort_PD-2P max=57V and no current limit¹ compared to 28uA current limit as it was.
 - Our spec should not allow potential damage to existing equipment in the field
 - This investigation will allow us to see if we need more PSE text to cover all new issues as a result of supporting PDs with backfeed issues.

Note 1: The current is limited by ILIM-2P at the powered pair

Next steps/Recommendations



- We need the group/system vendors to look for use cases that may cause damage or interoperability issues if we exclude 3-pair from backfeed requirements.
 - Based on these data, to add the necessary text to PSE and PD spec
- **To explain how the leakage current affects detection**
 - **To explain why the question how “leakage affect detection if PSE is designed to supply voltage up to 57V” is not relevant to the root cause of the leakage issue**

Discussion (in RED, new inputs for today's meeting)

- To add text that PSE has to meet:
 - 0-57V in all its operating modes for infinite time (excluding voltage with reverse polarity applied to the PI).
 - Limit the current draw to 57V/45K
 - Yair: The reverse polarity doesn't include the case when PSE is trying to detect another PSE
- To modify the backfeed text per the final decision (exclude 3-pair or include 3-pair in backfeed). This is subject to how many issues were found and addressed and how many left.
- To modify the text **“The PD shall not source power on its PI per the limits in Table 145-xxx.”**

Item	PD signature configuration	Max voltage	Max Current	Operating conditions
1	Single-Signature	2.8V	28uA	2-pair
2	Single-Signature	2.8V	28uA	4-pair, during detection, and classification
3	Single-Signature	VPort_PD-2P	ILIM-2P	3-pair when the PD power source is a PSE.
4	Single-Signature	2.8V	28uA	2-pair, 3-pair, 4-pair when the PD external power supply is active
5	Dual-signature	2.8V	28uA	2-pair, 3-pair, 4-pair

Annexes

Annex A - References

- http://www.ieee802.org/3/af/comments/d4.2/P802_3af_D4_2_all_page_line.pdf
comments 10 and 12 page 11 addressing the question why we need backfed spec. Comment in comment 10 I showed the field report for why backfeed is a must.
- The backfeed requirement was added at the last cycle of the 802.3af meeting after a field report results. In addition, a note was added (to complete the info as shown in comment #101 page 23 at:
http://www.ieee802.org/3/af/comments/d4.1/P802_3af_D4_1_all_by_page.pdf

Annex B – Why backfeed parameters is 2.8V, 28uA, 100K



Why 2.8V?

- To limit the voltage in order not to damage Bob-smith terminations in a Switch. The resistor of the termination was limited to 0805 package (0.125W) → $2.8V^2 / (2 * 75) = 0.052W < 0.125W$.
- PD auxiliary power supply will not generate >2.8V on an unpowered mode in order to allow PSE detection.
- In addition, 2.8V is minimum detection range and PSE OFF voltage, resulting with well defined behavior in all PD and PSE operating modes

Why 28uA?

- 28uA is the maximum leakage current allowed at worst case PD operating conditions on an unpowered mode that will create maximum of 2.8V over 100K test resistor.
- All Mode B diodes are reversed bias represented by high resistances R1, R2, R3 and R4 with $R = R_{min} = 1M\Omega$ min.
- $I_{LEAK_max} = (57V * (R4 / (R3 + R4) - R2 / (R1 + R2))) / R_{eqv}$
- $I_{LEAK_max} = 0$ If all diodes equal, else $I_{LEAK_max} > 0$
- With $R4 = 10 * R3 = 10 * R$ and $R1 = 10 * R2 = 10 * R$ (worst case assumption) →
 - $V_{eqv} = 57 * 9 / 11$, $R_{eqv} = 2 * 10 * R / 11$, $I_{leak_max} = 25.65\mu A$ → rounding up to 28uA
 - Convert I_{leak_max} to voltage with 100K sense resistor → 2.8V as needed.

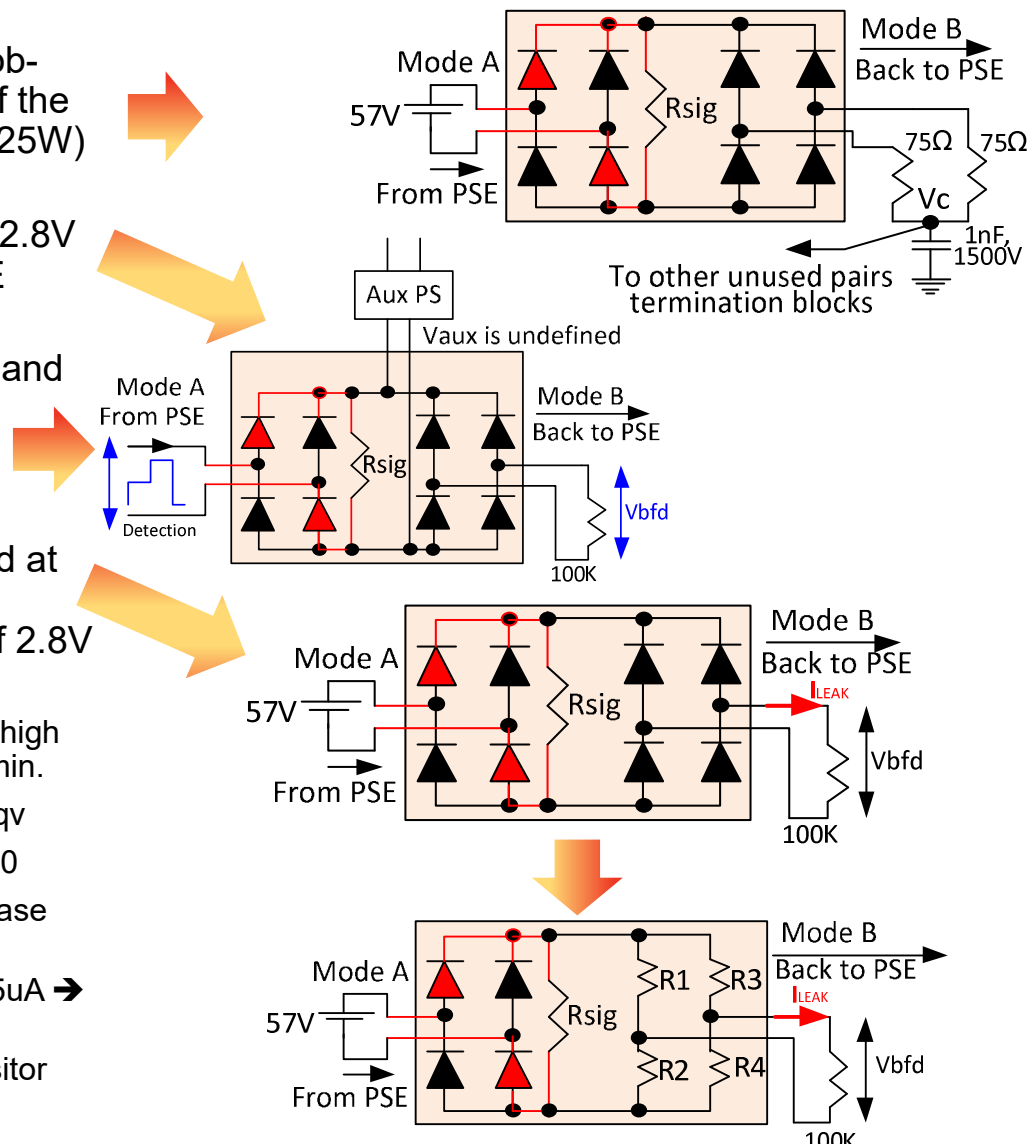

Annex C :The reasons for backfeed specification

- To prevent pollution of adjacent PSE ports
 - In some PSEs, poorly DC-isolated Bob Smith terminations can couple PD Backfeed to adjacent ports, resulting in corruption of the detection signature
- To prevent damage to non PSE pairs with low impedance terminations
- To set a well-defined behavior of an unpowered PD mode
 - Backfeed below the PSE minimum OFF/detection voltage value.
- To meet **“The PD shall not source power on its PI ”**
 - To handle PD auxiliary power supply with no spec that limits its voltage/power
- To prevent damage to Endspan or Midspan configuration when one of them is OFF.
- In unpowered mode of a Dual-signature PD, PD should show valid detection AND backfeed voltage <2.8 to allow PSE successful detection.

Annex D: The reasons for backfeed specification: Detection pollution

- 2-pair multiport PSE
- “BST” is a termination module, contributing to port to port cross-leakage
- If BST is poorly designed, the 2nd PSE will not be able to detect and powerup.
- **“From clause 33 and 145:
“In a multiport system, the implementer should maintain DC isolation through the termination circuitry to eliminate cross-port leakage currents. “**

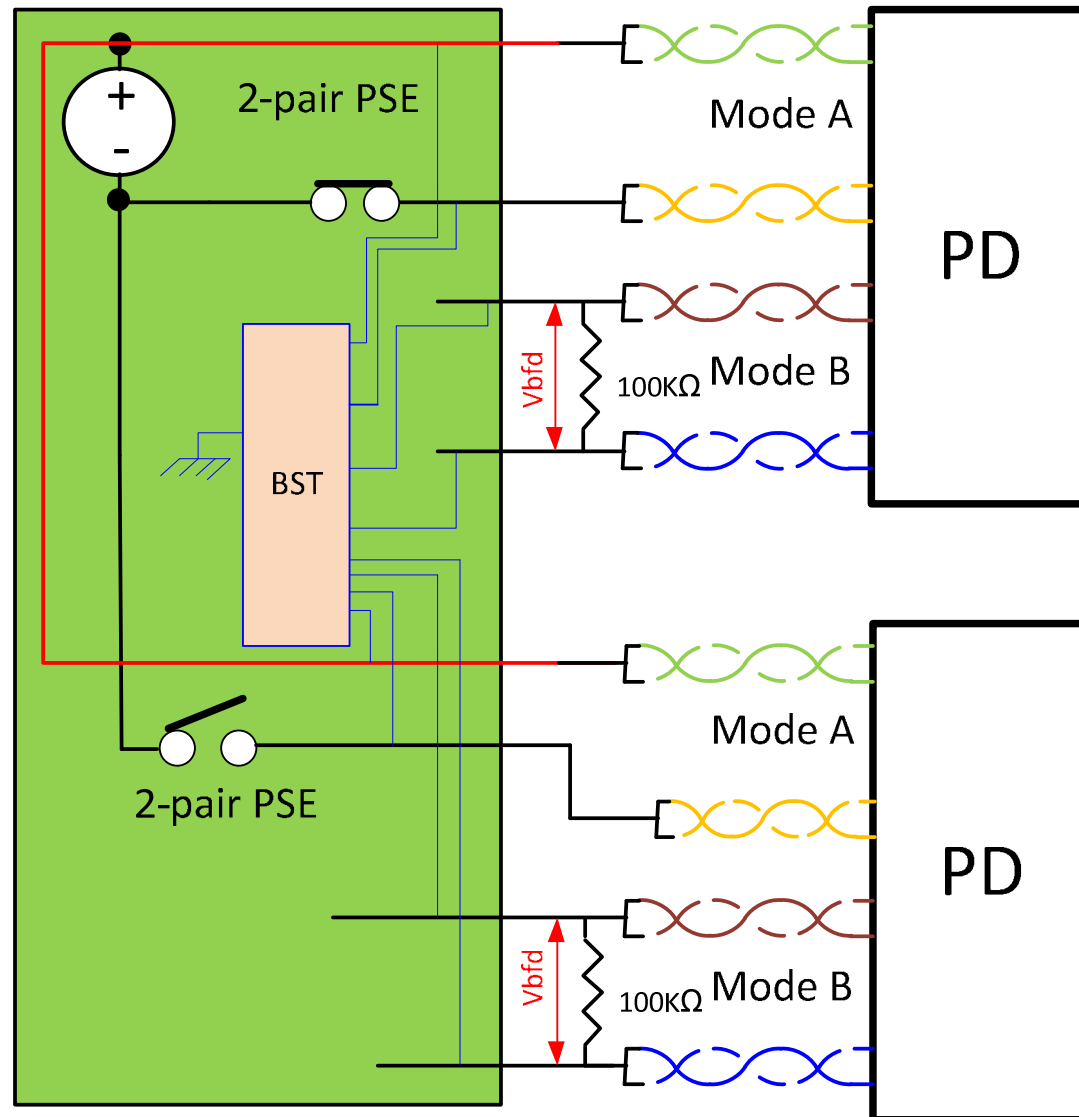

Annex E: List of issues to resolve/investigate

List of issues to address in order to resolve problem #2

- Test conditions: Applying high backfeed voltage (VPort_PD-2P) to the unpowered pair of a 4-pair PSE when connected **to an ideal diode bridge from a schematic that was supplied to me¹**, in the following cases and checking for:

- damage to existing 4-pair PSE detection circuitry that was used to see up to 30V during detection and backfeed voltage up to 2.8V and now may see backfeed voltages up to 57V.
- PDs using wall adapters. If excluding 3-pair, PSE or PD or bot will be damaged since maximum voltage and current are not specified.
- Damage or interoperability issues in a typical Endspan/Midspan configuration
- When a PSE is connected to a SSPD through crossed cable: Damage to the detection diode across the PI due to reverse polarity¹?

When a PSE is connected to SSPD through crossed cable: safety (>60V) between the two modes¹?

- increasing PSE susceptibility to cross leakage current issues that will prevent successful detection on adjacent pairs/ports (now leakage may be higher by $57V/2.8V \approx 20$)
- **Other? Group/system vendors need to check for other use cases to ensure we are not creating problems in such late stages of the standard.**

Annex F: Potential damage to detection circuitry during Detection to legacy Endspan/Midspan configurations and existing 4-pair PSEs

- Detection circuitry has to handle up to 57V and not 30V as in typical diode based bridge designs.
- **Vendor1 results: PSE ok at 57V and power dissipation for any duration.**
 - Details: $R_{dson} \cdot I_{port}^2 > 57^2/R$ per port → No issues
 - R is the PSE output resistance across the PI during OFF/DETECTION state
 - Increasing R has no significant value compared lowest possible R. The minimum value of R (R_{min}) must be $R_{min} \geq 45K$ to meet spec. **See note 1.**

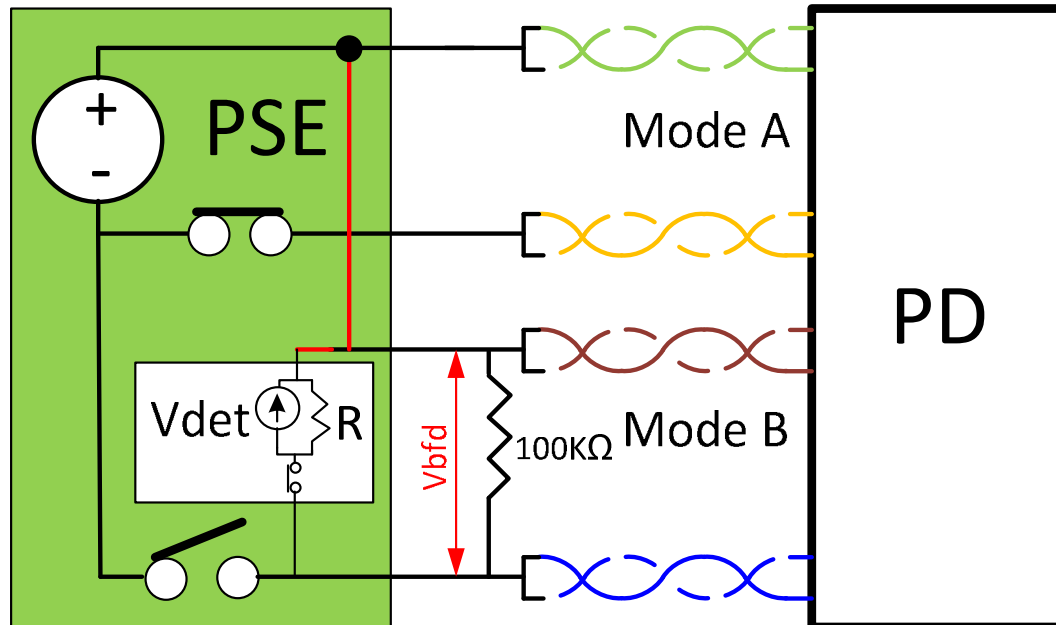

Note 1:

having R close to $R_{min} \geq 45K$ during OFF/Detection states is advantage compared to $R > R_{min}$ since it allows fast discharge of PD input caps and make PD ready for next new detection faster.

Annex G: Endspan/Midspan configuration

- Since a Midspan, when connected to Endspan, breaks the DC continuity over at least one positive pair, ***the 3-pair mode is avoided*** which results in true 2-pair mode operation, which meets the backfeed requirement.
- **Conclusions: No issues with Endspan/Midspan configurations**

Annex H: PSE is connected to SSPD through crossed cable - 1

- To verify that when a crossed cable is used, the unpowered PSE alternative doesn't experience reversed voltage that could damage the detection diode across the PI (Figure 145-19 and 145-20).
- **Analysis results:** per the specific ideal diode bridge schematic that I have received, which generates backfeed (VPort_PD-2P) in 3-pair mode:
 - The root cause of the high backfeed voltage on the unpowered pair is that the two control circuits of the two Ideal diode bridges get the positive pair voltage since they are both tied together at the PSE. This causes the relevant negative side MOSFET in the ideal diode bridge to be ON, on the unpowered pair which in turn generates the high backfeed voltage (instead of staying OFF as it would in a diode bridge implementation).
 - The bridge still determine its polarity only as a function of its input voltage independent of the 2nd bridge, resulting in the correct backfeed voltage polarity at the unpowered PSE alternative.
- **Conclusion: No issues with crossed cables**

Annex I: PSE is connected to SSPD through crossed cable - 2

- To verify that when a crossed cable is used, the unpowered PSE alternative doesn't experience reversed voltage which would cause $>60V$ between the modes in Midspan/Endspan configurations
- **Analysis results**
- **3 arguments that each alone is sufficient to claim NO ISSUES:**
- There is no risk of $>60V$ between modes when the PD is single-signature, since any pairs of the same polarity are clamped to each other by the PD diodes.
- In addition, there is no reverse polarity issue in the mentioned ideal diode bridge behavior.
- Since a Midspan, when connected to Endspan, breaks the DC continuity over at least one positive pair, ***the 3-pair mode is avoided*** which results in true 2-pair mode operation which meets the backfeed requirement.

Annex J: increasing PSE susceptibility to cross leakage current issues between pairs/ports.

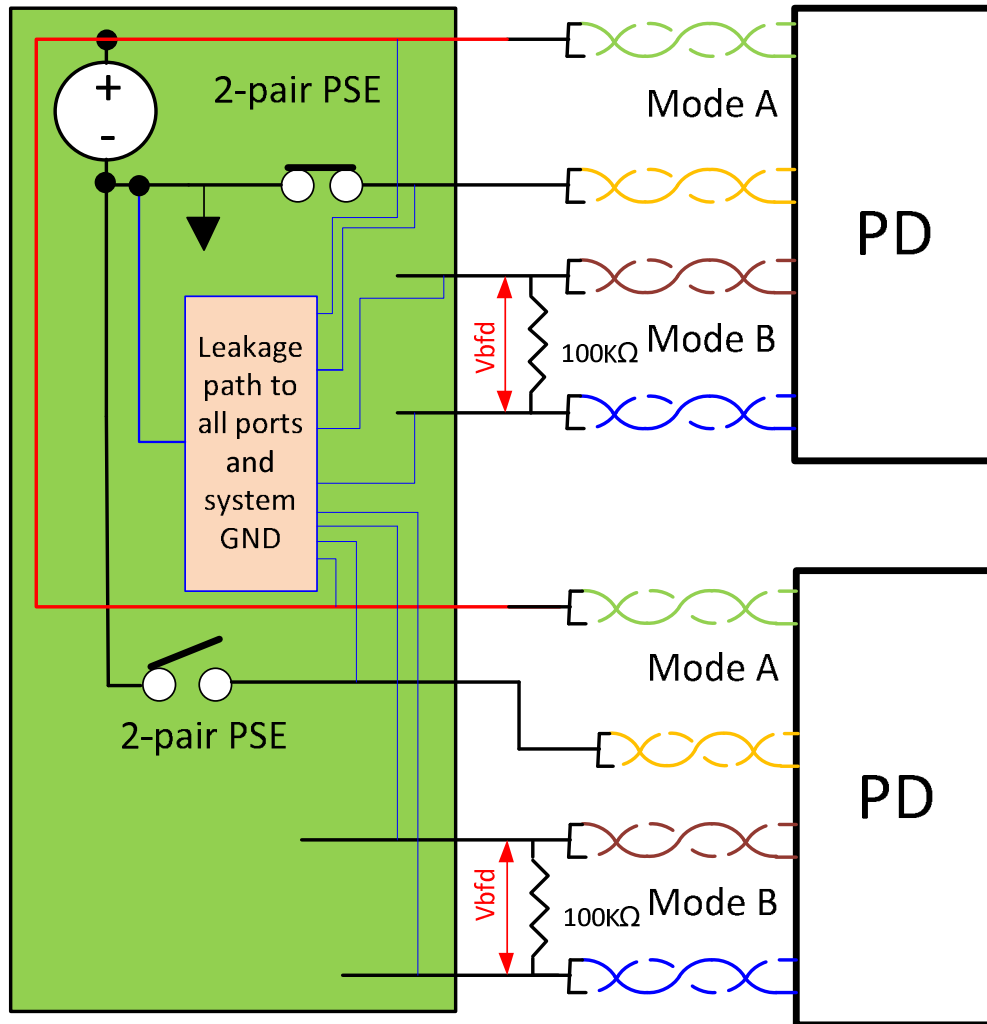

- Allowing high backfeed voltage up to 57V may increase existing 4-pair design and legacy 2-pair design susceptibility to cross-leakage current by a factor of up to ~20 ($57V/2.8V$) and may prevent successful detection on adjacent pairs/ports.
- *I checked Vendor1 system and leakage current is still sufficiently low at 57V so detection is not polluted.*
- **Need data from other PSE systems to ensure backwards compatibility.**

Annex K: Addressing dual-signature PDs

- The current text looks like it covers both single-signature and dual-signature PD, however dual-signature PDs must meet backfeed for any valid configuration in Table 145-20 (2-pair, 3-pair and 4-pair) and we need to ensure this in the final text of backfeed, if it is going to be changed.

