

1. Comment [r01-462](#) - Updating Figure 145-22 page 168 line 35, Figure 145-31 page 207 line 22 to sync with proposed text in comments [r01-286](#), [r01-287](#).
2. Addressing comment [r01-378](#) regarding the need to split Rsource_min/max to Rsource1_min, Rsource2_min and Rsource1_max, Rsource2_max for setting the correct PSE voltage at the PSE PI to allow adjusting Vsource to get VPort_PSE-2P at the PSI PI. [This comment is addressed in a simpler way.](#)

Per the latest changes we did to include equipment connector in the PSE PI and in the PD PI for unbalance tests the following changes should be made:

- a) Figure 145-22, the borders of the test verification model need to be clearly shown.
- b) Figure 145-31 and NOTE 1 in line 33 need similar adjustments.

Proposed remedy:

1. *Change the title of Figure 145-22 from:*

"Figure 145-22—PSE PI unbalance specification and system resistance unbalance"

To:

"Figure 145-22—PSE current unbalance verification circuit"

2. *Change figure 145-31 as follows:*

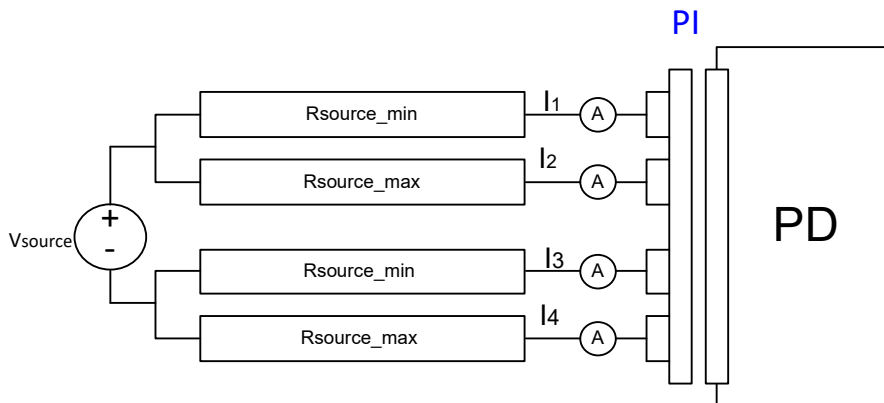

3. *Change the title of Figure 145-31 from:*

"Figure 145-31—Icon-2P_unb and lunbalance evaluation model"

To:

"Figure 145-31—PD current unbalance verification circuit"

5. *Delete Note 1* ("OTE 1—Rsource includes the connector resistance at the PD PI, for which the maximum recommended value is 20 mΩ per contact.)

6. *Make the following changes to NOTE 2:*

NOTE 2—The pairset current limits [requirement also holds](#) ~~should also be met~~ when Rsource_max and Rsource_min are swapped between pairs of the same polarity.

7. Change the following text in page 206 line 24 as follows:

Single-signature PDs shall not exceed $I_{Unbalance-2P}$ for longer than $TCUT_{min}$ and 5 % duty cycle, and shall not exceed $I_{Peak-2P-unb}$, as defined in Equation (145–12) on any pair when PD PI pairs of the same polarity are connected to any voltage in the range of $V_{Port_PSE-2P_{min+0.31}}$ to V_{Port_PSE-2P} through two common mode resistances, R_{source_min} and R_{source_max} , as defined in Equation (145–27) and shown in Figure 145–31.

Dual-signature PDs shall not exceed I_{Con_PD-2P} , as defined in Equation (145–28), for longer than $TCUT-2P_{min}$ and 5 % duty cycle, as defined in Table 145–16, and shall not exceed I_{Peak_PD-2P} , as defined in Equation (145–29), on any pair when PD PI pairs of the same polarity are connected to any voltage in the range of $V_{Port_PSE-2P_{min+0.31}}$ to V_{Port_PSE-2P} through two common mode resistances, R_{source_min} and R_{source_max} , as defined in Equation (145–27) and shown in Figure 145–31.