

100 Gb/s SMF PMD Specifications and Objectives Proposal

IEEE 802.3 50 Gb/s Ethernet Over a Single Lane Study
Group

IEEE 802.3 Next Generation 100 Gb/s Ethernet & 200 Gb/s
Ethernet Study Group

802.3 Interim Session

Atlanta, Georgia

20-22 January 2016

Chris Cole



50G SerDes ASIC 100 Gb/s PMD Alternatives

- Alt. 1: 50 Gb/s end-to-end
(replicates 10 Gb/s and 25 Gb/s end-to-end ecosystem)

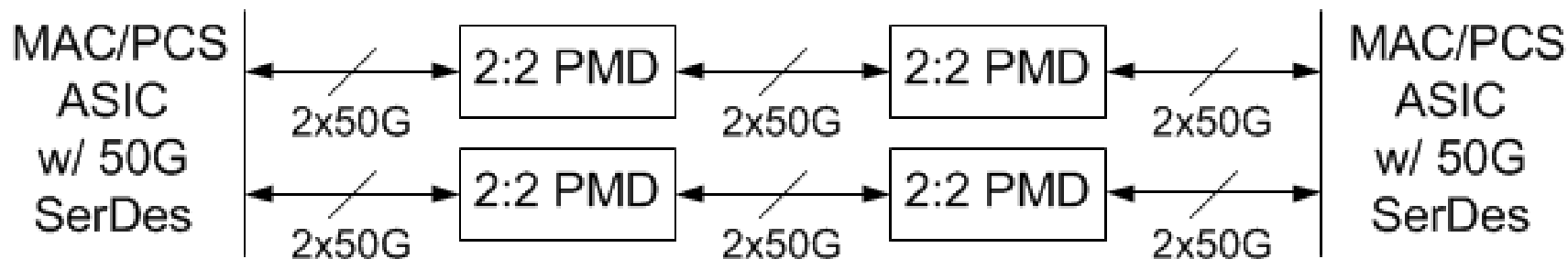

- Single end-to-end rate paradigm dominates volume shipment at previous rates
- Assumed to be the dominant 50 Gb/s volume paradigm

50G SerDes ASIC 100 Gb/s PMD Alternatives

- Alt. 2: 2:4 DeMux
(could be backwards interoperable)

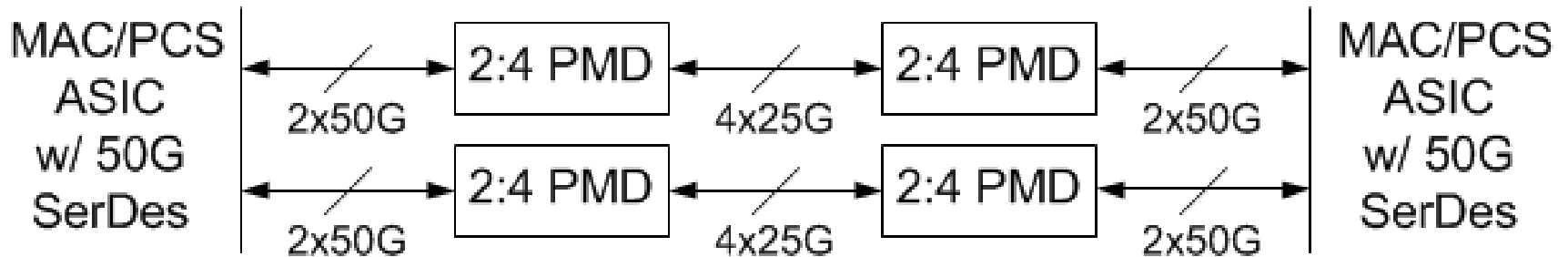

- Alt. 3: 2:1 Mux
(could be forwards interoperable)

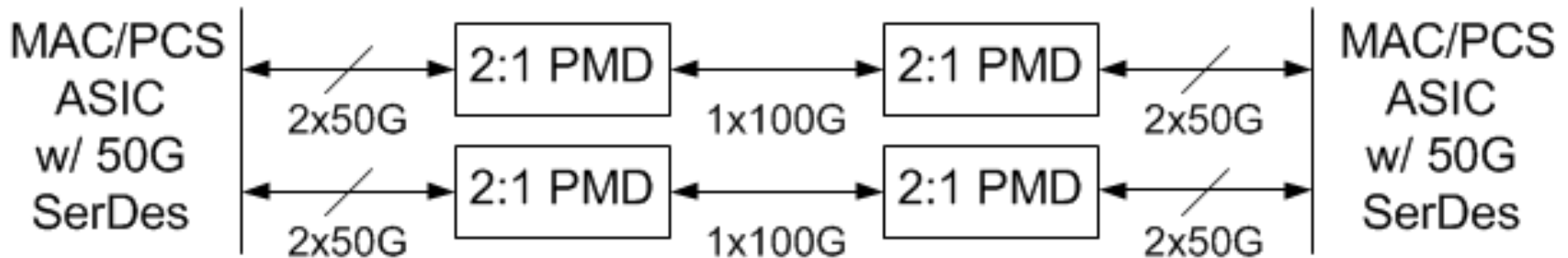

50G SerDes ASIC 100 Gb/s PMD Alternatives

- Alt. 4: 200 Gb/s replaces 100 Gb/s
(i.e. 100 Gb/s support not important)

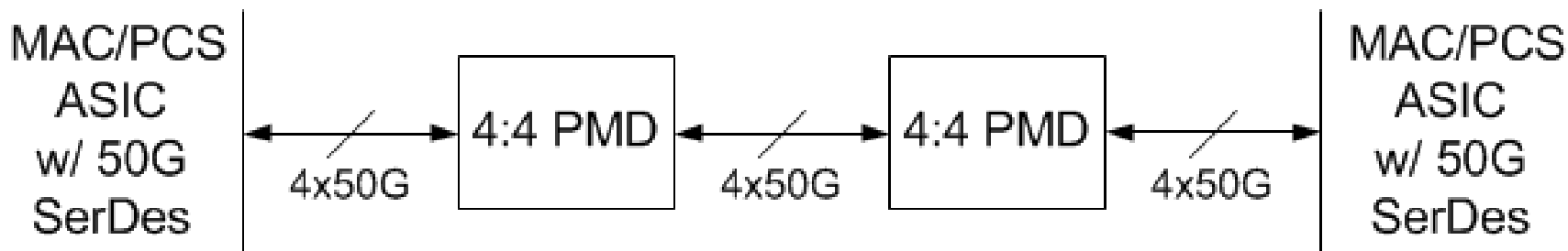

- Alt.5: 50G SerDes in 25G mode
(strands 50% of ASIC and SerDes bandwidth)

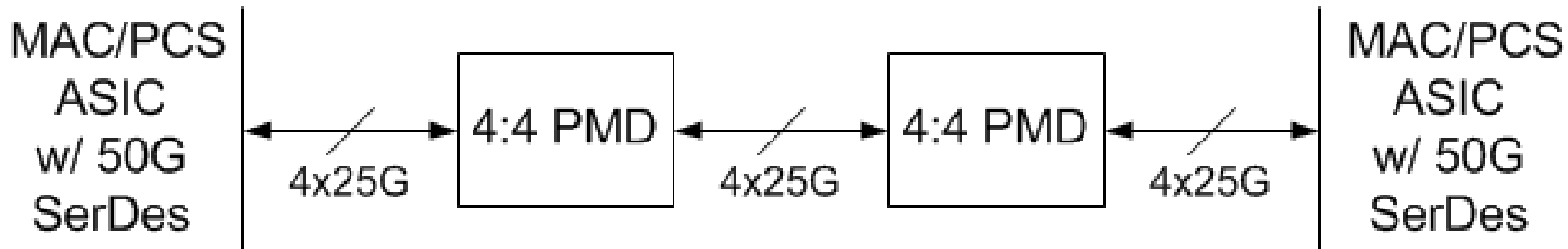

100 Gb/s SMF PMD Example Block Diagram

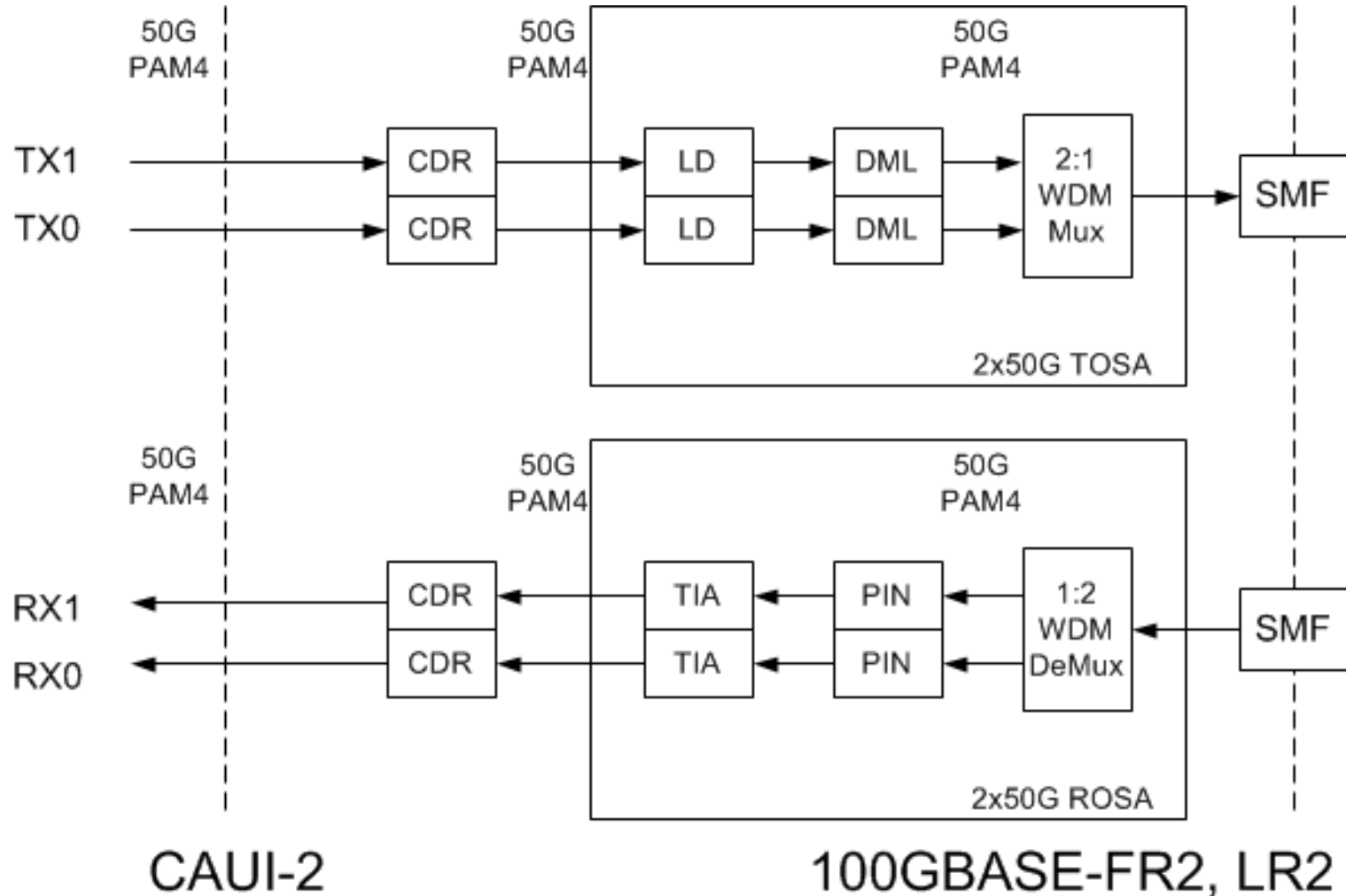

Transmit Characteristics

Description (PAM4)	100GBASE-FR2	100GBASE-LR2	Unit
Reach	2	10	km
Signaling Rate, each lane	26.5625	26.5625	GBd
Operating BER	2.0E-04	2.0E-04	
Total average launch power (max)	6.2	7.6	dBm
OMA _{outer} , each lane (max)	3.0	4.4	dBm
OMA _{outer} , each lane (min)	-1.8	-0.6	dBm
Diff. in launch power between any two lanes (OMA _{outer}) (max)	3.5	3.5	dB
Launch Power in OMA _{outer} minus TDP, each lane (min)	-2.8	-1.6	dBm
Transmitter and dispersion penalty, (TDP) each lane (max)	2.3	2.5	dB
Extinction ratio (ER) (min)	4.5	4.5	dB
RIN OMA (max)	TBD	TBD	dB/Hz

Receive Characteristics

Description (PAM4)	100GBASE-FR2	100GBASE-LR2	Unit
Signaling Rate, each lane	26.5625	26.5625	GBd
Operating BER	2.0E-04	2.0E-04	
Receiver reflectance (max)	TBD	TBD	dB
Receiver Sensitivity (OMA_{inner}), each lane (max)	-11.6	-12.7	dBm
Stressed receiver sensitivity (OMA_{inner}), each lane (max)	TBD	TBD	dBm
Conditions of stressed receiver sensitivity test	TBD	TBD	

Illustrative Link Power Budgets

Description (PAM4)	100GBASE-FR2	100GBASE-LR2	Unit
Power Budget (for maximum TDP)	11.1	13.6	dB
Operating Distance	2	10	km
Channel Insertion Loss	4.0	6.3	dB
Maximum Discrete Reflectance	TBD	TBD	dB
Allocation for Penalties* (for maximum TDP)	2.3	2.5	dB
Allocation for Modulation Penalties	4.8	4.8	dB

* Includes MPI penalty

WDM Lane Assignments

100GBASE CWDM Lane	Center Wavelength nm	Wavelength Range nm
L0	1271	1264.5 to 1277.5
L1	1311	1304.5 to 1317.5

Optical Margin

Description (PAM4)	100GBASE-FR2	100GBASE-LR2	Unit
Receiver Sensitivity (OMA_{inner}), each lane, pre-DeMux (max)	-11.6	-12.7	dBm
DeMux Loss	1.0	1.0	dB
Cross-talk penalty	0.3	0.3	dB
Receiver Sensitivity (OMA_{inner}), each lane, post-DeMux (max)	-12.9	-14.0	dBm
Receiver Sensitivity (OMA_{inner}) single lane (typical measured)	-17.0	-17.0	dBm
Optical Margin	4.1	3.0	dB

Preferred 100 Gb/s Objectives

- Support a MAC data rate of 100 Gb/s
- Support a BER of better than or equal to 10^{-13} at the MAC/PLS service interface (or the frame loss ratio equivalent)
- Support full-duplex operation only
- Preserve the Ethernet frame format utilizing the Ethernet MAC
- Preserve minimum and maximum FrameSize of current Ethernet standard
- Provide appropriate support for OTN
- Provide physical layer specifications which support 100 Gb/s operation over:
 - At least 2 km of SMF
 - At least 10 km of SMF
- Specify optional Energy Efficient Ethernet (EEE) capability
- Support optional Attachment Unit Interfaces for chip-to-chip and chip-to-module applications

100 Gb/s SMF PMD Alternatives

- Existing 4x25G SMF PMDs
 - 100GBASE-ER4
 - 100GBASE-LR4
 - 100G CWDM4 (CLR4 is variant w/o FEC)
 - 100G PSM4
 - Multiple “lite” and “extended” variants of the above
- 2x50G SMF PMD Alternatives
 - 100GBASE-LR2 (CWDM2; O band)
 - 100GBASE-FR2 (CWDM2; O band)
 - 100GBASE-DR2 (CWDM2; O & C band)
 - 100GBASE-DR2 (PSM2)
- 1x100G SMF PMD Alternatives
 - 100GBASE-DR
- Task Force decisions will require lengthy debate

Proposed (Realistic) 100 Gb/s Objectives

- Support a MAC data rate of 100 Gb/s
- Support a BER of better than or equal to 10^{-13} at the MAC/PLS service interface (or the frame loss ratio equivalent)
- Support full-duplex operation only
- Preserve the Ethernet frame format utilizing the Ethernet MAC
- Preserve minimum and maximum FrameSize of current Ethernet standard
- Provide appropriate support for OTN
- Provide physical layer specifications which support 100 Gb/s operation over:
 - At least 100m of MMF*
- Specify optional Energy Efficient Ethernet (EEE) capability
- Support optional Attachment Unit Interfaces for chip-to-chip and chip-to-module applications

*Discussed in king_50GE_NGOATH_01_0116

Recommendations

- Form new 50 Gb/s and Next Generation 100 Gb/s Ethernet Task Force
- Adopt Proposed 100 Gb/s Objectives (page 13) for the 50 Gb/s and Next Generation 100 Gb/s Ethernet Task Force
- Solve in one Task Force common 50 Gb/s single lane and 100 Gb/s two lane problems, like backwards interoperability with 2x25G and 4x25G ASIC I/O, respectively.

Appendix: Proposed 50, 100, 200G Objectives

- 50 Gb/s & Next Generation 100 Gb/s Ethernet Task Force
 - 50G MAC/PCS
 - LAUI w/ FEC
 - 50GBASE-SR
 - 50GBASE-FR, -LR
 - *50GBASE-KR, -CR **
 - CAUI-2 w/ FEC
 - 100GBASE-SR2
 - *100GBASE-KR2, -CR2 **
 - 200GBASE-SR4
 - *200GBASE-KR4, -CR4 **
- 200 Gb/s & 400 Gb/s Ethernet Task Force
 - 200G MAC/PCS
 - CCAUI-4 w/ FEC
 - 200GBASE-FR4, LR4

*Backplane and copper cable maybe need to be deferred to future project.

100 Gb/s Specs and Objectives

Thank you