



# Considerations for 100G FEC and Framing for 80km over a DWDM system

Ilya Lyubomirsky, Benjamin Smith, Jamal Riani, Sudeep Bhoja, Inphi Corp.  
Gary Nicholl, Mark Nowell, Fernando Villarruel, Cisco Systems, Inc.

Sept. 10, 2018

# Supporters

- Rich Baca, Microsoft
- Paul Brooks, Viavi Solutions
- James Chien, ZTE
- Steve Trowbridge, Nokia

# Goals for 100G FEC and Framing

- Enable low power FEC for pluggable modules with sufficient coding gain for 80km reach
- Leverage coherent technology developments in OIF and/or ITU-T

# Three Options Considered

- Option 1: Leverage OIF 400ZR standard
- Option 2: Develop a new framing format
- Option 3: Leverage ITU-T G.709.2 100G standard

# Option 1: Adapt OIF 400ZR FEC+Framing to 100G

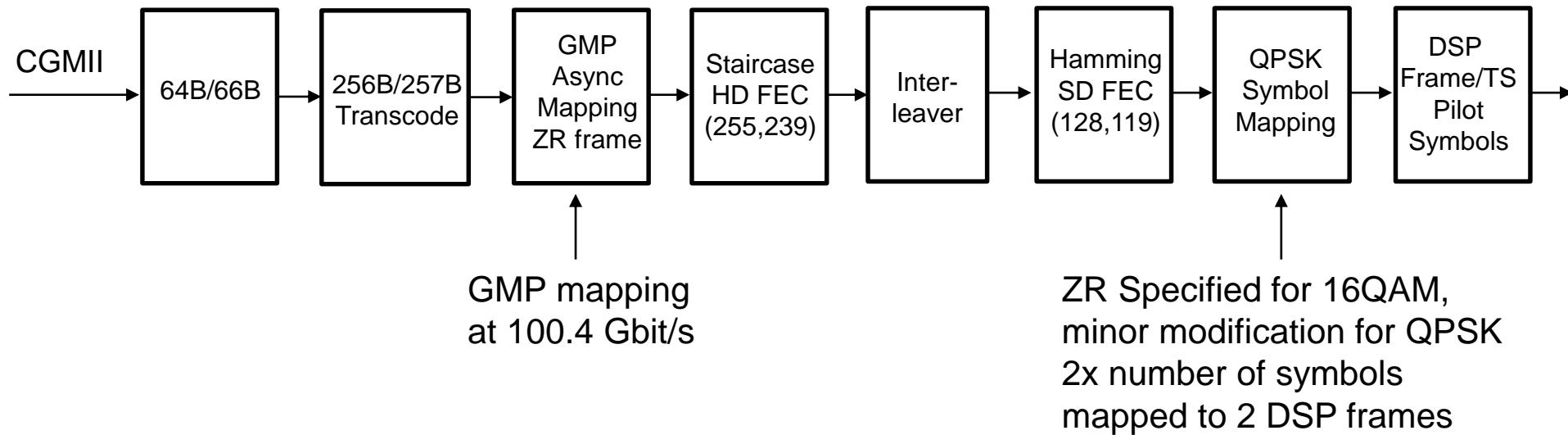

Propose to re-use the same OIF ZR framing format.

Optional to implement Hamming decoder as hard decision decoder (not using LLR soft information):

- Saves ~ 10-15% power
- Coding gain reduced to 9.9 dB

## Option 2: Adapt only Staircase FEC for 100G

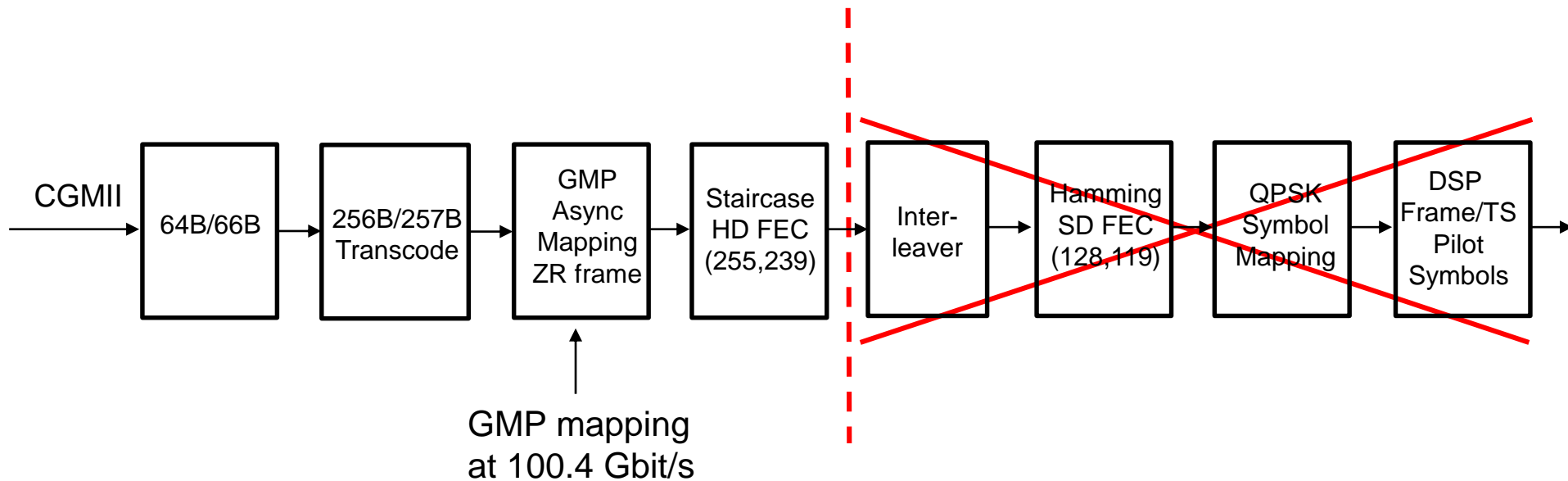

Would need to develop new DSP framing format, e.g. use simple differential encoding (DQPSK) to eliminate pilot overhead (Baud Rate ~ 26.8 Gbaud); SC FEC NCG = 9.4 dB, with additional ~ 0.8 dB loss if using a DQPSK differential decoding

# Option 3: ITU-T G.709.2 OTU4 Long Reach

OTU4 Frame

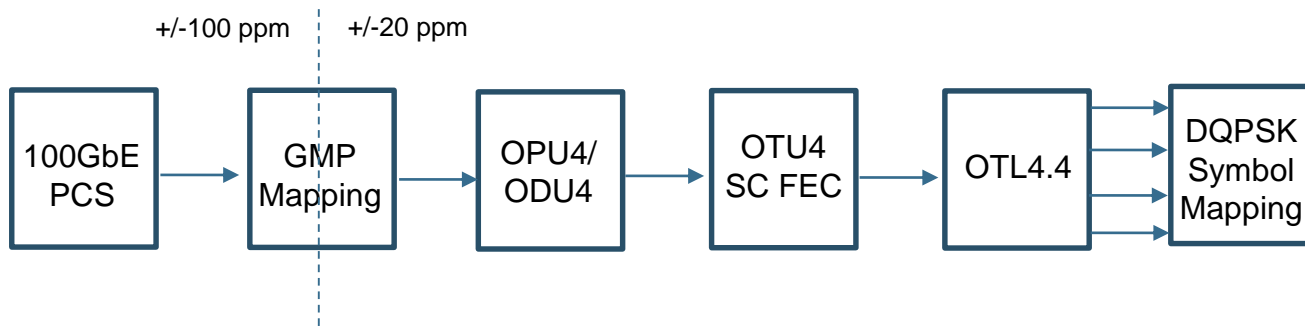
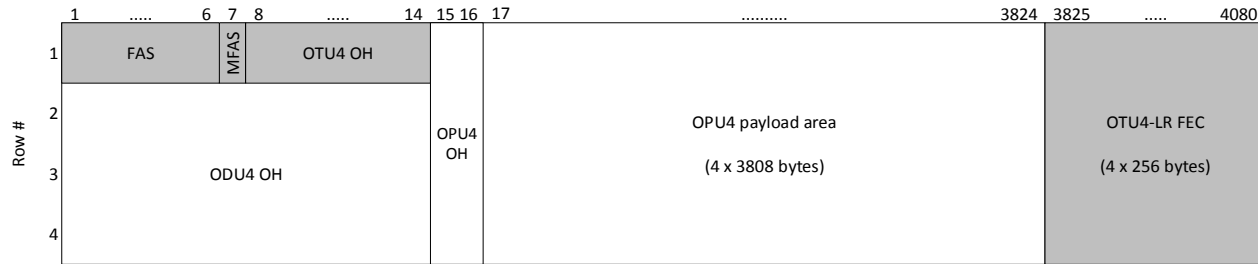

Frame format includes OTN overhead, baud rate = 28 Gbaud.  
SC FEC NCG = 9.4 dB, with additional ~ 0.8 dB loss for DQPSK differential decoding



# 100G FEC+Framing Options Comparison Table

	Option 1	Option 2	Option 3
Standard	OIF 400ZR	None	ITU-T G709.2
Baud Rate (Gbaud)	29.9	26.8	28
FEC NCG (dB)	10.34	9.4	9.4
Pre-FEC BER	1.25e-2	4.5e-3	4.5e-3
Burst Tolerance (bits)	1000	400	400
Modulation	QPSK	DQPSK	DQPSK
Differential Decoding Loss (dB)	0	~ 0.8	~ 0.8
Line Clock Accuracy	+/- 100 ppm	+/- 100 ppm	+/- 20 ppm
Relative Power to 400G ZR	~ 1/4	~ 1/4	~ 1/4
Latency	< 16 $\mu$ s	< 16 $\mu$ s	< 16 $\mu$ s
Leverage IP	Yes	Partially	Yes
Synergy other 100G coherent standards	-	-	OpenRoadm, Cablelabs



# Conclusions

- Option 1 would leverage OIF 400ZR standard for 100G, giving maximum similarity with 400G ZR
- Option 3 would leverage ITU-T G.709.2 100G standard, already implemented in current generation of coherent DSP ASICs
- Option 2 maybe the most “lightweight” in terms of overhead but requires development of a new framing format