

# PoDL for NGAUTO: Demonstration of Feasibility

Andy Gardner

Linear Technology Corp

# Overview

- For NGAUTO, media other than balanced twisted-pair may be used
- Clause 104 currently defines PoDL for use with 100BASE-T1 and 1000BASE-T1 on single balanced twisted-pair media
  - Link segment definitions in Clause 104 do not rely on the fact that it is a balanced twisted-pair
  - Any two-conductor media meeting the loop resistance would suffice
- Technical feasibility of PoDL with NGAUTO on other than UTP is shown

# NGAUTO PoDL Test Fixture

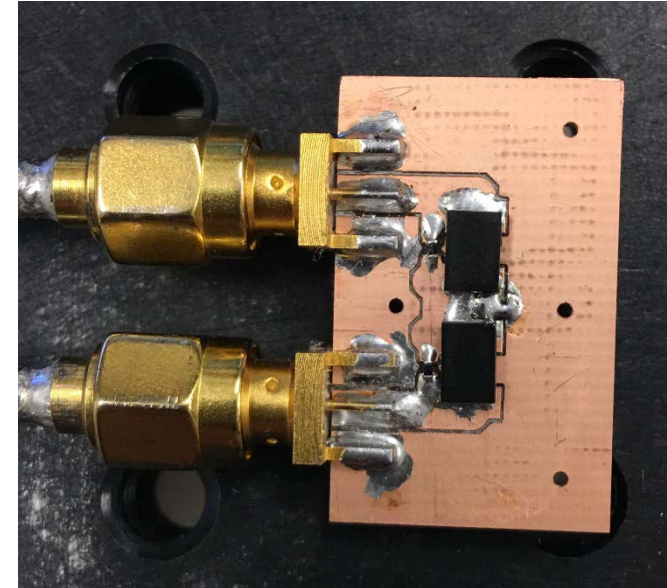
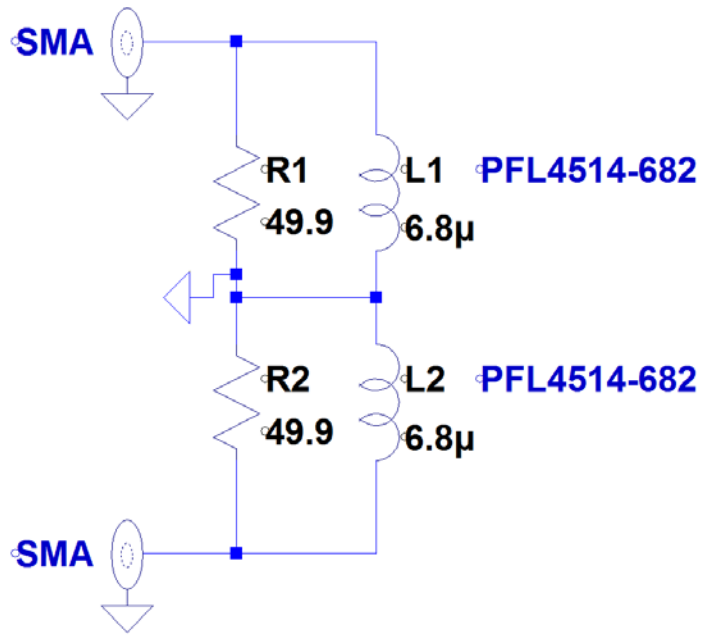

- Used off-the-shelf inductors from an established magnetics vendor
- No attempt was made to add common mode impedance in series with inductors L1/L2 in order to limit mode conversion resulting from mismatch
- Inductors have  $\sim 0.9$ A ampacity which is limited by self-heating resulting from  $0.4 \Omega$  DCR (typ)

# NGAUTO PoDL Test Fixture Mode Conversion Loss

- Low frequency mode conversion is a function of inductor OCL matching
- -46dB sdcc11 at 1MHz is consistent with 1.1% mismatch between the two inductors used in the test fixture
- $\pm 20\%$  inductor tolerance will yield -48dB sdc11 at 60MHz
- A PoDL CMC could be used to suppress low frequency sdc11 for mismatched inductors at increased solution cost and complexity

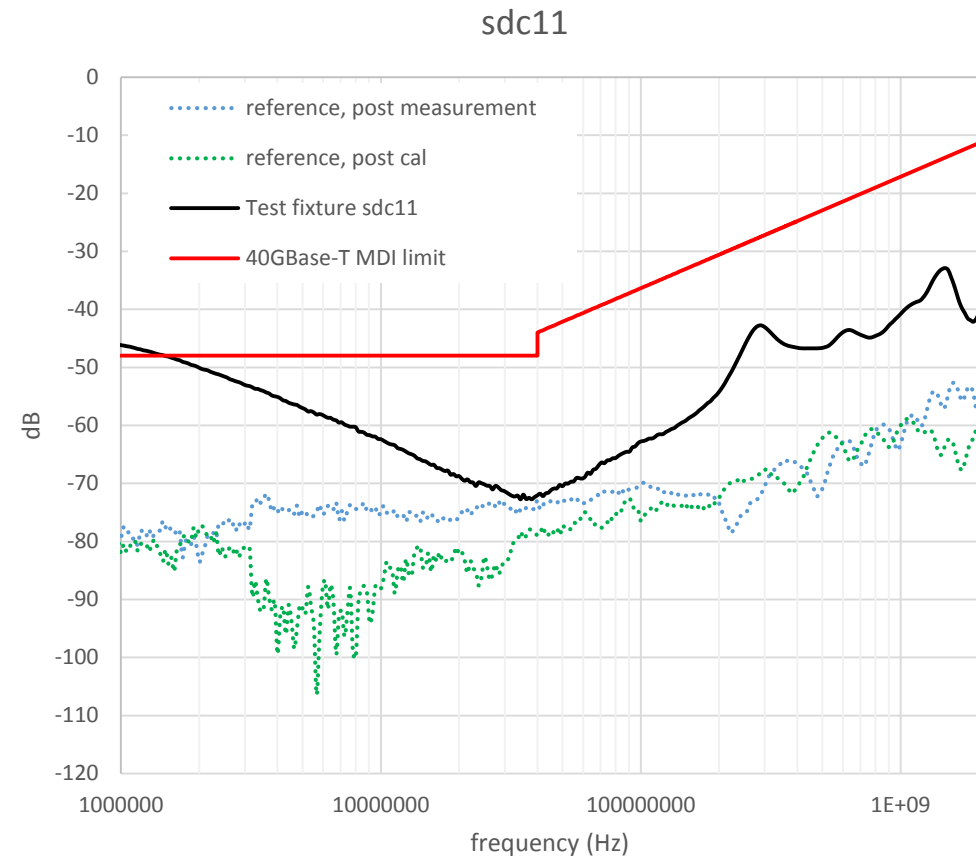

# NGAUTO PoDL Test Fixture MDI Return Loss

- Low frequency sdd11 is limited by inductor's  $6.8\mu\text{H}$  OCL.
- High frequency sdd11 is limited by inductors self-resonant frequency
- $6.8\mu\text{H}$  OCL was selected to meet the 40GBase-T transmitter droop specification with 20% margin instead of the MDI sdd11 limit at 1MHz

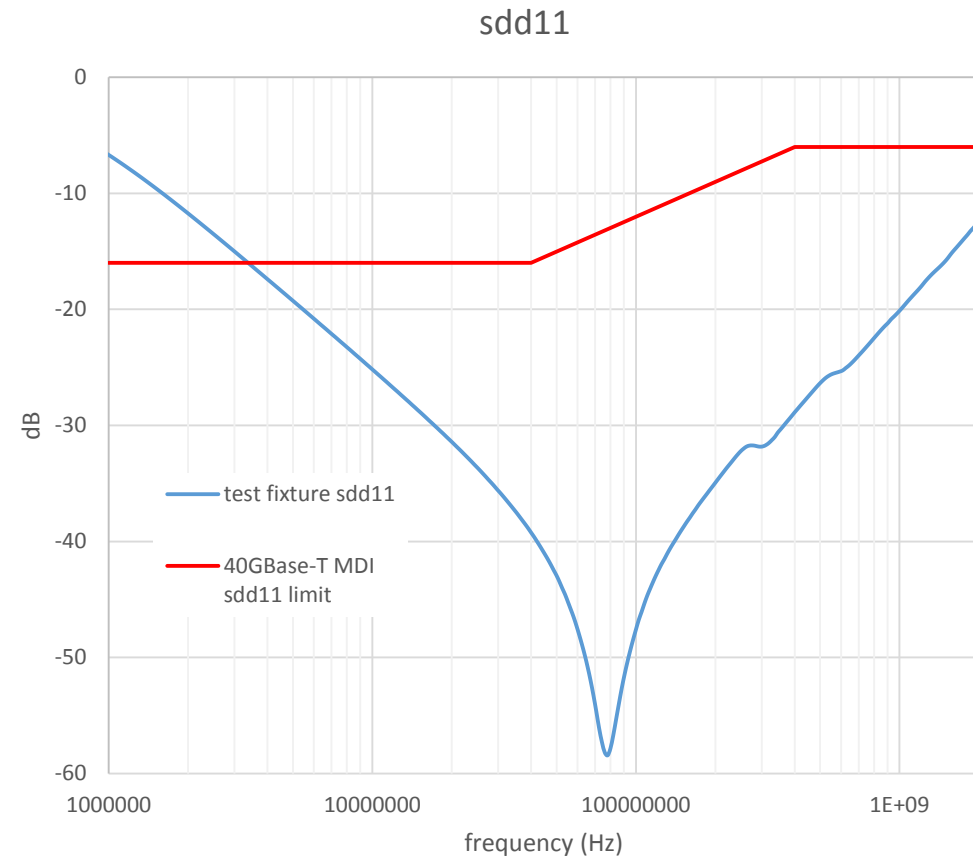

# Conclusions

- PoDL for UTP is challenging because of the simultaneous MDI return loss, MDI mode conversion loss, and application ampacity requirements
- PoDL for NGAUTO STP or FTP is feasible for a simple power coupling network if the MDI sdc11 low frequency limit can be relaxed from that in 40GBase-T to -48dB at 60MHz
  - Otherwise a PoDL CMC or well matched inductors are required
- If the 40GBase-T transmitter droop requirement is the only constraint on PoDL inductor OCL, off-the-shelf 6.8uH inductors with 0.9A ampacity can meet the 40GBase-T MDI sdd11 limit above 4MHz

# Proposed Objective

- Support optional Clause 104 power over data lines on appropriate media