802.3bz Link Segment Considerations Waikola, HI July 2015

**Chris DiMinico
MC Communications/Panduit
cdiminico@ieee.org**

Summary

- **Development of baseline for 802.3bz Link Segments.**
 - **Within link segment – e.g., IL, RL, etc.**
 - **Between link segments – Alien**
- **Proposal for Link Segment specifications in Clause 126.**

802.3bz Objectives

Next Generation Enterprise Access BASE-T PHY Objectives

- Support full duplex operation only
- Preserve the 802.3 / Ethernet frame format utilizing the 802.3 MAC
- Preserve minimum and maximum Frame Size of current 802.3 standard
- Support Auto-Negotiation (Clause 28)
- Support optional Energy Efficient Ethernet (Clause 78)
- Support local area networks using point-to-point links over structured cabling topologies
- Do not preclude meeting FCC and CISPR EMC requirements
- Support PoE (Clause 33)
 - including amendments made by 802.3bt “DTE Power via MDI over 4-Pair Task Force”
- Support MAC data rates of 2.5 Gb/s and 5 Gb/s
- Support a BER better than or equal to 10^{-12} at the MAC/PLS service interface (or the frame loss ratio equivalent)
- Select copper media from ISO/IEC 11801:2002, with any appropriate augmentation to be developed through work of 802.3 in conjunction with ISO/IEC JTC 1/SC 25/WG3 and TIA TR42
- Define a 2.5 Gb/s PHY for operation over
 - Up to at least 100m on four-pair Class D (Cat5e) balanced copper cabling on defined use cases and deployment configurations
- Define a 5 Gb/s PHY for operation over
 - Up to at least 100m on four-pair Class E (Cat6) balanced copper cabling on defined use cases and deployment configurations
 - Up to 100m on four-pair Class D (Cat5e) balanced copper cabling on defined use cases and deployment configurations

IEEE 802.3 NGEABT Objectives approved by IEEE 802.3, March 12, 2015 Berlin, DE

1

IEEE Cabling Topology

•IEEE 802.3 Twisted-Pair Link Segment

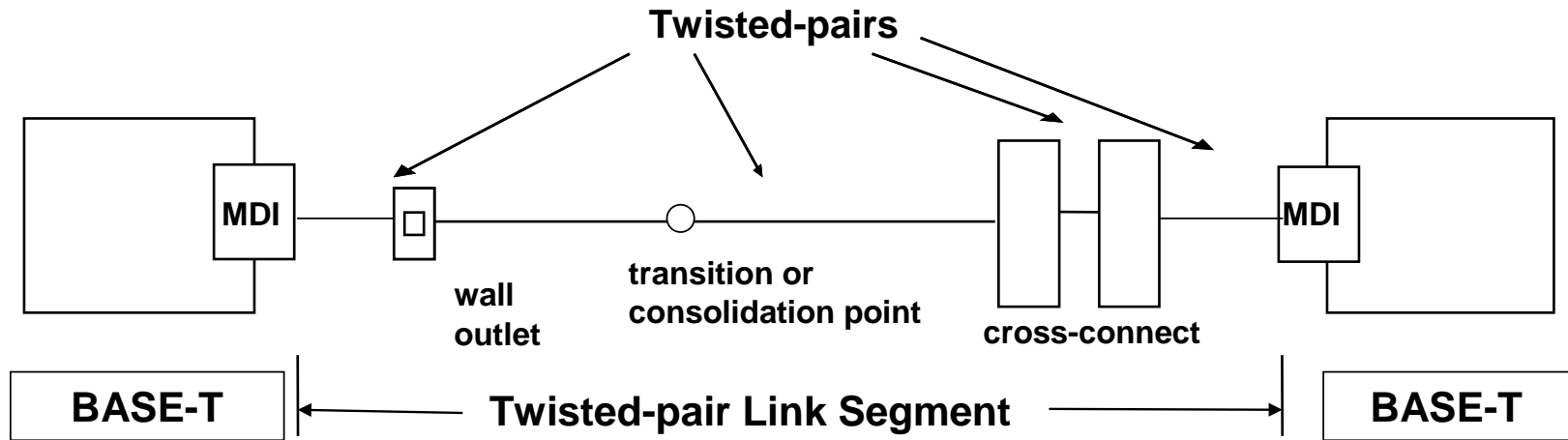

10BASE-T/100BASE-T/1000BASE-T/10GBASE-T

Channel and Permanent Link

- Channel test configuration to emulate IEEE link segments enabling IEEE to reference cabling standards .

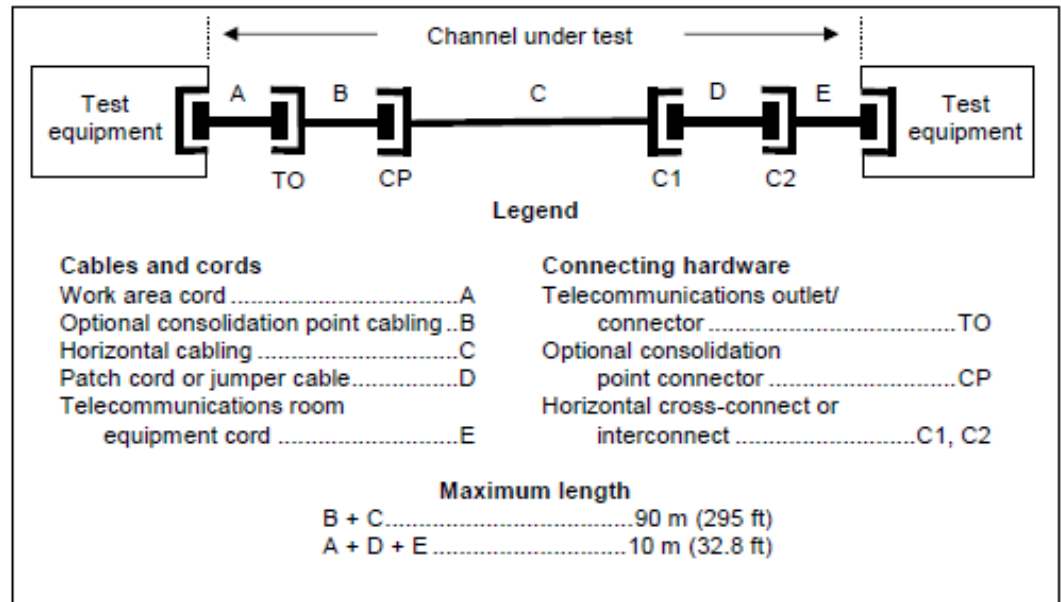

- Channel and permanent link transmission requirements developed from cables, cords, and connecting hardware transmission requirements

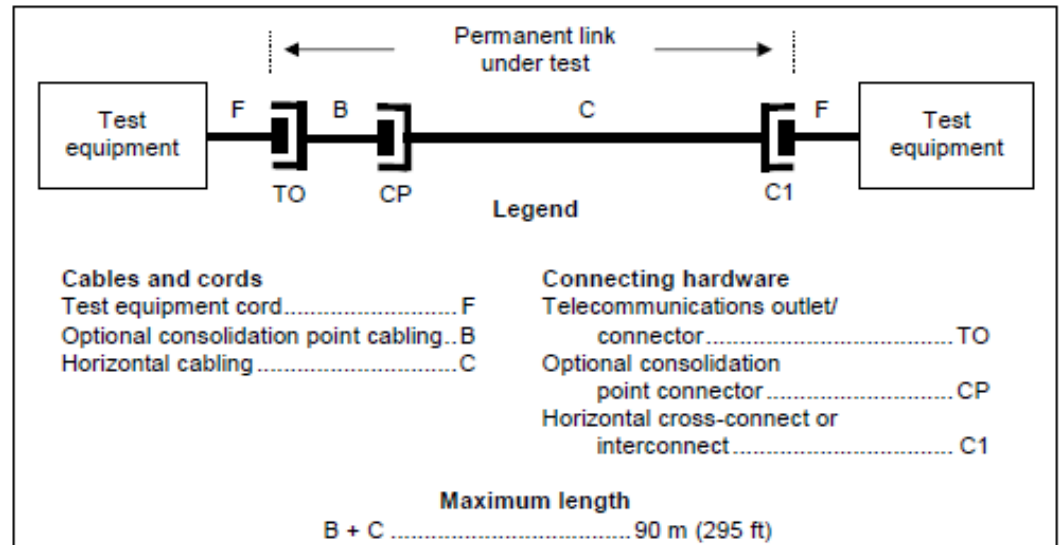

Deployment configuration objectives

- Define a 2.5 Gb/s PHY for operation over
 - Up to at least 100m on four-pair Class D (Cat5e) balanced copper cabling on defined use cases and deployment configurations
 - Define a 5 Gb/s PHY for operation over
 - Up to at least 100m on Class E (Cat6) balanced copper cabling on defined use cases and deployment configurations
 - Up to 100m on Class D (Cat5e) balanced copper cabling on defined use cases and deployment configurations
- 1) Use cases and deployment configurations for 2.5 Gb/s PHY for operation over
 - Up to at least 100m on four-pair Class D (Cat5e) balanced copper cabling
 - 2) Use cases and deployment configurations for a 5 Gb/s PHY for operation over
 - Up to at least 100m on Class E (Cat6) balanced copper cabling
 - 3) Use cases and deployment configurations for a 5 Gb/s PHY for operation over
 - Up to 100m on Class D (Cat5e) balanced copper cabling
- Use case based deployment configurations not required for PHYs demonstrating operation over “worse case” cabling configurations (4 connector with cable (6x1) tie wrapped every 8”).

126.7 Link segment characteristics

2.5G/5GBASE-T is designed to operate over ISO/IEC 11801 Class D 4-pair balanced cabling that meets the additional requirements specified in this subclause. Each of the 2.5GBASE-T four pairs supports an effective data rate of 626 Mb/s in each direction simultaneously. Each of the 5GBASE-T four pairs supports an effective data rate of 1626 Mb/s in each direction simultaneously. The term “link segment” used in this clause refers to four twisted-pairs operating in full duplex. Specifications for a link segment apply equally to each of the four twisted-pairs. All implementations of the balanced cabling link segment specification shall be compatible at the MDI. It is recommended that the guidelines in TIA TSB-XX, ISO/IEC TR X, ANSI/TIA-568-C.2, and ISO/IEC 11801:2002/Amendment 1 be considered before the installation of 2.5/5GBASE-T equipment for any cabling system.

126.7.1 Cabling system characteristics

2.5/5GBASE-T requires 4 pair Class D cabling with a nominal impedance of 100 Ω , as specified in ISO/IEC 11801:2002. Operation on other classes of cabling may be supported if the link segment meets the requirements of 126.7.

Additionally:

- a) 2.5GBASE-T is an ISO/IEC 11801-2002 Class D application, with additional installation requirements and transmission parameters specified in this clause.
- b) 5GBASE-T is an ISO/IEC 11801-2002 Class D application, with additional installation requirements and transmission parameters specified in this clause, including extended frequency performance beyond that specified for Class D Channels.
- c) The use of shielding is outside the scope of this specification.

Category 5e and Category 6 Cabling

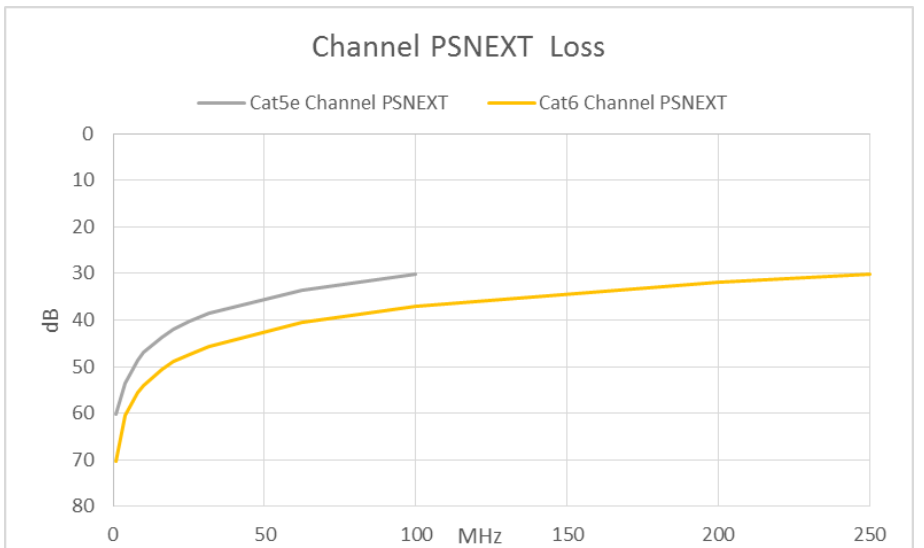
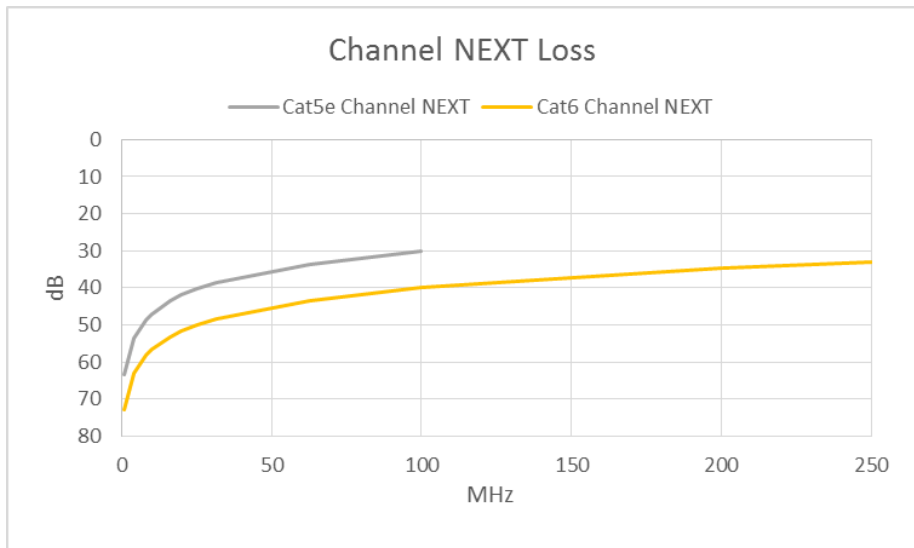
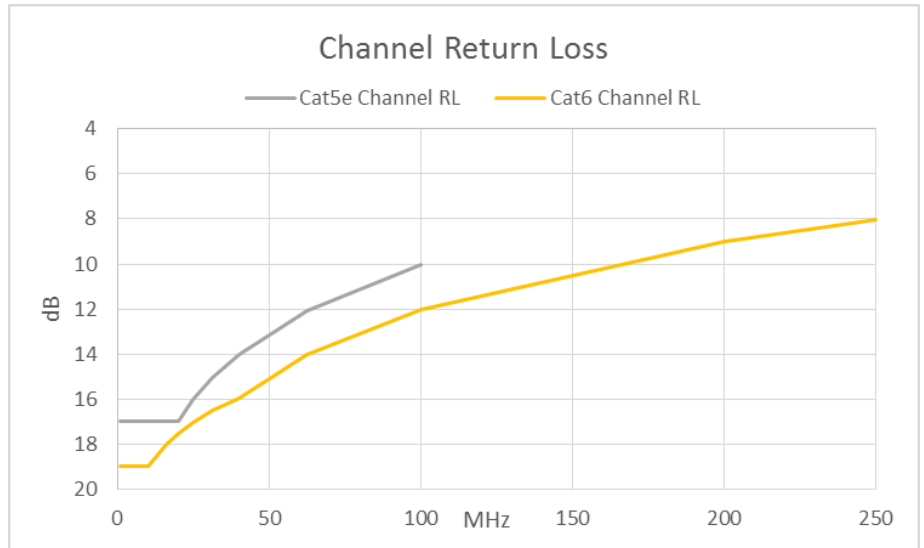
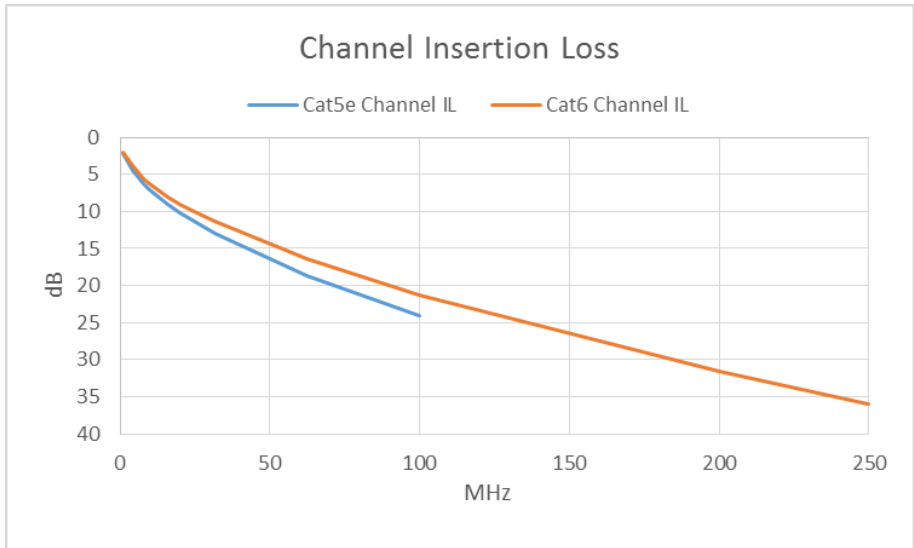

Category 5e and Category 6 Cabling

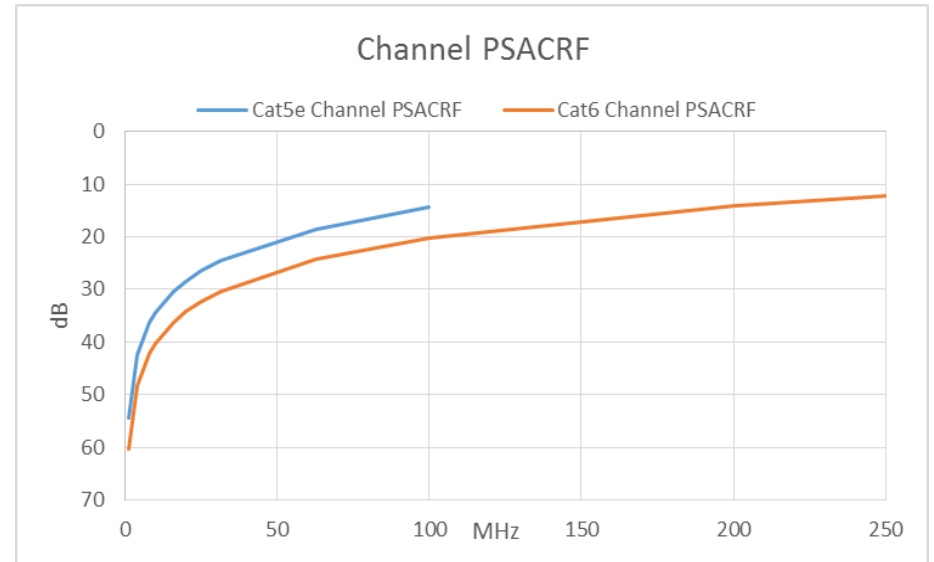
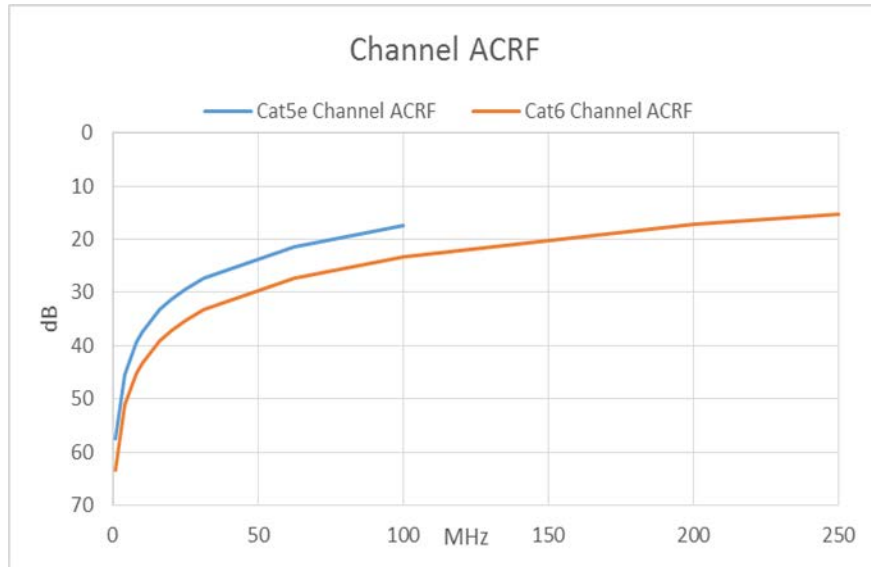

126.7 Link Segment Specification

- Define a 2.5 Gb/s PHY for operation over
 - Up to at least 100m on four-pair Class D (Cat5e) balanced copper cabling on defined use cases and deployment configurations
 - Link Segment option
 - ✓ Category 5e Cabling
- Define a 5 Gb/s PHY for operation over
 - Up to at least 100m on Class E (Cat6) balanced copper cabling on defined use cases and deployment configurations
 - Up to 100m on Class D (Cat5e) balanced copper cabling on defined use cases and deployment configurations
 - Link Segment options
 - ✓ Category 5e cabling with appropriate augmentation
 - ✓ Category 6

126.7 Link Segment Specification Options

- **2.5/ 5 Gb/s PHY Link Segment**

- **Category 5e cabling with appropriate augmentation on defined use cases and deployment configurations**

- **2.5 Gb/s PHY Link Segment**

- **Category 5e cabling on defined use cases and deployment configurations**

- **5 Gb/s PHY Link Segment**

- **Category 6 on defined use cases and deployment configurations [satisfies up to 100m Class D (Cat5e) m(TBD)]**

Link Segment 2.5/5 Gb/s PHY considerations

Next Generation Enterprise BASE-T Access

Between 1G and 10G, There's Lots of Room for BASE-T PHYs

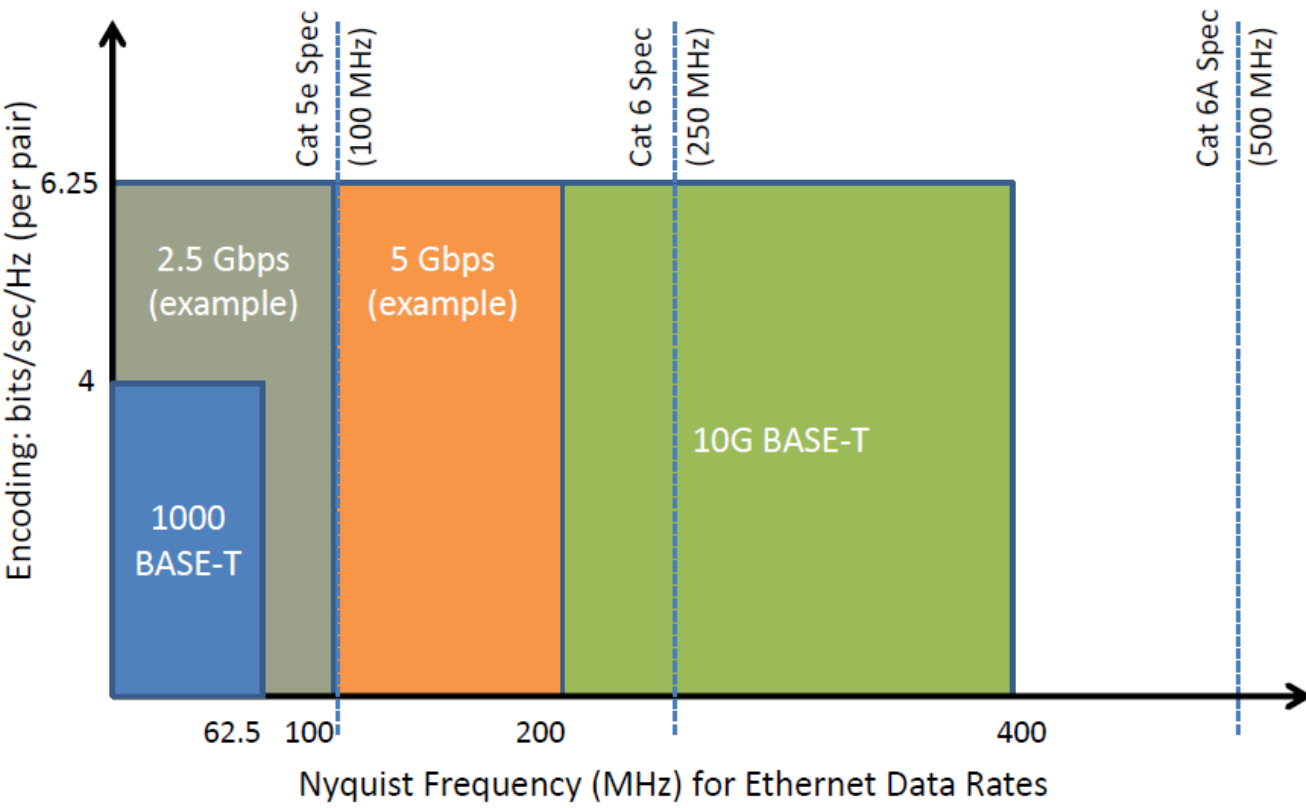

Link Segment 5 Gb/s PHY considerations

- 5 Gb/s PHY Link Segment BW > 200 MHz
 - Cat 6 - ~4 dB margin at 200 MHz from Cat5e extended to 250 MHz

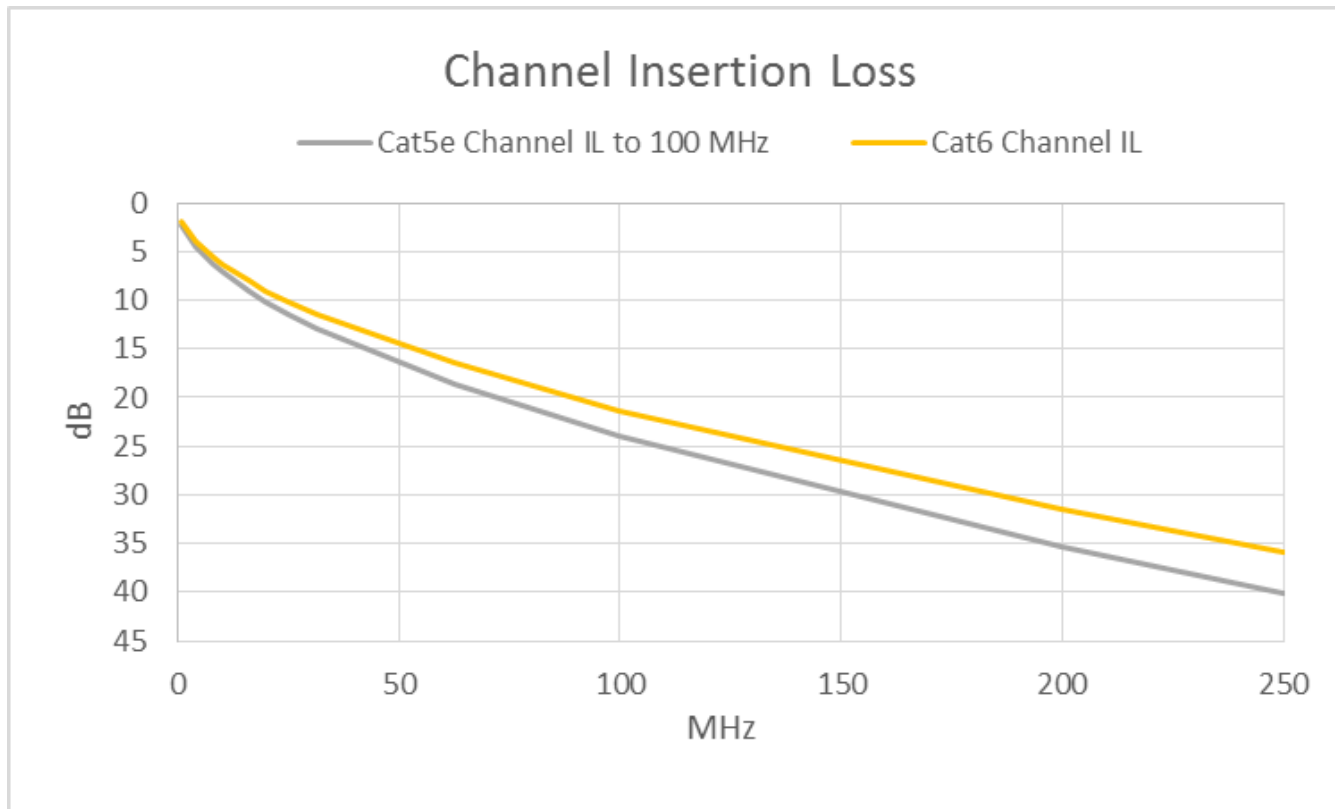

Proposal: Link Segment IL

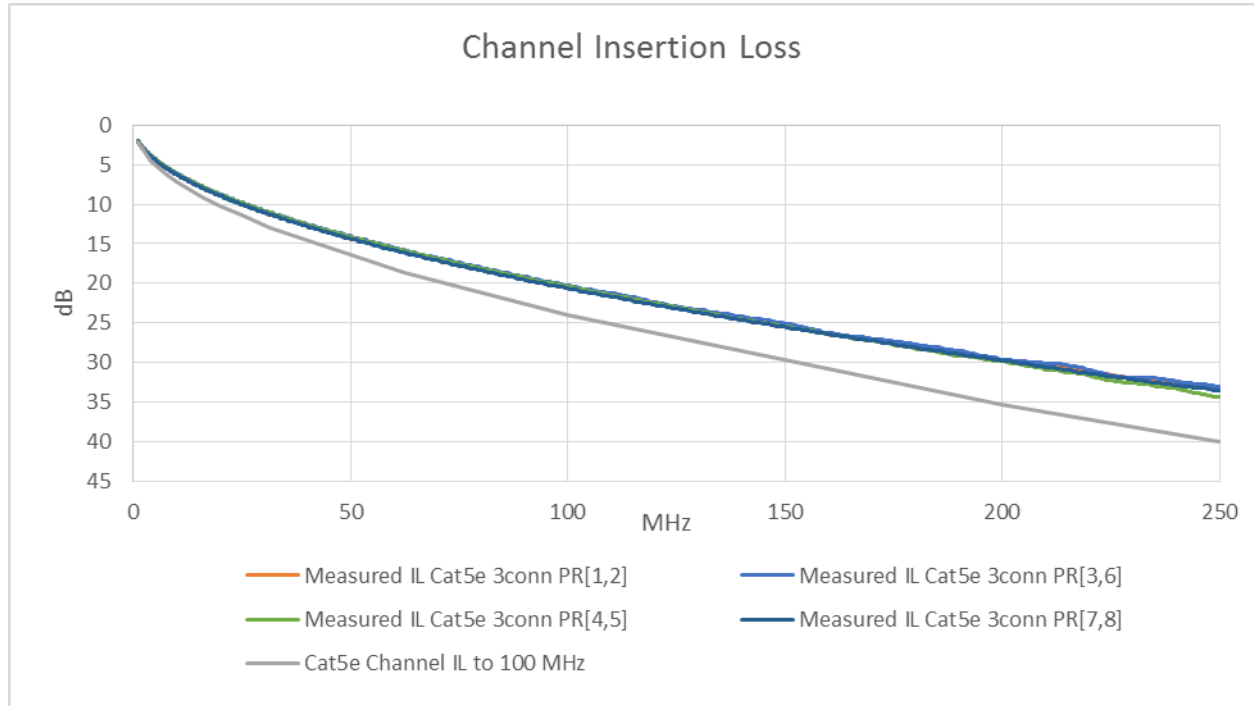

$$\text{Link Segment} = 1.02 * (1.967 * \text{SQRT}(f) + 0.023 * (f) + 0.05 / \text{SQRT}(f)) + 4 * 0.04 * \text{SQRT}(f) \quad 1 < f <= 250 \text{ MHz}$$

Proposal: Link Segment RL

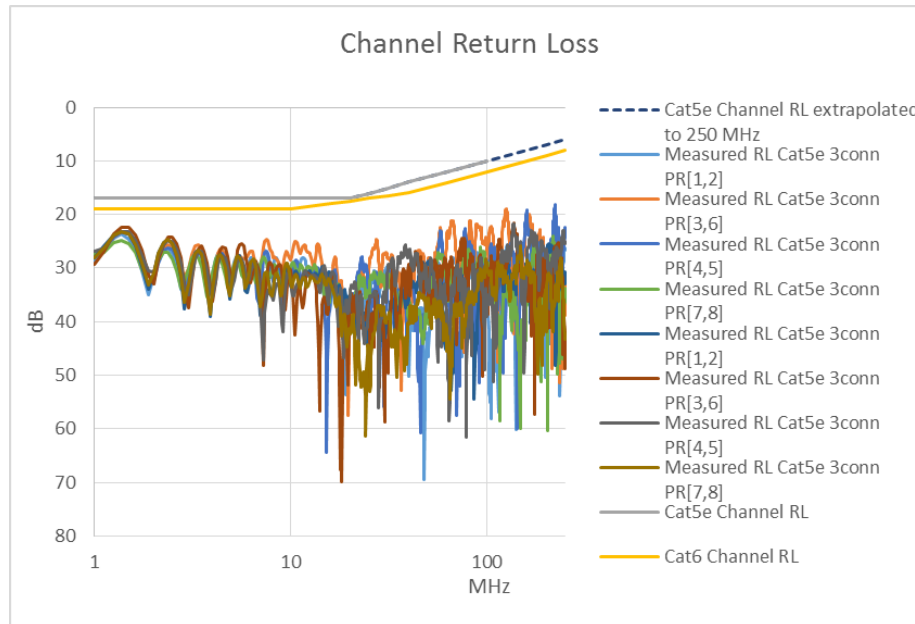

$$RL = -17 \quad 1 \leq f < 100 \text{ MHz}$$
$$17 - 10 \cdot \log(f/20) \quad 20 \leq f \leq 250 \text{ MHz}$$

*Please note: Validated with TR42 RL models
To be provided in update*

Proposal: Link Segment NEXT/PSNEXT

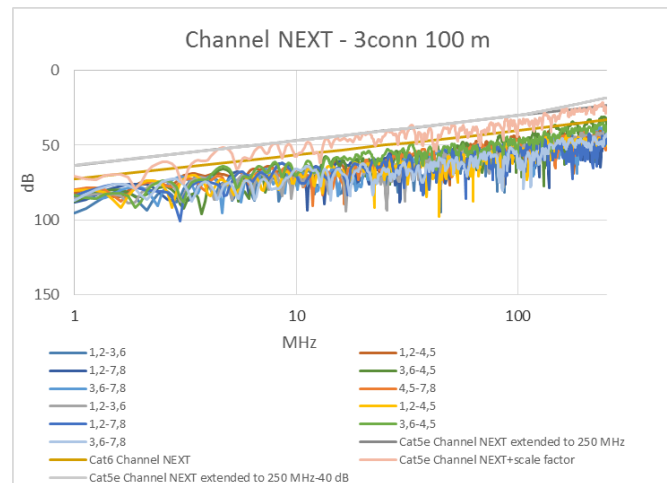
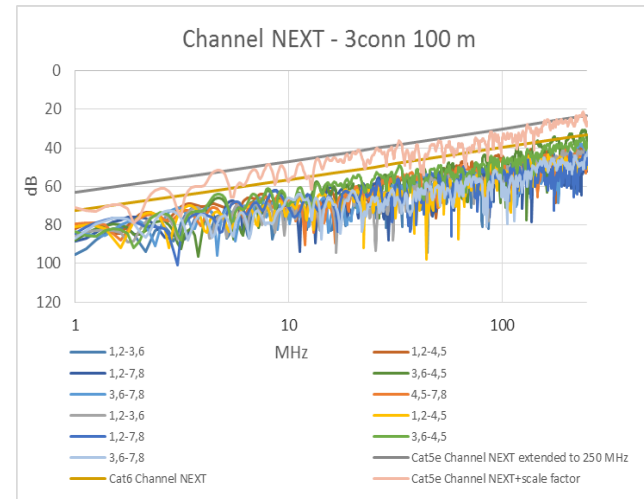
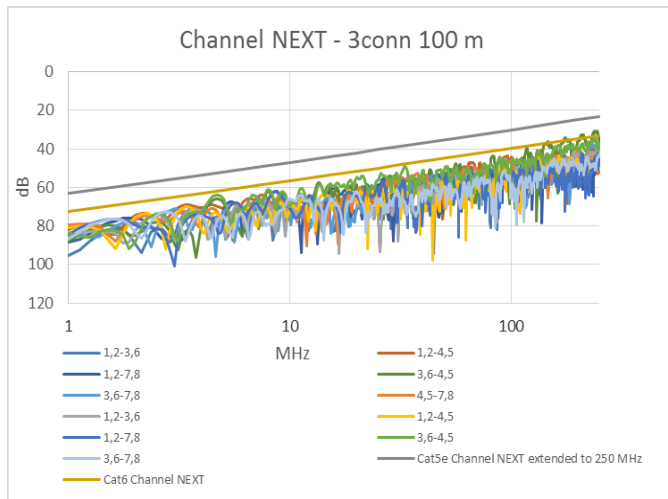

$$NEXT = -20 \cdot \log_{10} \left(10^{\frac{-35.3 - 15 \cdot \log_{10}(f/100)}{20}} + 2 \cdot 10^{\frac{-43 - 20 \cdot \log_{10}(f/100)}{20}} \right) \quad 1 \leq f \leq 100 \text{ MHz}$$

$$-20 \cdot \log_{10} \left(10^{\frac{-35.3 - 15 \cdot \log_{10}(f/100)}{20}} + 2 \cdot 10^{\frac{-43 - 40 \cdot \log_{10}(f/100)}{20}} \right) \quad 100 < f \leq 250 \text{ MHz}$$

$$PSNEXT = -20 \cdot \log_{10} \left(10^{\frac{-32.3 - 15 \cdot \log_{10}(f/100)}{20}} + 2 \cdot 10^{\frac{-40 - 20 \cdot \log_{10}(f/100)}{20}} \right) \quad 1 \leq f \leq 100 \text{ MHz}$$

$$-20 \cdot \log_{10} \left(10^{\frac{-32.3 - 15 \cdot \log_{10}(f/100)}{20}} + 2 \cdot 10^{\frac{-40 - 40 \cdot \log_{10}(f/100)}{20}} \right) \quad 100 < f \leq 250 \text{ MHz}$$

55.7.3 Coupling parameters between link segments

- **55.7.3.1.1 Multiple disturber power sum alien near-end crosstalk (PSANEXT) loss**
 - **55.7.3.1.2 PSANEXT loss to insertion loss ratio requirements**
 - **PSANEXT limits specified in 55.7.3.1.1 [Equation (55–23) and Equation (55–25)]**
- **55.7.3.2 Multiple disturber alien far-end crosstalk (MDAFEXT) loss**
 - **55.7.3.2.1 Multiple disturber power sum alien equal level far-end crosstalk (PSAELFEXT)**
 - **55.7.3.2.2 PSAELFEXT to insertion loss ratio requirements**
 - **PSAELFEXT limits specified in 55.7.3.2. [Equation (55–32) and Equation (55–34)]**

Alien Crosstalk – 10GBASE-T

- **55.7.3.3 Alien crosstalk margin computation**

The alien crosstalk margin computation can be applied in the event that the PSANEXT limits specified in 55.7.3.1.1 [Equation (55–23) and Equation (55–25)] or the PSAELFEXT limits specified in 55.7.3.2. [Equation (55–32) and Equation (55–34)] are not met. The alien crosstalk margin is specified for each of the individual 4-pairs as well as the average “across the 4-pairs”.

Proposal: Alien Crosstalk

- **Use Salz SNR as basis for link segment alien crosstalk specifications (alternative to APMC)**
- **Alien crosstalk cabling limits are not specified for Cat5e or Cat6**
- **Normative alien crosstalk cabling limits are not necessary to consider PHY performance**
- **Salz SNR is used among PHY developers (and others of course) to assess link performance**