

# Survey: Automotive Cabling

## Objective:

The survey is targeted at automotive OEMs and suppliers to be used to assist the IEEE 802.3 Reduced Twisted Pair Study Group (RTPSG) in developing link segment objectives and project criteria.

## **1 Purpose**

The purpose of this survey is to characterize automotive cabling; e.g., cables, connectors, wire harnesses and assemblies *for current and future differential signaling over balanced twisted-pairs*.

The survey information will be used to assist the IEEE 802.3 Reduced Twisted Pair Study Group (RTPSG) in developing link segment objectives and project criteria.

Please take the time to fill in the following questionnaire. Your participation is appreciated.

### **Respondent Information – Automotive cabling survey**

Company and Personal Profile - Please Print

Your Name \_\_\_\_\_

Your Company Name \_\_\_\_\_

City/State/Zip \_\_\_\_\_

E-MAIL \_\_\_\_\_

Your Job Function \_\_\_\_\_

Please return scanned copy of completed survey to  
[cdiminico@ieee.org](mailto:cdiminico@ieee.org)

Chris DiMinico  
MC Communications/  
LEONI Cables & Systems LLC  
Phone: 19784411051

## 1. Survey Questionnaire –

1. Figures 1 is provided as a reference to assist in responding to survey questions. The IEEE 802.3 nomenclature is bracketed to identify relationship to the IEEE 802.3 definitions.

Figure 1 Automotive cabling Topology

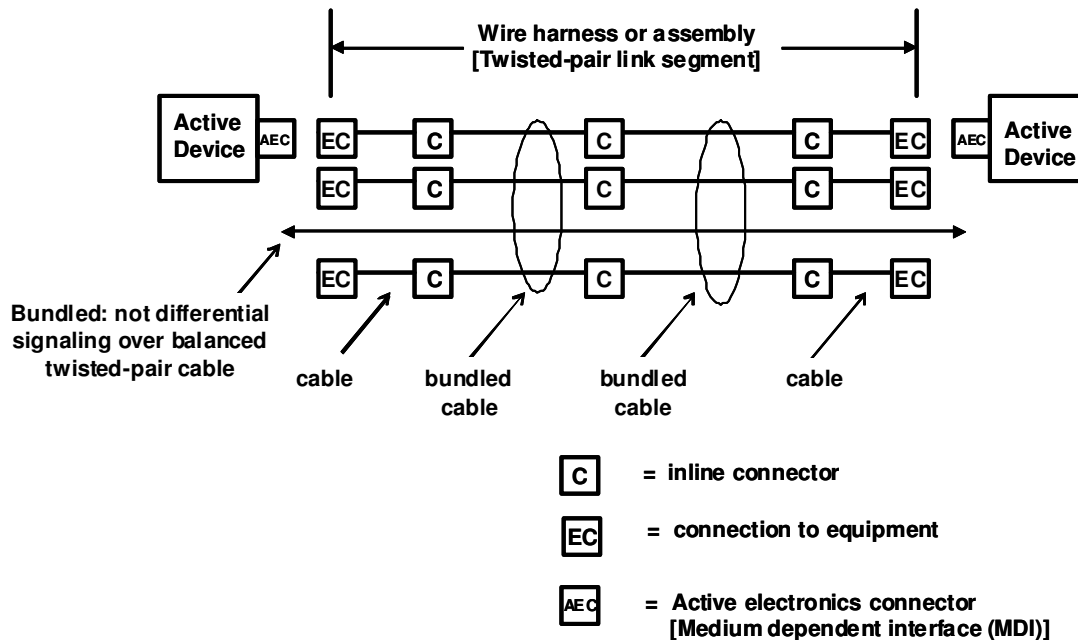

2. Wire harness or assembly topology (see Figure 1).
  - 2.1 Maximum length in meters of wire harness or assembly between active electronic devices – report current applications and lengths [EC] to [EC].  
[meters] length in meters
  - 2.2 Maximum length in meters of wire harness or assembly between active electronic devices – report future applications and lengths [EC] to [EC].  
[meters] length in meters

- 2.3 Number and type of inline connectors [C] between active electronic devices – report current applications.  
[ ] number of connectors  
[ ] [ ] type of connector(s)
- 2.4 Number and type of inline connectors [C] between active electronic devices– report future applications.  
[ ] number of connectors  
[ ] [ ] types of connector(s)
- 2.5 Type of active electronic connectors [AEC] – report current applications.  
[ ] [ ] type of connector(s)
- 2.6 Type of active electronic connectors [AEC] – report future applications.  
[ ] [ ] type of connector(s)
- 2.7 Are there requirements for future applications to be mechanically compatible to existing connector systems?  
[Y/N]
- 2.8 Are there requirements for mechanically compatible connector systems between automobile manufacturers?  
[Y/N]

3. Balanced twisted-pair cable used in wire harness or assembly (see Figure 1 and Figure 2.) report parameters and values.

3.1 Current automotive applications

Gauge	[AWG] [or conductor in mm]
Impedance	[ohm +/- ]
Shield	[Y/N] [shield type]
Copper conductors	[Y/N] solid [Y/N] stranded [#strands]
Direct current resistance	[milliohm/meter]

3.2 Future automotive applications

Gauge	[AWG] [or conductor in mm]
Impedance	[ohm +/- ]
Shield	[Y/N] [shield type]
Copper conductors	[Y/N] solid [Y/N] stranded [#strands]
Direct current resistance	[milliohm/meter]

4. Bundled cable types in wire harnesses or assemblies (Figure 1)

4.1 Report data rates and signaling schemes for differential signaling applications in bundle [data rates and signaling].

4.2 Report other data rates and signaling schemes not using differential signaling in bundle [data rates and signaling].

4.3 Report voltage/power in bundle [ ]

5. External noise sources

5.1 Report steady state noise (including frequency content)

5.2 Report time variable noise (things that come and go)

5.3 Report impulse noise

5.4 Report radio frequency interference - modulated signals (i.e., cell phone type signals)

## 6. Automotive cabling system characteristics

Table 1 is provided as a reference to assist in reporting automotive cabling parameters that are used by Ethernet PHY designers.

Table 1. Cabling parameters

Transmission parameters	Coupling parameters (within Link segments)	Coupling parameters (between Link segments)	Balance parameters
Insertion Loss	Near-End crosstalk (NEXT) loss	Alien Near-End crosstalk loss (ANEXT)	Transverse conversion loss (TCL) – SCD11
Differential characteristic impedance	Multiple disturber near-end crosstalk (MDNEXT) loss	Multiple Disturber Alien Far-End crosstalk loss (MDANEXT)	Longitudinal conversion loss (LCL) – SDC11
Return Loss	Far-End crosstalk (FEXT) loss Specified as equal level FEXT (ELFEXT)	Alien Near-End crosstalk loss (AFEXT)	Transverse conversion transmission loss (TCTL) – SCD12
Propagation Delay	Multiple disturber Far-end crosstalk (MDFEXT) loss Specified as MDELFFEXT (ELFEXT)	Multiple Disturber Alien Far-End crosstalk loss (MDAFEXT) Specified as power sum (PSAELFFEXT)	Longitudinal conversion transmission loss (LCTL) – SDC12
Delay Skew		Specified as power sum (PSAELFFEXT)	

Figures 2 illustrates the coupling parameters NEXT, FEXT within a cable sheath and alien crosstalk between cable sheaths.

Figure 2 Crosstalk within and between cable sheath

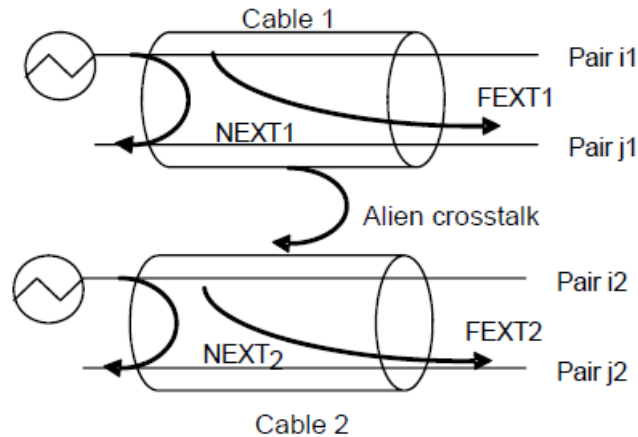

Please check blank cell(s) adjacent to cabling parameters in Table 2 that are used to specify balanced twisted-pair cables and/or connectors used in automotive wire harnesses or assemblies. For each checked box please provide references to either manufacturers specifications or standards specifications (e.g., ISO/IEC, etc) as may apply.

Table 2 Cabling parameters

Check box	Transmission parameters	Check box	Coupling parameters (within Link segments)	Check box	Coupling parameters (between Link segments)	Check box	Balance parameters
	Insertion Loss		Near-End crosstalk (NEXT) loss		Alien Near-End crosstalk loss (ANE <sub>EXT</sub> )		Transverse conversion loss (TCL) – SCD11
	Differential characteristic impedance		Multiple disturber Near-End crosstalk (MDNEXT) loss		Multiple Disturber Alien Far-End crosstalk loss (MDANE <sub>EXT</sub> )		Longitudinal conversion loss (LCL) – SDC11
	Return Loss		Far-End crosstalk (FEXT) loss		Alien Near-End crosstalk loss (AFEXT)		Transverse conversion transmission loss (TCTL) – SCD12
	Propagation Delay		Multiple disturber Far-end crosstalk (MDFEXT)		Multiple Disturber Alien Far-End crosstalk loss (MDAFEXT)		Longitudinal conversion transmission loss (LCTL) – SDC12
	Delay Skew						

Figure 3 and Table 3 provide cross references for cabling parameters naming and s-parameter designations. The red boxes contain the cabling parameters listed in Table 2 and the s-parameter cross references. For cabling measurements between cable sheaths the crosstalk terms NEXT and FEXT are ANEXT and AFEXT respectively.

Figure 3 Four port network

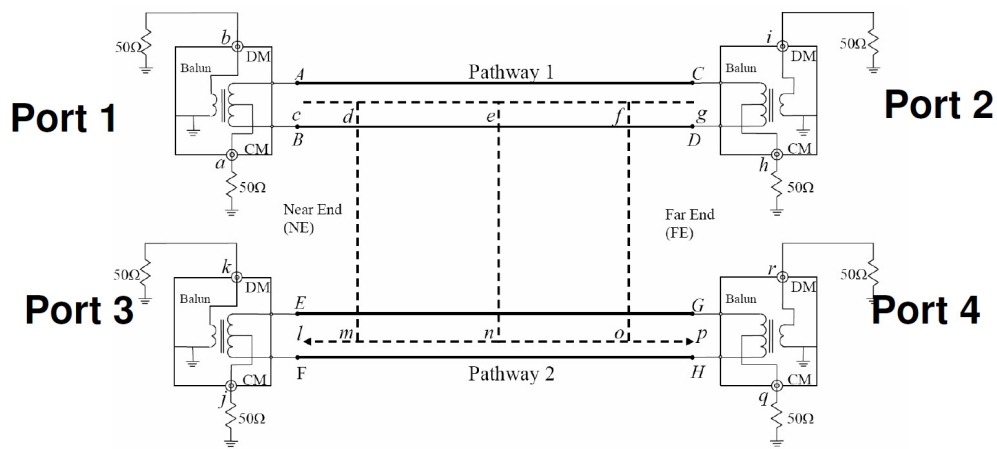
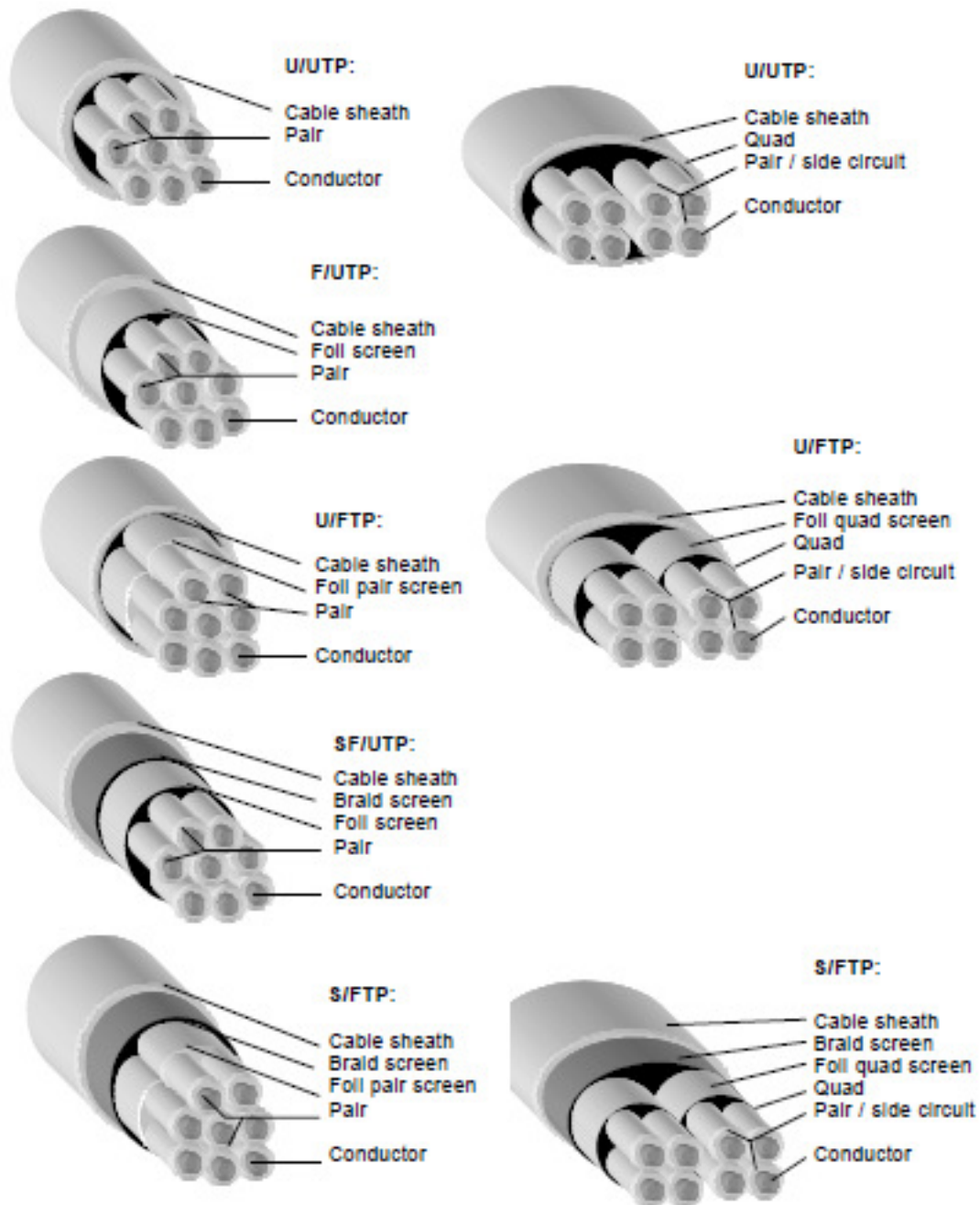

Table 3 Port mapping – signal impairment naming to s-parameters

		Port 1		Port 2		Port 3		Port 4	
Port 1	cc	Scc11	RLcc11	Scc12	ILcc12	Scc13	NEXTcc13	Scc14	FEXTcc14
	cd	Scd11	TCLcd11	Scd12	TCTLcd12	Scd13	NEXTcd13	Scd14	FEXTcd14
	dc	Sdc11	LCLdc11	Sdc12	LCTLdc12	Sdc13	NEXTdc13	Sdc14	FEXTdc14
	dd	Sdd11	RLdd11	Sdd12	ILdd12	Sdd13	NEXTdd13	Sdd14	FEXTdd14
Port 2	cc	Scc21	ILcc21	Scc22	RLcc22	Scc23	FEXTcc23	Scc24	NEXTcc24
	cd	Scd21	TCTLcd21	Scd22	TCLcd22	Scd23	FEXTcd23	Scd24	NEXTcd24
	dc	Sdc21	LCTLdc21	Sdc22	LCLdc22	Sdc23	FEXTdc23	Sdc24	NEXTdc24
	dd	Sdd21	ILdd21	Sdd22	RLdd22	Sdd23	FEXTdd23	Sdd24	NEXTdd24
Port 3	cc	Scc31	NEXTcc31	Scc32	NEXTcc32	Scc33	RLcc33	Scc34	ILcc34
	cd	Scd31	NEXTcd31	Scd32	NEXTcd32	Scd33	TCLcd33	Scd34	TCTLcd34
	dc	Sdc31	NEXTdc31	Sdc32	NEXTdc32	Sdc33	LCLdc33	Sdc34	LCTLdc34
	dd	Sdd31	NEXTdd31	Sdd32	NEXTdd32	Sdd33	RLdd33	Sdd34	ILdd34
Port 4	cc	Scc41	FEXTcc41	Scc42	FEXTcc42	Scc43	ILcc43	Scc44	RLcc44
	cd	Scd41	FEXTcd41	Scd42	FEXTcd42	Scd43	TCTLcd43	Scd44	TCLcd44
	dc	Sdc41	FEXTdc41	Sdc42	FEXTdc42	Sdc43	LCTLdc43	Sdc44	LCLdc44
	dd	Sdd41	FEXTdd41	Sdd42	FEXTdd42	Sdd43	ILdd43	Sdd44	RLdd44



Figure 4 Cable types\*



\*ISO/IEC 11801 Second edition 2002-09 Figure E.2 – Cable types