1000BASE-Tx

Link Segment Baseline Proposal

Chris DiMinico
MC Communications/Panduit
cdiminico@ieee.org

Supporters

- Your name here

Purpose

- **To propose a baseline for the 1000BASE-Tx link segment(s) based on**
 - **802.3bp project objectives**
 - **Inputs from EMC and Channel definitions ad hoc**
 - **Automotive cabling survey**
 - **RTPGE study group and 802.3bp Task Force presentations**

802.3bp Objectives

- **Preserve the IEEE 802.3/Ethernet frame format at the MAC client service interface.**
- **Preserve minimum and maximum frame size of the current IEEE 802.3 standard.**
- **Support full duplex operation only.**
- **Support a speed of 1 Gb/s at the MAC/PLS service interface.**
- **Maintain a bit error ratio (BER) of less than or equal to 10^{-10} at the MAC/PLS service interface**
- **Support 1 Gb/s operation in automotive & industrial environments (e.g. EMC, temperature).**
- **Define optional Energy-Efficient Ethernet**

• *APPROVED 802.3 WG (November 15, 2012)*

802.3bp Objectives

- **Define the performance characteristics of an automotive link segment and a PHY to support point-to-point operation over this link segment with less than three twisted pairs supporting up to four inline connectors using balanced copper cabling for at least 15m for the automotive link segment.**
- **Define the performance characteristics of optional link segment(s) for the above PHY for industrial controls and/or automation, transportation (aircraft, railway, bus and heavy trucks) applications with a goal of at least 40m reach**
- **Define optional startup procedure which enables the time from power_on=FALSE to valid data to be less than 100ms**

•APPROVED 802.3 WG (November 15, 2012)

Link segment definition process

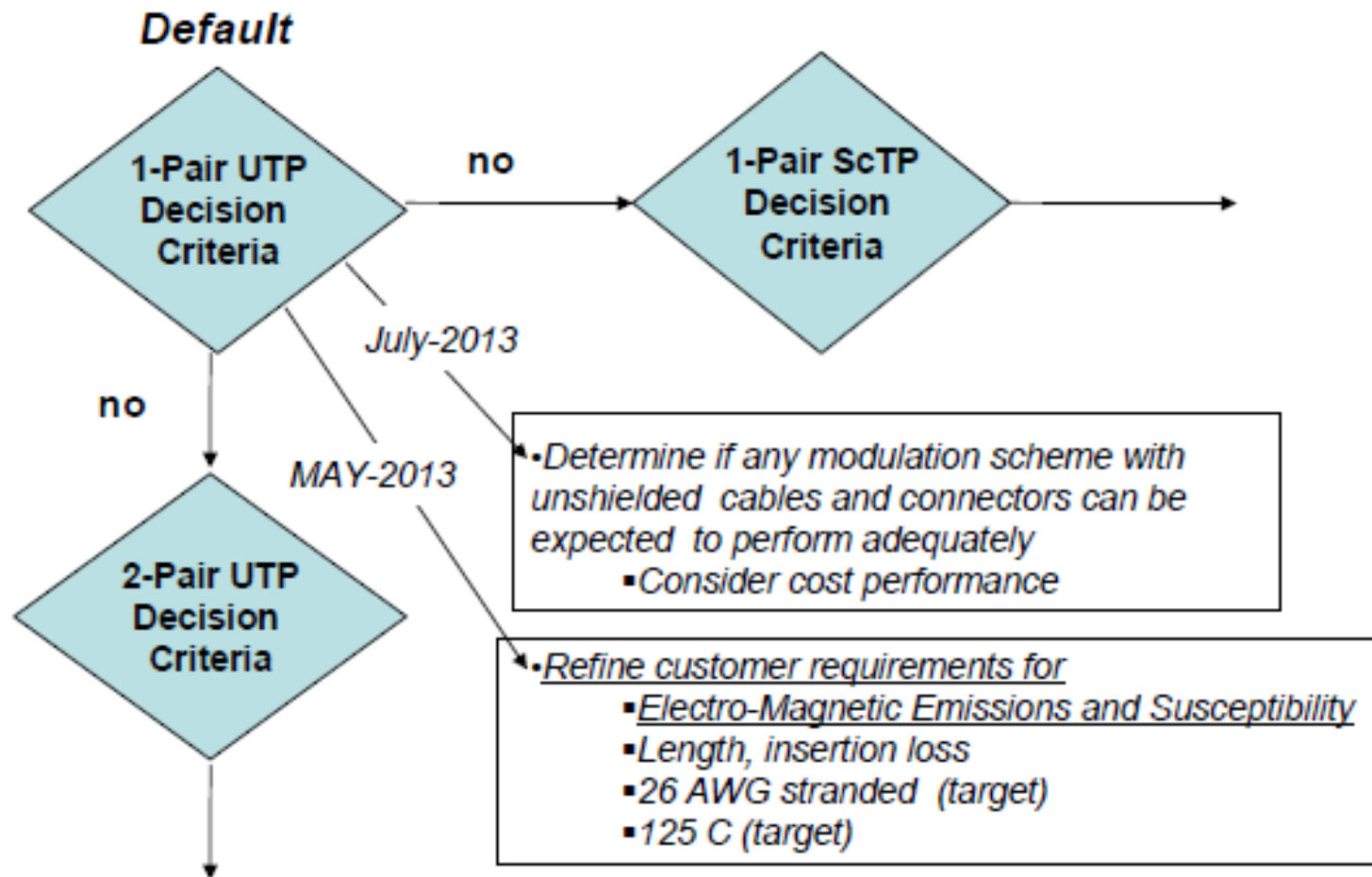

Source: http://www.ieee802.org/3/bp/public/mar13/diminico_3bp_02_0313.pdf

Affirmation of 1-pair

Motion

Move that:

The IEEE P802.3bp Task Force affirms a 1-pair PHY Solution at 15m.

- M: Matheus, K.
- S: Diab, W.

• Y: 32 N: 0 A: 7

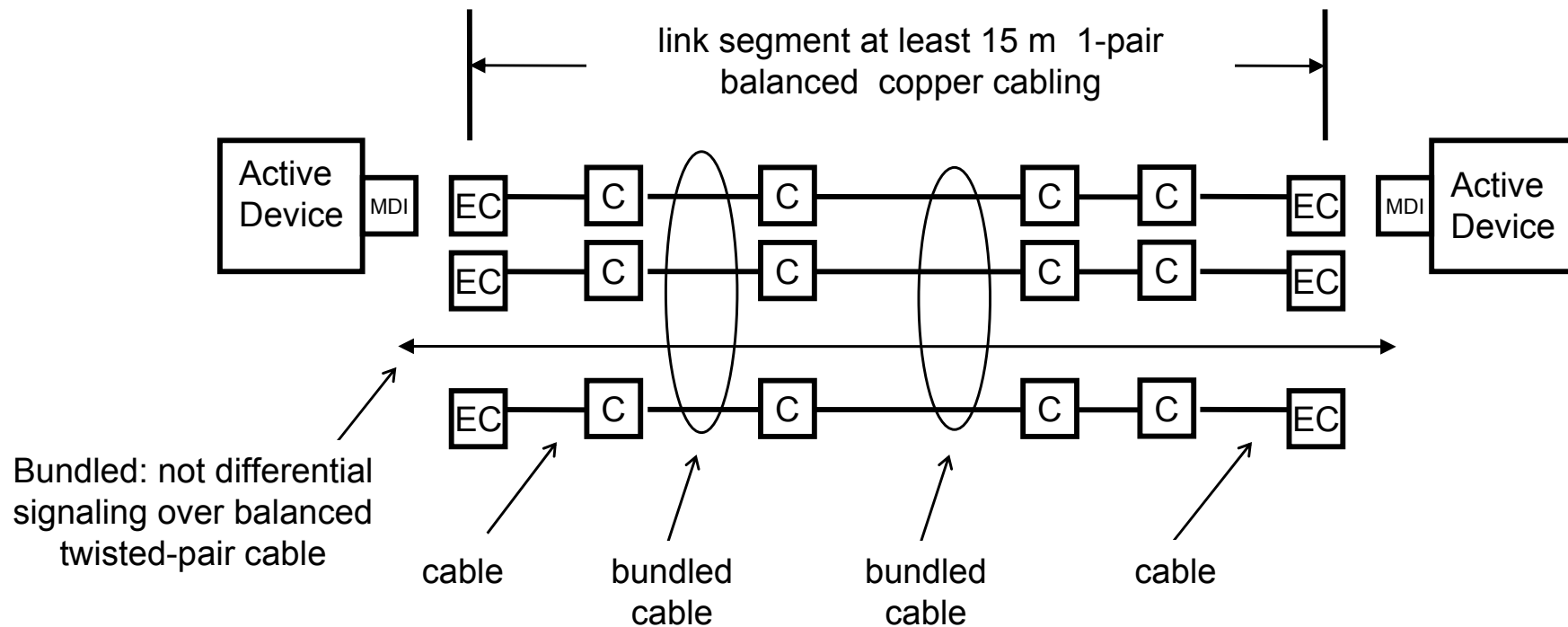

Source: http://www.ieee802.org/3/bp/public/may13/tezebay_3bp_02_0513.pdf

1000BASE-Tx Link Segment



The IEEE 802.3 nomenclature is bracketed to identify relationship to the IEEE 802.3 definitions.

Length objective [EC] to [EC] at least 15 m
Number of inline connectors [C] = 4

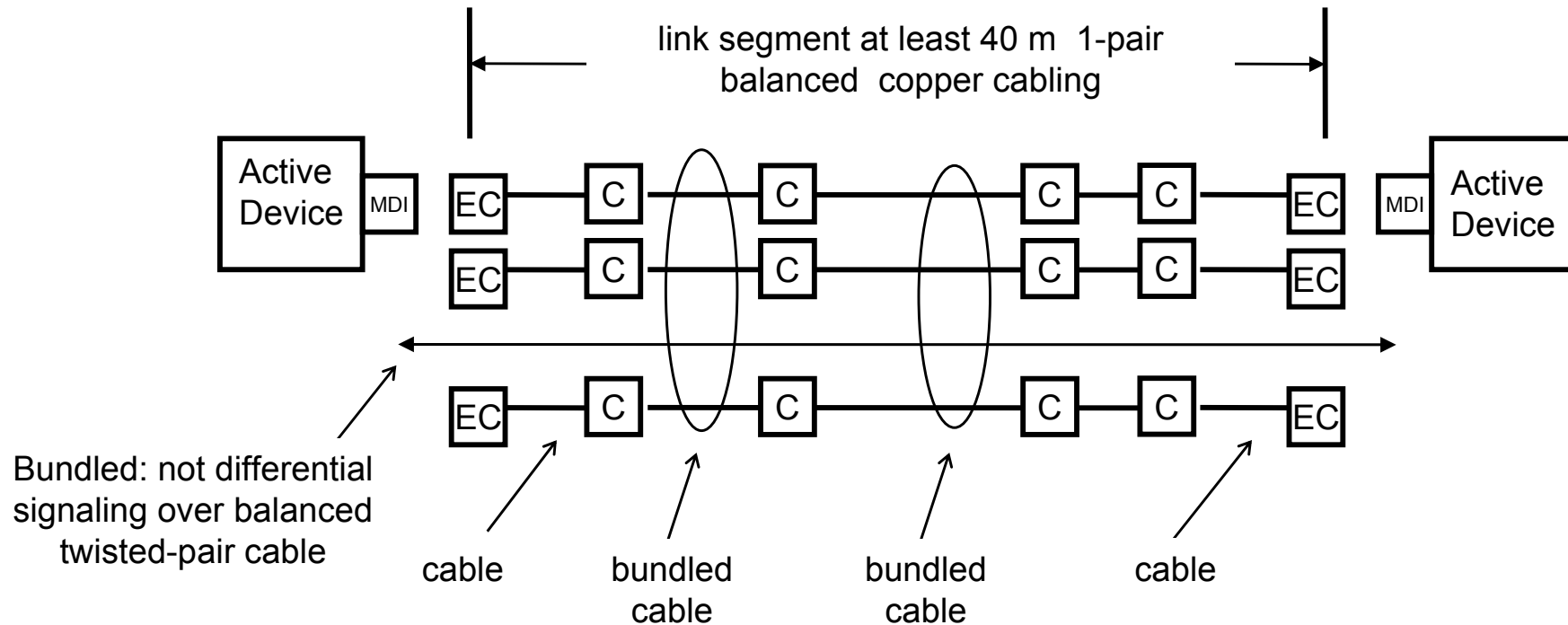

-  = inline connector
-  = connection to equipment
-  = Active electronics connector [Medium dependent interface (MDI)]

1000BASE-Tx Link Segment (optional)



The IEEE 802.3 nomenclature is bracketed to identify relationship to the IEEE 802.3 definitions.

Length objective [EC] to [EC] at least 40 m
Number of inline connectors [C] = 4

-  = inline connector
-  = connection to equipment
-  = Active electronics connector [Medium dependent interface (MDI)]

Automotive operating environment

Introduction:

Definitions:

IL – Insertion Loss (SDD21)

RL – Return Loss (SDD22)

Frequency measurements were taken at the following temperatures :

- 40 C (required per USCAR-2, GMW3191 – Classes 1, 2 & 3)

+23 C (common temperature for most tests)

+85 C (required per USCAR-2, GMW3191 – Class 1)

+105 C (required per GMW3191; USCAR-2 requires 100 C – Class 2)

+125 C (required per USCAR-2, GMW3191 – Class 3)

Per GMW3191 and USCAR-2:

Class 1 – passenger compartment

Class 2 – under the hood or on chassis

Class 3 – on engine

Automotive operating environment

Lifetime Requirements and Testing of ECUs

Active Operation: Typical Temperature-Load Distribution (ambient)

T _{1,ECU} = ECU inner air temperature	Typ. load (Passenger Car)	
	Vehicle body, bulkhead, extension close to the engine	
-40°C...10° C	6.0 %	480 h
10°C...45° C	20.0 %	1600 h
45°C...60° C	33.0 %	2640 h
60°C...70° C	18.0 %	1440 h
70°C...80° C	9.0 %	720 h
...85° C	3.0 %	240 h
...90° C	2.0 %	160 h
...95° C	1.7 %	136 h
...100° C	1.5 %	120 h
...105° C	1.4 %	112 h
...110° C	1.3 %	104 h
...115° C	1.2 %	96 h
...120° C	1.0 %	80 h
...125° C	0.9 %	72 h
Total	100%	8000 h



Link segment transmission parameters

Link segment transmission and coupling parameters

- Insertion loss
- Return loss
- Alien Crosstalk
 - ANEXT, AFEXT, power sum
- Balance – MTZ (proposed limits) – Next week
 - Cable measurements (UNH-IOL)
 - Link measurements (including MDI)
 - UNH-IOL soliciting inputs (MDI)
 - Coordinate with EMC group test plan and test fixtures

Channel Performance Formulation Proposal -Todd Herman CommScope

equations for insertion loss of 1-pair ethernet channel

For 20 degrees C and AWG 23

$$IL := \left(1.2 \cdot \frac{L}{100} \right) \cdot \left(1.82 \cdot \sqrt{f} + .0091 \cdot f + \frac{.25}{\sqrt{f}} \right) + B \cdot .02 \cdot \sqrt{f}$$

where

B := number of connectors

f := frequency_MHz

L..length_m

Inline connector IL

20% increase for stranded

Category 6A reference (23 AWG)

For any temperature above 20 degrees C and for any conductor size

$$IL := [1 + .004 \cdot (T - 20)] \cdot \left(1.2 \cdot \frac{L}{100} \right) \cdot \left[\frac{1.82}{\frac{(23-n)}{92}^{39}} \cdot \sqrt{f} + .0091 \cdot f + \frac{.25}{\sqrt{f}} \right] + B \cdot .02 \cdot \sqrt{f}$$

where

T := Temperature in degrees_C

n := conductor_size_in_AWG

~12% increase for each gauge reduction

insertion loss adjusted using a factor of 0.4 % increase per °C from 20 °C to 125 °C

Cable insertion loss dB @ 500 MHz

AWG	Diameter (in)	Diameter (mm)	dB/m at 500 MHz solid	dB/m at 500 MHz stranded	dB/15m stranded	dB/40m stranded
22	0.025346	0.643795	0.40	0.48	7.25	19.35
23	0.022571	0.573314	0.45	0.54	8.15	21.72
24	0.020100	0.510549	0.51	0.61	9.15	24.39
25	0.017900	0.454655	0.57	0.68	10.27	27.39
26	0.015940	0.404881	0.64	0.77	11.54	30.76
27	0.014195	0.360555	0.72	0.86	12.95	34.54
28	0.012641	0.321083	0.81	0.97	14.55	38.79
29	0.011257	0.285931	0.91	1.09	16.33	43.56
30	0.010025	0.254628	1.02	1.22	18.34	48.91
31	0.008927	0.226752	1.14	1.37	20.60	54.93
32	0.007950	0.201928	1.28	1.54	23.13	61.68

- IL(f)
- Reference IL (dB/100m) = $1.82 \cdot \text{SQRT}(f) + 0.0091 \cdot f + 0.25 / \text{SQRT}(f)$
- Reference IL (dB/m) = $0.01 \cdot (1.82 \cdot \text{SQRT}(f) + 0.0091 \cdot f + 0.25 / \text{SQRT}(f))$
- 20% increase for stranded (dB/m) = $1.2 \cdot (0.01 \cdot (1.82 \cdot \text{SQRT}(f) + 0.0091 \cdot f + 0.25 / \text{SQRT}(f)))$
- 12% increase per gauge (dB/m) = $1.12 \cdot (0.01 \cdot (1.82 \cdot \text{SQRT}(f) + 0.0091 \cdot f + 0.25 / \text{SQRT}(f)))$

Source: diminico_02_0313_rtpge.pdf

Link segment baseline proposal

Cable IL

Temperature correction

- Insertion loss adjusted using a factor of 0.4 % increase per °C from 20 °C to 125 °C
- Temperature coefficient = $1 + 0.004 * (125 - 20) = 1.42$

Solid to stranded conductor

- 20% increase for stranded

Sqrt(f) coefficient correction for 26 AWG vs 24 AWG

- Sqrt(f) coefficient = $1.82 / (92^{((23-26)/39)}) = 2.58$

Length correction from 100 m to 15 m = $(15/100)$

Connector IL

- Connector IL = $4 * 0.02 * \text{SQRT}(f)$

$$= \left[(1.42 * (1.2 * 15/100)) * (2.58 * \text{SQRT}(f) + 0.0091 * f + 0.25 / \text{SQRT}(f)) \right] \left[+4 * 0.02 * \text{SQRT}(f) \right]$$

Link segment baseline proposal

Link segment IL – 4 connectors - 26 AWG - to 125 °C

$$= (1.42*(1.2*15/100)*(2.58*\text{SQRT}(f)+0.0091*f+0.25/\text{SQRT}(f))) + 4*0.02*\text{SQRT}(f)$$

ILD term (TBD) based on RL proposal

Link segment IL proposal = $0.6587*\text{SQRT}(f)+0.0023*f+0.0639/\text{SQRT}(f)+.08*\text{SQRT}(f) + \text{ILD}(f)$

