

# Survey: Automotive Cabling

## Objective:

The survey is targeted at automotive OEMs and suppliers to be used to assist the IEEE 802.3 Reduced Twisted Pair Study Group (RTPSG) in developing link segment objectives and project criteria.

## IMPORTANT NOTICE

This survey has been prepared to assist the IEEE 802.3 Working Group / Reduced Twisted Pair Study Group (RTPSG) in its standards development work. Your response to this survey will be a contribution to the IEEE, and you grant IEEE a non-exclusive, irrevocable, worldwide royalty-free, *right to use* the contribution. You are also cautioned that your contribution may be disclosed in public or semi-public forums and should not include competitively sensitive information.

For more information, see:

IEEE Standards Association (IEEE-SA) Copyright Policy available at  
<<http://standards.ieee.org/IPR/copyrightpolicy.html>>

*Promoting Competition and Innovation: What You Need to Know about the IEEE Standards Association's Antitrust and Competition Policy*, available at  
<<http://standards.ieee.org/develop/policies/antitrust.pdf>>

IEEE patent policy in Section 6.3 of the IEEE-SA Standards Board Operations Manual  
<<http://standards.ieee.org/guides/opman/sect6.html#6.3>>

*Understanding Patent Issues During IEEE Standards Development*  
<<http://standards.ieee.org/board/pat/guide.html>>.

## **1 Purpose**

The purpose of the survey is to characterize automotive cabling; e.g., cables, connectors, wire harnesses and assemblies *for current and future differential signaling over balanced twisted-pairs.*

The survey information will be used to assist the IEEE 802.3 Reduced Twisted Pair Study Group (RTPSG) in developing link segment objectives and project criteria.

Please take the time to fill in the following questionnaire. Your participation is appreciated.

### **Respondent Information – Automotive cabling survey**

Company and Personal Profile - Please Print

Your Name \_\_\_\_\_

Your Company Name \_\_\_\_\_

City/State/Zip \_\_\_\_\_

E-MAIL \_\_\_\_\_

Your Job Function \_\_\_\_\_

## 1. Survey Questionnaire –

1. Figures 1 is provided as a reference to assist in responding to survey questions. The IEEE 802.3 nomenclature is bracketed to identify relationship to the IEEE 802.3 definitions.

Figure 1 Automotive cabling Topology

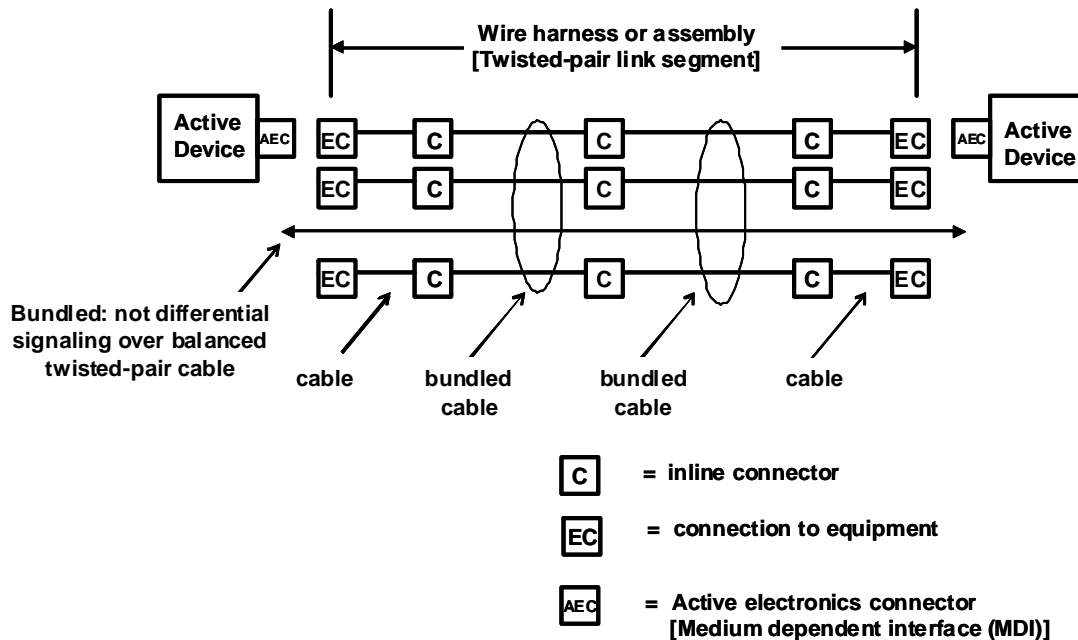

2. Wire harness or assembly topology (see Figure 1).

- 2.1 Maximum length in meters of wire harness or assembly between active electronic devices – report current applications and lengths [EC] to [EC].  
[ meters ] length in meters
- 2.2 Maximum length in meters of wire harness or assembly between active electronic devices – report future applications and lengths [EC] to [EC].  
[ meters ] length in meters

- 2.3 Number and type of inline connectors [C] between active electronic devices – report current applications.  
 number of connectors  
 type of connector(s)
- 2.4 Number and type of inline connectors [C] between active electronic devices– report future applications  
 number of connectors  
 types of connector(s)
- 2.5 Type of active electronic connectors [AEC] – report current applications.  
 type of connector(s)
- 2.6 Type of active electronic connectors [AEC] – report future applications.  
 type of connector(s)
- 2.7 Number and type of inline connectors [C] between active electronic devices– report future applications  
 number of connectors  
 type of connectors
- 2.8 Are there requirements for future applications to be mechanically compatible to existing connector systems?  
[Y/N]
- 2.9 Are there requirements for mechanically compatible connector systems between automobile manufacturers?  
[Y/N]

3. Balanced twisted-pair cable used in wire harness or assembly (see Figure 1 and Figure 2.) report parameters and values.

3.1 Current automotive applications

Gauge [AWG] [or conductor in mm]  
Impedance [ohm +/- ]  
Shield [Y/N] [shield type]  
Copper conductors [Y/N] solid [Y/N] stranded [#strands]  
Direct current resistance [milliohm/meter]

3.2 Future automotive applications

Gauge [AWG] [or conductor in mm]  
Impedance [ohm +/- ]  
Shield [Y/N] [shield type]  
Copper conductors [Y/N] solid [Y/N] stranded [#strands]  
Direct current resistance [milliohm/meter]

4. Bundled cable types in wire harness or assembly (Figure 1)

4.1 Report data rates of differential signaling applications in bundle [data rate]

4.2 Report other data rates not using differential signaling in bundle [ ]

4.3 Report voltage/power in bundle [ ]

5. External noise sources

5.1 Report steady state noise (including frequency content)

5.2 Report time variable noise (things that come and go)

5.3 Report impulse noise

5.4 Report radio frequency interference - modulated signals (i.e., cell phone type signals)

## 6. Automotive cabling system characteristics

Table 1 is provided as a reference to assist in reporting automotive cabling parameters that are used by Ethernet PHY designers.

Table 1. Cabling parameters

| Transmission parameters               | Coupling parameters (within Link segments)   | Coupling parameters (between Link segments)   | Balance parameters                                       |
|---------------------------------------|--|---|--|
| Insertion Loss                        | Near-End crosstalk (NEXT) loss   | Alien Near-End crosstalk loss (ANEXT)   | Transverse conversion loss (TCL) – SCD11                 |
| Differential characteristic impedance | Multiple disturber near-end crosstalk (MDNEXT) loss                                | Multiple Disturber Alien Far-End crosstalk loss (MDANEXT)                                     | Longitudinal conversion loss (LCL) – SDC11               |
| Return Loss                           | Far-End crosstalk (FEXT) loss Specified as equal level FEXT (ELFEXT)               | Alien Near-End crosstalk loss (AFEXT)   | Transverse conversion transmission loss (TCTL) – SCD12   |
| Propagation Delay                     | Multiple disturber Far-end crosstalk (MDFEXT) loss Specified as MDELFFEXT (ELFEXT) | Multiple Disturber Alien Far-End crosstalk loss (MDAFEXT) Specified as power sum (PSAELFFEXT) | Longitudinal conversion transmission loss (LCTL) – SDC12 |
| Delay Skew                            |  | Specified as power sum (PSAELFFEXT)   |  |

Figures 2 illustrates the coupling parameters NEXT, FEXT within a cable sheath and alien crosstalk between cable sheaths.

Figure 2 Crosstalk within and between cable sheath

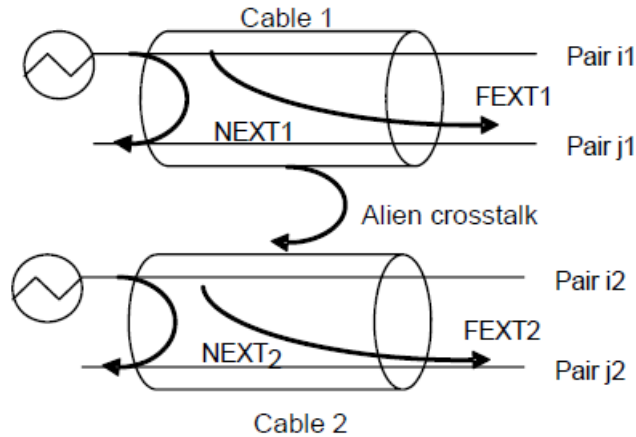

Please check blank cell adjacent to cabling parameters in Table 2 that are used to specify balanced twisted-pair cables and/or connectors used with twisted-pair cables in automotive wire harnesses or assemblies.

Table 2 Cabling parameters

| Check box | Transmission parameters               | Check box | Coupling parameters (within Link segments)          | Check box | Coupling parameters (between Link segments)               | Check box | Balance parameters                                       |
|-----------|---------------------------------------|-----------|---|-----------|---|-----------|--|
|           | Insertion Loss                        |           | Near-End crosstalk (NEXT) loss                      |           | Alien Near-End crosstalk loss (ANEXT)                     |           | Transverse conversion loss (TCL) – SCD11                 |
|           | Differential characteristic impedance |           | Multiple disturber Near-End crosstalk (MDNEXT) loss |           | Multiple Disturber Alien Far-End crosstalk loss (MDANEXT) |           | Longitudinal conversion loss (LCL) – SDC11               |
|           | Return Loss                           |           | Far-End crosstalk (FEXT) loss                       |           | Alien Near-End crosstalk loss (AFEXT)                     |           | Transverse conversion transmission loss (TCTL) – SCD12   |
|           | Propagation Delay                     |           | Multiple disturber Far-end crosstalk (MDFEXT)       |           | Multiple Disturber Alien Far-End crosstalk loss (MDAFEXT) |           | Longitudinal conversion transmission loss (LCTL) – SDC12 |
|           | Delay Skew                            |           |   |           |   |           |  |

Figure 3 and Table 3 provide references for signaling impairments naming and s-parameter designations derived from four port network.

Figure 3 Four port network

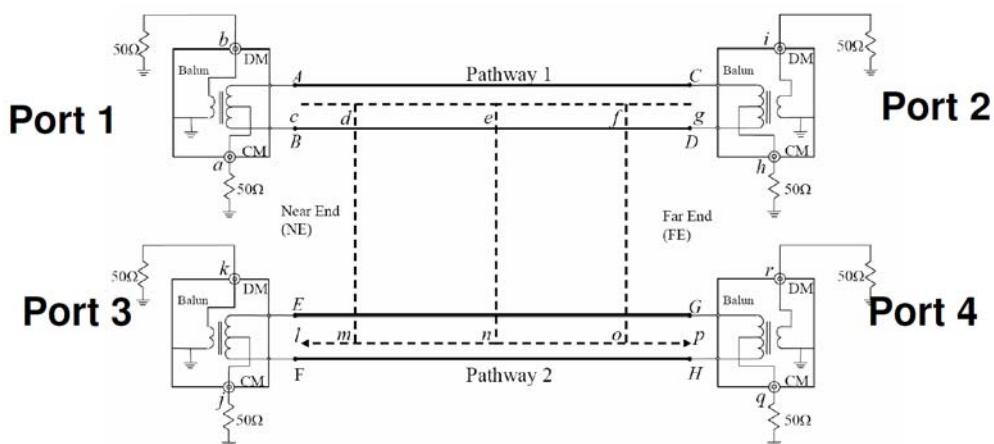

Table 3 Port mapping – signal impairment naming to s-parameters

|        |    | Port 1              |                       | Port 2              |                       | Port 3              |                       | Port 4              |                       |
|--------|----|---------------------|-----------------------|---------------------|-----------------------|---------------------|-----------------------|---------------------|-----------------------|
| Port 1 | cc | Sc <sub>c</sub> 11  | RL <sub>cc</sub> 11   | Sc <sub>c</sub> 12  | IL <sub>cc</sub> 12   | Sc <sub>c</sub> 13  | NEXT <sub>cc</sub> 13 | Sc <sub>c</sub> 14  | FEXT <sub>cc</sub> 14 |
|        | cd | Sc <sub>d</sub> 11  | TCL <sub>d</sub> 11   | Sc <sub>d</sub> 12  | TCTL <sub>d</sub> 12  | Sc <sub>d</sub> 13  | NEXT <sub>cd</sub> 13 | Sc <sub>d</sub> 14  | FEXT <sub>cd</sub> 14 |
|        | dc | Sc <sub>d</sub> c11 | LCL <sub>dc</sub> 11  | Sc <sub>d</sub> c12 | LCTL <sub>dc</sub> 12 | Sc <sub>d</sub> c13 | NEXT <sub>dc</sub> 13 | Sc <sub>d</sub> c14 | FEXT <sub>dc</sub> 14 |
|        | dd | S <sub>dd</sub> 11  | RL <sub>dd</sub> 11   | S <sub>dd</sub> 12  | IL <sub>dd</sub> 12   | S <sub>dd</sub> 13  | NEXT <sub>dd</sub> 13 | S <sub>dd</sub> 14  | FEXT <sub>dd</sub> 14 |
| Port 2 | cc | Sc <sub>c</sub> 21  | IL <sub>cc</sub> 21   | Sc <sub>c</sub> 22  | RL <sub>cc</sub> 22   | Sc <sub>c</sub> 23  | FEXT <sub>cc</sub> 23 | Sc <sub>c</sub> 24  | NEXT <sub>cc</sub> 24 |
|        | cd | Sc <sub>d</sub> 21  | TCTL <sub>d</sub> 21  | Sc <sub>d</sub> 22  | TCL <sub>d</sub> 22   | Sc <sub>d</sub> 23  | FEXT <sub>cd</sub> 23 | Sc <sub>d</sub> 24  | NEXT <sub>cd</sub> 24 |
|        | dc | Sc <sub>d</sub> c21 | LCTL <sub>dc</sub> 21 | Sc <sub>d</sub> c22 | LCL <sub>dc</sub> 22  | Sc <sub>d</sub> c23 | FEXT <sub>dc</sub> 23 | Sc <sub>d</sub> c24 | NEXT <sub>dc</sub> 24 |
|        | dd | S <sub>dd</sub> 21  | IL <sub>dd</sub> 21   | S <sub>dd</sub> 22  | RL <sub>dd</sub> 22   | S <sub>dd</sub> 23  | FEXT <sub>dd</sub> 23 | S <sub>dd</sub> 24  | NEXT <sub>dd</sub> 24 |
| Port 3 | cc | Sc <sub>c</sub> 31  | NEXT <sub>cc</sub> 31 | Sc <sub>c</sub> 32  | NEXT <sub>cc</sub> 32 | Sc <sub>c</sub> 33  | RL <sub>cc</sub> 33   | Sc <sub>c</sub> 34  | IL <sub>cc</sub> 34   |
|        | cd | Sc <sub>d</sub> 31  | NEXT <sub>cd</sub> 31 | Sc <sub>d</sub> 32  | NEXT <sub>cd</sub> 32 | Sc <sub>d</sub> 33  | TCL <sub>d</sub> 33   | Sc <sub>d</sub> 34  | TCTL <sub>d</sub> 34  |
|        | dc | Sc <sub>d</sub> c31 | NEXT <sub>dc</sub> 31 | Sc <sub>d</sub> c32 | NEXT <sub>dc</sub> 32 | Sc <sub>d</sub> c33 | LCL <sub>dc</sub> 33  | Sc <sub>d</sub> c34 | LCTL <sub>dc</sub> 34 |
|        | dd | S <sub>dd</sub> 31  | NEXT <sub>dd</sub> 31 | S <sub>dd</sub> 32  | NEXT <sub>dd</sub> 32 | S <sub>dd</sub> 33  | RL <sub>dd</sub> 33   | S <sub>dd</sub> 34  | IL <sub>dd</sub> 34   |
| Port 4 | cc | Sc <sub>c</sub> 41  | FEXT <sub>cc</sub> 41 | Sc <sub>c</sub> 42  | FEXT <sub>cc</sub> 42 | Sc <sub>c</sub> 43  | IL <sub>cc</sub> 43   | Sc <sub>c</sub> 44  | RL <sub>cc</sub> 44   |
|        | cd | Sc <sub>d</sub> 41  | FEXT <sub>cd</sub> 41 | Sc <sub>d</sub> 42  | FEXT <sub>cd</sub> 42 | Sc <sub>d</sub> 43  | TCTL <sub>d</sub> 43  | Sc <sub>d</sub> 44  | TCL <sub>d</sub> 44   |
|        | dc | Sc <sub>d</sub> c41 | FEXT <sub>dc</sub> 41 | Sc <sub>d</sub> c42 | FEXT <sub>dc</sub> 42 | Sc <sub>d</sub> c43 | LCTL <sub>dc</sub> 43 | Sc <sub>d</sub> c44 | LCL <sub>dc</sub> 44  |
|        | dd | S <sub>dd</sub> 41  | FEXT <sub>dd</sub> 41 | S <sub>dd</sub> 42  | FEXT <sub>dd</sub> 42 | S <sub>dd</sub> 43  | IL <sub>dd</sub> 43   | S <sub>dd</sub> 44  | RL <sub>dd</sub> 44   |



Figure 4 Cable types

