

97.4 Physical Medium Attachment (PMA) sublayer

97.4.1 PMA functional specifications

The PMA couples messages from a PMA service interface specified in 97.2.2 to the 1000BASE-T1 baseband medium, specified in 97.7.

The interface between PMA and the baseband medium is the Medium Dependent Interface (MDI), which is specified in 97.8.

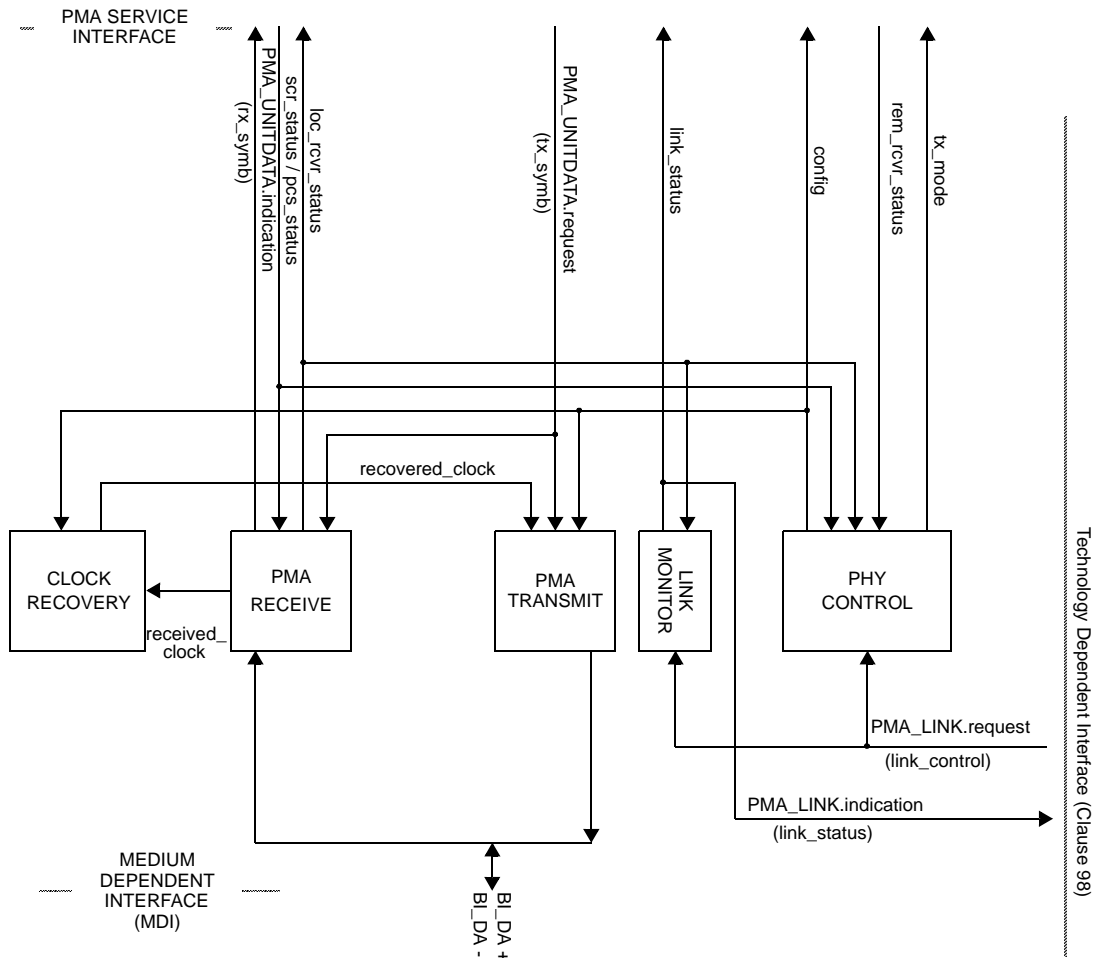

Figure 97-12—PMA reference diagram

NOTE—The recovered_clock arc is shown to indicate delivery of the recovered clock signal back to PMA TRANSMIT for loop timing.

97.4.2 PMA functions

The PMA sublayer comprises one PMA Reset function and five simultaneous and asynchronous operating functions. The PMA operating functions are PHY Control, PMA Transmit, PMA Receive, Link Monitor, and Clock Recovery. All operating functions are started immediately after the successful completion of the PMA Reset function.

The PMA reference diagram, Figure 97–12, shows how the operating functions relate to the messages of the PMA Service interface and the signals of the MDI. Connections from the management interface, comprising the signals MDC and MDIO, to other layers are pervasive and are not shown in Figure 97–12.

97.4.2.1 PMA Reset function

The PMA Reset function shall be executed whenever one of the two following conditions occur:

- a) Power on (see 97.3.5.2.2)
- b) The receipt of a request for reset from the management entity

All state diagrams take the open-ended pma_reset branch upon execution of PMA Reset. The reference diagrams do not explicitly show the PMA Reset function.

97.4.2.2 PMA Transmit function

The PMA Transmit function comprises a transmitter to generate a 3 level modulated signals on the single twisted pair. PMA Transmit shall continuously transmit onto the MDI pulses modulated by the symbols given by tx_symb after processing with optional transmit filtering, digital to analog conversion (DAC) and subsequent analog filtering. The signals generated by PMA Transmit shall comply with the electrical specifications given in 97.5.

When the PMA_CONFIG.indication parameter config is MASTER, the PMA Transmit function shall source TX_TCLK from a local clock source while meeting the transmit jitter requirements of 97.5.3.3. The MASTER/SLAVE relationship shall include loop timing. If the PMA_CONFIG.indication parameter config is SLAVE, the PMA Transmit function shall source TX_TCLK from the recovered clock of 97.4.2.7 while meeting the jitter requirements of 97.5.3.3.

The PMA Transmit fault function is optional. The faults detected by this function are implementation specific. If the MDIO interface is implemented, then this function shall be mapped to the transmit fault bit as specified in 45.2.1.7.4.

97.4.2.3 PMA transmit disable function

97.4.2.3.1 Global PMA transmit disable function

When the Global_PMA_transmit_disable variable is set to TRUE, this function shall turn off the transmitter so that the transmitter Average Launch Power of the Transmitter is less than –53 dBm.

97.4.2.3.2 PMA MDIO function mapping

The MDIO capability described in Clause 45 defines several variables that provide control and status information for and about the PMA. Mapping of MDIO control variables to PMA control variables is shown in Table 97–3. Mapping of MDIO status variables to PMA status variables is shown in Table 97–4.

Table 97-3—MDIO/PMA control variable mapping

MDIO control variable	PMA register name	Register/bit number	PMA control variable
Reset	Control register 1	1.0.15	PMA_reset
Global transmit disable	Transmit disable register	1.9.0	Global_PMA_transmit_disable

Table 97-4—MDIO/PMA status variable mapping

MDIO status variable	PMA register name	Register/bit number	PMA status variable
Fault	Status register 1	1.1.7	PMA_fault
Transmit fault	Status register 2	1.8.11	PMA_transmit_fault
Receive fault	Status register 2	1.8.10	PMA_receive_fault

97.4.2.4 PMA Receive function

The PMA Receive function comprises a receiver for PAM3 signals on the twisted pair. PMA Receive contains the circuits necessary to both detect symbol sequences from the signals received at the MDI over receive pair and to present these sequences to the PCS Receive function. The PMA translates the signals received on the twisted pair into the PMA_UNITDATA.indication parameter rx_symb. The quality of these symbols shall allow RFER of less than 3.6×10^{-7} after RS decoding, over a channel meeting the requirements of 97.7.

To achieve the indicated performance, it is highly recommended that PMA Receive include the functions of signal equalization and echo cancellation. The sequence of symbols assigned to tx_symb is needed to perform echo cancellation.

The PMA Receive function uses the scr_status parameter and the state of the equalization, cancellation, and estimation functions to determine the quality of the receiver performance, and generates the loc_rcvr_status variable accordingly. The precise algorithm for generation of loc_rcvr_status is implementation dependent.

The receiver uses the sequence of symbols during the training sequence to detect and correct for pair polarity swaps.

The PMA Receive fault function is optional. The PMA Receive fault function is the logical OR of the link_status = FAIL and any implementation specific fault. If the MDIO interface is implemented, then this function shall contribute to the receive fault bit specified in 45.2.1.7.5.

97.4.2.5 PHY Control function

PHY Control generates the control actions that are needed to bring the PHY into a mode of operation during which frames can be exchanged with the link partner. PHY Control shall comply with the state diagram description given in Figure 97-18.

During PMA training (TRAINING and COUNTDOWN states in Figure 97–18), PHY Control information is exchanged between link partners with a 12 octet InfoField, which is XOR’ed with the first 96 bits of the 15th partial RS FEC frame (bits 2520 to 2615) of the RS FEC frame. The InfoField is also denoted IF. The link partner is not required to decode every IF transmitted but is required to decode IFs at a rate that enables the correct actions prior to the PAM2 to PAM3 transition.

The 12 octet InfoField shall include the fields in 97.4.2.5.2 through 97.4.2.5.8, also shown in the overview Figure 97–13, and the more detailed Figure 97–14 and Figure 97–16. Each message shall be transmitted at least 256 times (<1msec) to ensure detection at link partner.

NOTE: This proposal eliminates message bits set_data_sw_pfc and ack_data_sw_pfc. set_data_sw_pfc is message is not necessary since PMA_state = 01 has the same meaning. ack_data_sw_pfc message is not necessary since it can be assumed the link partner received the set_data_sw_pfc message. A new Infofield format figure is added for the data mode scrambler seed.



Figure 97–13—InfoField format



Figure 97–14—InfoField TRAINING format

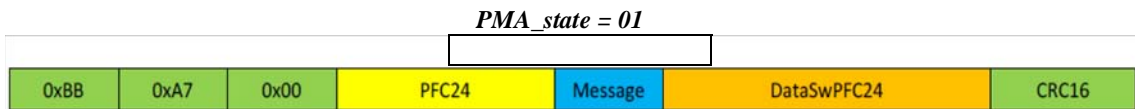

Figure 97–15—InfoField COUNTDOWN format



Figure 97–16—InfoField message exchange format

97.4.2.5.1 Infocfield notation

For all the InfoField notation below, Reserved<bit location> represents any unused values and shall be set to zero and ignored by the link partner. The InfoField is transmitted following the notation described in 97.3.2.2.3 where the LSB of each octet is sent first and the octets are sent in increasing number order (that is, the LSB of Oct1 is sent first).

97.4.2.5.2 Start of Frame Delimiter

The start of Frame Delimiter consists of 3 octets [Oct1<7:0>, Oct2<7:0>, Oct3<7:0>] and shall use the hexadecimal value 0xBBA700. 0xBB corresponds to Oct1<7:0> and so forth.

97.4.2.5.3 Partial Frame Count (PFC24)

The start of Partial Frame Count consists of 3 octets [Oct4<7:0>, Oct5<7:0>, Oct6<7:0>] and indicates the running count of partial RS FEC frames sent LSB first. There are 15 partial frames per RS FEC frame and the Infocfield is embedded within the 15th partial frame, thus the first partial frame count field after a reset is 15.

97.4.2.5.4 Message Field

Message Field (1 octet). For the MASTER, this field is represented by Oct7{PMA_state<7:6>, loc_rcvr_status<5>, en_slave_tx<4>, reserved<3:0>}. For the SLAVE, this field is represented by Oct7{PMA_state<7:6>, loc_rcvr_status<5>, timing_lock_OK<4>, reserved<3:0>}.

The two state-indicator bits PMA_state<7:6> shall communicate the state of the transmitting transceiver to the link partner. PMA_state<7:6>=00 indicates TRAINING, and PMA_state<7:6>=01 indicates COUNT-DOWN.

All possible Message Field settings are listed in Table 97–5 for the MASTER and Table 97–6 for the SLAVE. Any other value shall not be transmitted and shall be ignored at the receiver. The Message Field setting for the first transmitted PMA frame shall be the first row of Table 97–5 for the MASTER and the first row of Table 97–6 for the SLAVE. Moreover, for a given Message Field setting, the following Message Field setting shall be the same Message Field setting or the Message Field setting corresponding to a row below the current setting. When loc_rcvr_status=OK the InfoField variable is set to loc_rcvr_status<5>=1 and set to 0 otherwise.

1
2
3
4
5
6
7
8
9
10
11
12
13
14
15
16
17
18
19
20
21
22
23
24
25
26
27
28
29
30
31
32
33
34
35
36
37
38
39
40
41
42
43
44
45
46
47
48
49
50
51
52
53
54

Table 97-5—InfoField message field valid MASTER settings

PMA_state<7:6>	loc_rcvr_status	en_slave_tx	reserved	reserved	reserved	reserved
00	0	0	0	0	0	0
00	0	1	0	0	0	0
00	1	1	0	0	0	0
01	1	1	0	0	0	0

Table 97-6—InfoField message field valid SLAVE settings

PMA_state<7:6>	loc_rcvr_status	timing_lock_OK	reserved	reserved	reserved	reserved
00	0	0	0	0	0	0
00	0	1	0	0	0	0
00	1	1	0	0	0	0
01	1	1	0	0	0	0

97.4.2.5.5 Data Mode Scrambler Seed

When PMA_state<7:6>=00, [Oct8<7:0>, Oct9<7:0>, Oct10<7:0>] contains the data mode scrambler seed (Seed) containing bits S14 (sent first) to S0 (sent last) to indicate the initial state of data mode transmit scrambler of the local device upon reaching the data switch partial frame count. The state of the scrambler in Figure 97-7 will be S14:S0 at the first bit of the first RS FEC frame when DataSwPFC24 = 0, see 97.4.2.5.6. The format of Seed is Oct8<7:0> = S<7:14>, Oct9<7> = 0, Oct9<6:0> = S<0:6>, Oct10<7:0> = 0 and shall not be all zeros. Each octet is sent LSB first.

97.4.2.5.6 Data Switch Partial Frame Count

When PMA_state<7:6>=01, [Oct8<7:0>, Oct9<7:0>, Oct10<7:0>] contains the data switch partial frame count (DataSwPFC24) sent LSB first. DataSwPFC24 indicates the partial frame count when the transmitter switches from PAM2 to PAM3 which occurs at the start of a RS FEC block. The last value of PFC24 prior to the transition is DataSwPFC24 - 1.

97.4.2.5.7 Reserved Fields

When PMA_state<7:6> is greater than 01, [Oct8<1:0>, Oct9<1:0>, Oct10<7:0>] contains a reserved field. All InfoField fields denoted Reserved are reserved for future use.

97.4.2.5.8 CRC16

CRC16 (2 octets). Shall implement the CRC16 polynomial $(x+1)(x^{15}+x+1)$ of the previous 7 octets, Oct4<7:0>, Oct5<7:0>, Oct6<7:0>, Oct7<7:0>, Oct8<7:0>, Oct9<7:0>, and Oct10<7:0>. The CRC16 shall

1
2
3
4
5
6
7
8
9
10
11
12
13
14
15
16
17
18
19
20
21
22
23
24
25
26
27
28
29
30
31
32
33
34
35
36
37
38
39
40
41
42
43
44
45
46
47
48
49
50
51
52
53
54

produce the same result as the implementation shown in Figure 97–17. In Figure 97–17 the 16 delay elements S_0, \dots, S_{15} , shall be initialized to zero. Afterwards Oct5 through Oct10 are used to compute the CRC16 with the switch connected, which is setting CRCgen in Figure 97–17. After all the 7 octets have been processed, the switch is disconnected (setting CRCout) and the 16 values stored in the delay elements are transmitted in the order illustrated, first S_{15} , followed by S_{14} , and so on, until the final value S_0 .

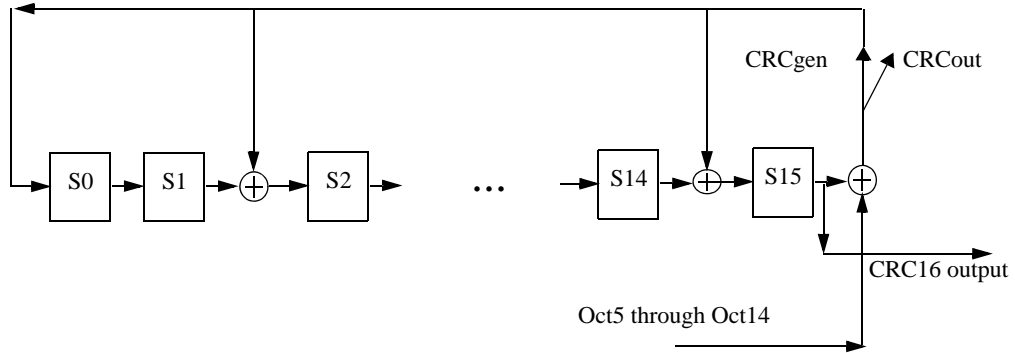

Figure 97–17—CRC16

1
2
3
4
5
6
7
8
9
10
11
12
13
14
15
16
17
18
19
20
21
22
23
24
25
26
27
28
29
30
31
32
33
34
35
36
37
38
39
40
41
42
43
44
45
46
47
48
49
50
51
52
53
54

97.4.2.5.9 Startup sequence

The startup sequence shall comply with the state diagram description given in Figure 97–18.

During Auto-Negotiation, PHY Control is in the DISABLE_1000BASE-T1_TRANSMITTER state and the transmitters are disabled.

When the Auto-Negotiation process asserts link_control=ENABLE PHY Control enters the INIT_MAXWAIT_TIMER state. Upon entering this state the maxwait_timer is started.

PHY Control then transition to the SILENT state. Upon entering this state the minwait_timer is started and the PHY transmits zeros (tx_mode=SEND_Z).

In MASTER mode PHY Control immediately transitions to the TRAINING state.

Upon entering the TRAINING state, the minwait_timer is started and the PHY Control forces transmission into the training mode by asserting tx_mode=SEND_T, which includes the transmission of InfoFields. The PHY Control also sets PMA_state = 00 and sends the Seed value used by the local device for data mode scrambler initialization, see 97.4.2.5.5.

Initially the MASTER is not ready for the SLAVE to respond and sets en_slave_tx=0, which is communicated to the link partner via the InfoField. After the MASTER has sufficiently converged the necessary circuitry, the MASTER must set en_slave_tx=1 to allow the SLAVE to transition to TRAINING.

In SLAVE mode, PHY Control transitions to the TRAINING state only after the SLAVE PHY acquires timing, converges its equalizers, acquires its descrambler state and sets loc_SNR_margin=OK.

Upon entering TRAINING state the SLAVE initially sets timing_lock_OK = 0 until it has acquired timing lock at which point the SLAVE sets timing_lock_OK = 1.

After the PHY completes successful training and establishes proper receiver operations, PCS Transmit conveys this information to the link partner via transmission of the parameter InfoField value loc_rcvr_status. The link partner's value for loc_rcvr_status is stored in the local device parameter rem_rcvr status. Upon expiration of the minwait_timer and when the condition loc_rcvr_status=OK and rem_rcvr_status=OK is satisfied, PHY control transitions to the COUNTDOWN state.

Upon entering the COUNTDOWN state, PHY Control sets PMA_state = 01, set_data_sw_pfc = 1 and DataSwPFC24 to the value of the partial frame count when the transmitter will switch from PAM2 to PAM3.

Upon reaching DataSwPFC24 partial frame count PHY Control transitions to the SEND_IDLE1 state and forces transmission into the idle mode by asserting tx_mode=SEND_I.

Once the link partner has reached transitioned from PAM2 to PAM3, PHY Control transitions to the SEND_IDLE2 state and starts the minwait_timer.

Upon expiration of the minwait_timer and when the condition loc_rcvr_status=OK and PCS_status=OK is satisfied, PHY control transitions to the SEND_DATA state.

Upon entering the SEND_DATA state, PHY Control stops the maxwait_timer, starts the minwait_timer and enables normal data transmission asserting tx_mode=SEND_N.

The operation of the maxwait_timer requires that the PHY complete the startup sequence from state INIT_MAXWAIT_TIMER to SEND_DATA in the PHY Control state diagram state diagram (Figure 97–18)

in less than 97.5 ms to avoid link_status being changed to FAIL by the Link Monitor state diagram (Figure 97–19).

97.4.2.6 Link Monitor function

Link Monitor determines the status of the underlying receive channel and communicates it via the variable link_status. Failure of the underlying receive channel typically causes the PMA's clients to suspend normal operation.

The Link Monitor function shall comply with the state diagram of Figure 97–19.

Upon power on, reset, or release from power down, the Auto-Negotiation algorithm sets link_control=DISABLE and sends half duplex Differential Manchester Encoded data to signal its presence to a remote station. If the presence of a remote station is sensed through reception of DME data, the Auto-Negotiation algorithm exchanges Auto-Negotiation information with the remote station. During this period, link_status=FAIL is asserted. If the presence of a remote 1000BASE-T1 station is established, the Auto-Negotiation algorithm permits full operation by setting link_control=ENABLE. As soon as reliable transmission is achieved, the variable link_status=OK is asserted, upon which further PHY operations can take place.

97.4.2.7 Clock Recovery function

The Clock Recovery function shall provide a clock suitable for signal sampling so that the RS FER indicated in 97.4.2.4 is achieved. The received clock signal should be stable and ready for use when training has been completed (loc_rcvr_status=OK). The received clock signal is supplied to the PMA Transmit function by received_clock.

97.4.3 MDI

Communication through the MDI is summarized in 97.4.3.1 and 97.4.3.2.

97.4.3.1 MDI signals transmitted by the PHY

The symbols to be transmitted by the PMA are denoted by tx_symb. The modulation scheme used over each pair is PAM3. PMA Transmit generates a pulse-amplitude modulated signal on each pair in the following form:

$$s(t) = \sum_{n=0}^{\infty} a_n h_T(t - nT) \quad (55-3)$$

In Equation (55–3), a_n is the PAM3 modulation symbol from the set $\{-1, 0, 1\}$ to be transmitted at time nT , and $h_T(t)$ denotes the system symbol response at the MDI. This symbol response shall comply with the electrical specifications given in 97.5.

97.4.3.2 Signals received at the MDI

Signals received at the MDI can be expressed for each pair as pulse-amplitude modulated signals that are corrupted by noise as follows:

$$r(t) = \sum_{n=0}^{\infty} a_n h_R(t - nT) + w(t) \quad (55-4)$$

In Equation (55–4) $h_R(t)$ denotes the symbol response of the overall channel impulse response between the transmit symbol source and the receive MDI and $w(t)$ represents the contribution of various noise sources

including uncanceled echo. The receive signal is processed within the PMA Receive function to yield the received symbols rx_symb.

97.4.4 State variables

97.4.4.1 State diagram variables

config

The PMA shall generate this variable continuously and pass it to the PCS via the PMA_CONFIG.indication primitive.
Values: MASTER or SLAVE

en_slave_tx

The en_slave_tx variable in the InfoField received by the slave.
Values: 0: Master is not ready for the slave to transmit.
1: Master is ready for the slave to transmit.

link_control

This variable is defined in 98.5.1

link_status

The link_status parameter set by PMA Link Monitor and passed to the PCS via the PMA_LINK.indication primitive.
Values: OK or FAIL

loc_rcvr_status

Variable set by the PMA Receive function to indicate correct or incorrect operation of the receive link for the local PHY. This variable is transmitted in the loc_rcvr_status bit of the InfoField by the local PHY.
Values: OK: The receive link for the local PHY is operating reliably.
NOT_OK: Operation of the receive link for the local PHY is unreliable.

loc_SNR_margin

This variable reports whether the local device has sufficient SNR margin to continue to the next state. The criterion for setting the parameter loc_SNR_margin is left to the implementor.
Values: OK: The local device has sufficient SNR margin.
NOT_OK: The local device does not have sufficient SNR margin.

pma_reset

Allows reset of all PMA functions.
Values: ON or OFF
Set by: PMA Reset

PMA_state

Variable for the value transmitted in the PMA_state<7:6> of the InfoField by the local PHY
Values: 00: TRAINING state.
01: COUNTDOWN state.

PMA_watchdog_status

Variable indicating the status of the PAM3 monitor.
During normal operation:
PAM3 symbol 0 consecutively seen on the line for longer than 2us +/- 0.1us
PAM3 symbol +1 consecutively seen on the line for longer than 3.9us +/- 0.1us
PAM3 symbol -1 consecutively seen on the line for longer than 3.9us +/- 0.1us

During Low Power Idle operation:	1
PAM3 symbol not toggling on the line for longer than 90us +/- 0.1us	2
Values: OK: The local device has received sufficient PAM3 transitions.	3
NOT_OK: The local device has not received sufficient PAM3 transitions.	4
	5
rem_rcvr_status	6
Variable set by the PCS Receive function to indicate whether correct operation of the receive link for the remote PHY is detected or not. This variable is received in the loc_rcvr_status bit in the InfoField from the remote PHY.	7
Values: OK: The receive link for the remote PHY is operating reliably.	8
NOT_OK: Reliable operation of the receive link for the remote PHY is not detected.	9
	10
	11
	12
tx_mode	13
PCS Transmit sends code-groups according to the value assumed by this variable.	14
Values: SEND_N: This value is continuously asserted when transmission of sequences of code-groups representing a GMII data stream take place.	15
SEND_I: This value is continuously asserted when transmission of sequences of code-groups representing a idle stream take place.	16
SEND_T: This value is continuously asserted when transmission of sequences of code-groups representing the training sequences of code-groups is to take place.	17
SEND_Z: This value is asserted when transmission of zero code-groups is to take place.	18
	19
	20
	21
	22
	23
97.4.4.2 Timers	24
	25
All timers operate in the manner described in 14.2.3.2.	26
	27
maxwait_timer	28
A timer used to limit the amount of time during which a receiver dwells in the SILENT and TRAINING states. The timer shall expire 97.5 ms ± 0.5 ms after being started. This timer is used jointly in the PHY Control and Link Monitor state diagrams. The maxwait_timer is tested by the Link Monitor to force link_status to be set to FAIL if the timer expires and loc_rcvr_status, PCS_state or PMA_watchdog_status is NOT_OK. See Figure 97–18 and Figure 97–19.	29
	30
	31
	32
	33
	34
	35
minwait_timer	36
A timer used to determine the minimum amount of time the PHY Control stays in the SILENT, TRAINING, SEND IDLE1 and SEND IDLE2 states. The timer shall expire 975us ± 50 us after being started.	37
	38
	39
	40
	41
	42
	43
	44
	45
	46
	47
	48
	49
	50
	51
	52
	53
	54

97.4.5 State diagrams

97.4.5.1 PHY Control state diagram

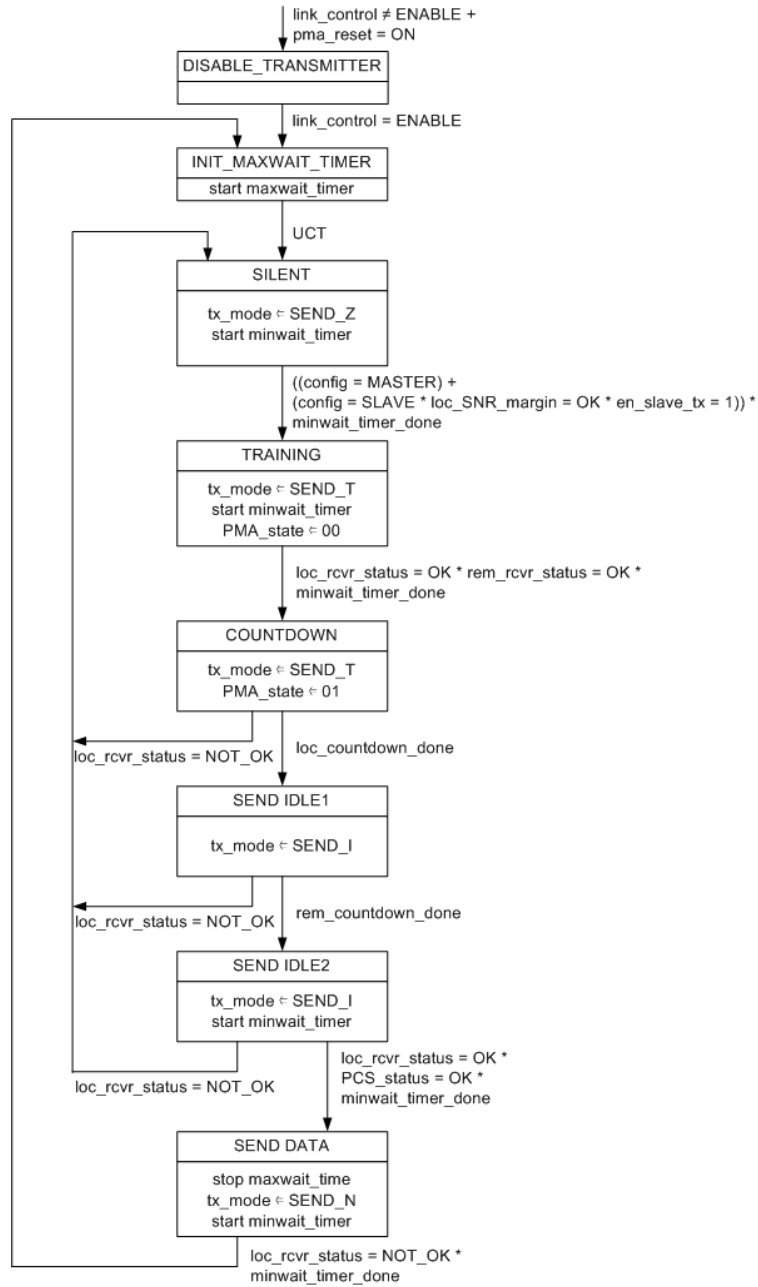
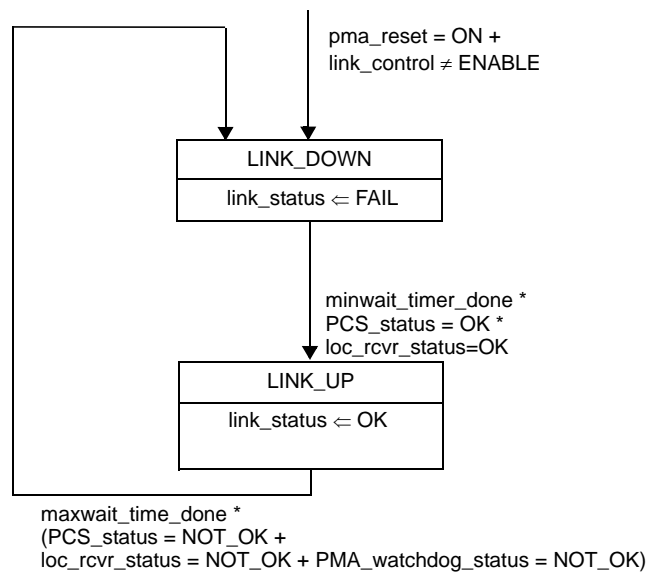

Figure 97–18—PHY Control state diagram

1
2
3
4
5
6
7
8
9
10
11
12
13
14
15
16
17
18
19
20
21
22
23
24
25
26
27
28
29
30
31
32
33
34
35
36
37
38
39
40
41
42
43
44
45
46
47
48
49
50
51
52
53
54

97.4.5.2 Link Monitor state diagram



NOTE 1—`maxwait_timer` is started in PHY Control state diagram (see Figure 97–18).
NOTE 2—The variables `link_control` and `link_status` are designated as `link_control_1GigT1` and `link_status_1GigT1`, respectively, by the Auto-Negotiation Arbitration state diagram (Figure 98–14).

Figure 97–19—Link Monitor state diagram

1
2
3
4
5
6
7
8
9
10
11
12
13
14
15
16
17
18
19
20
21
22
23
24
25
26
27
28
29
30
31
32
33
34
35
36
37
38
39
40
41
42
43
44
45
46
47
48
49
50
51
52
53
54