

PAM2 Training States and InfoField for 1000BASE-T1

San Antonio, TX, USA
November 4, 2014

Mike Tu
tum@broadcom.com

Contributors

- Jane Fridley
- Peiqing Wang
- Ahmad Chini
- Mehmet Tazebay

Overall Startup Sequence

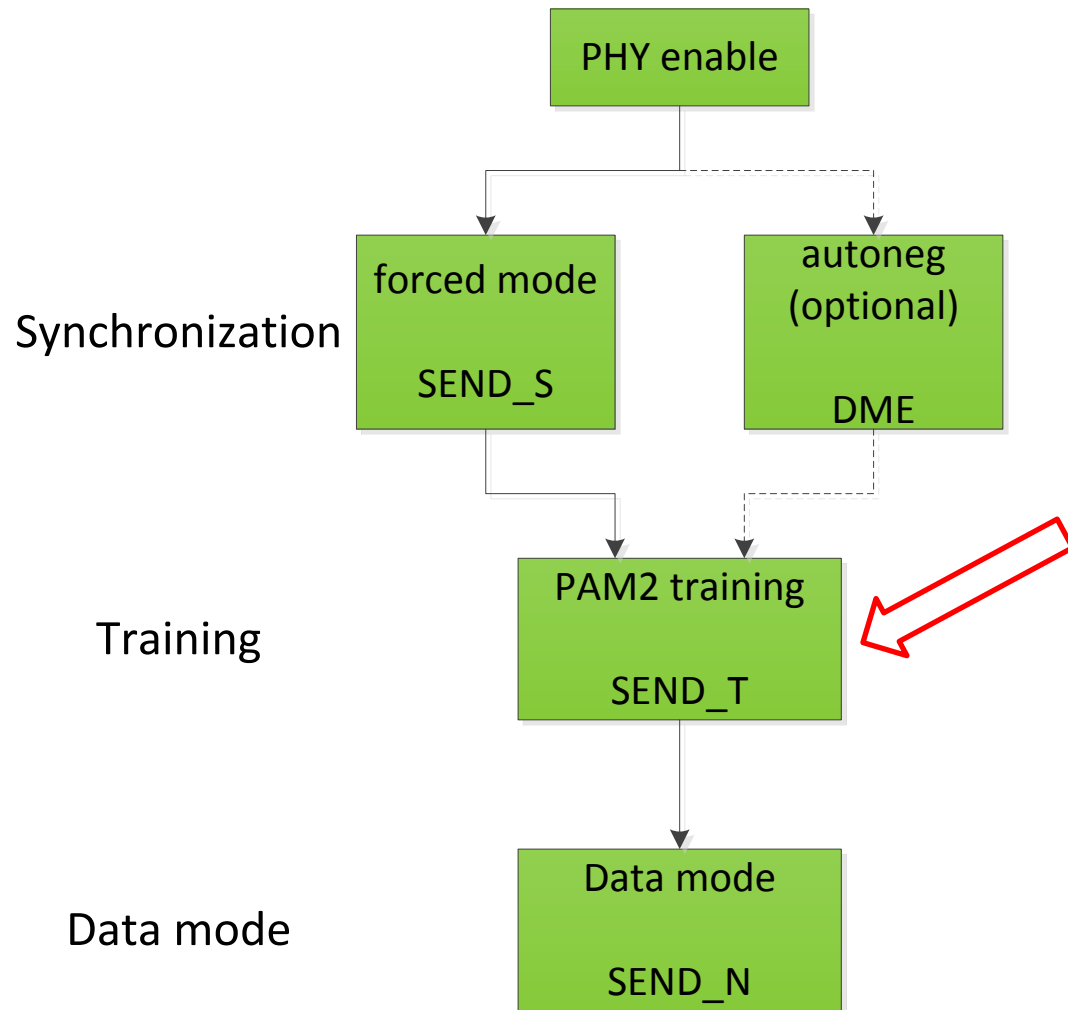

TX Mode	Definition
SEND_Z	Send all zeros
DME	Differential Manchester encoding for autoneg
SEND_S	Send special periodic PAM2 sequences with good correlation properties
SEND_T	Send PAM2 training sequence
SEND_N	Send normal data

Outline

- Adopted from prior proposal
 - PAM2 training frame is 3.6usec, aligned with data mode FEC frame
 - InfoField per PAM2 training frame
 - One bit inversion every 240nsec (i.e., 180 PAM2 symbols)
 - “Partial RS Frame Count” (PFC) within InfoField, incremented by 15 per frame
 - See “Lo_3bp_01a_0914”
- Proposed changes
 - State transitions based on InfoField message exchanges and PFC counts
 - Move InfoField to the end of frame
 - Increase InfoField to 96 bits to support message exchanges
 - Increase PFC to 24 bits to avoid wrap-around ambiguity
 - Exchange data mode scrambler initial state and starting time (via PFC)
 - Define valid InfoField messages

Frame Format in PAM2 Training Mode

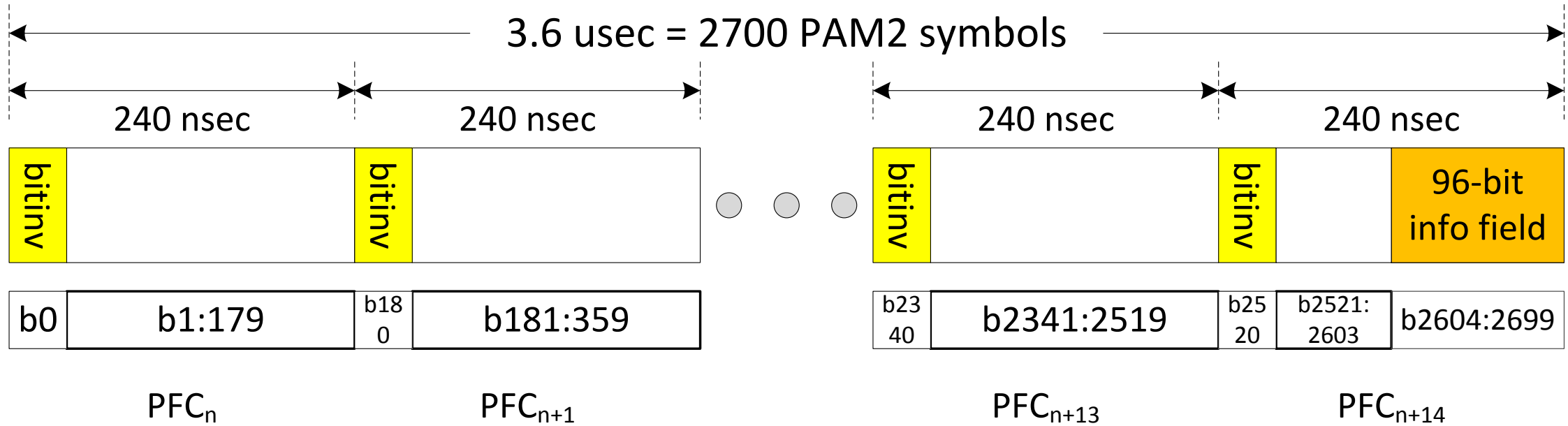

PAM2 Training Sequence

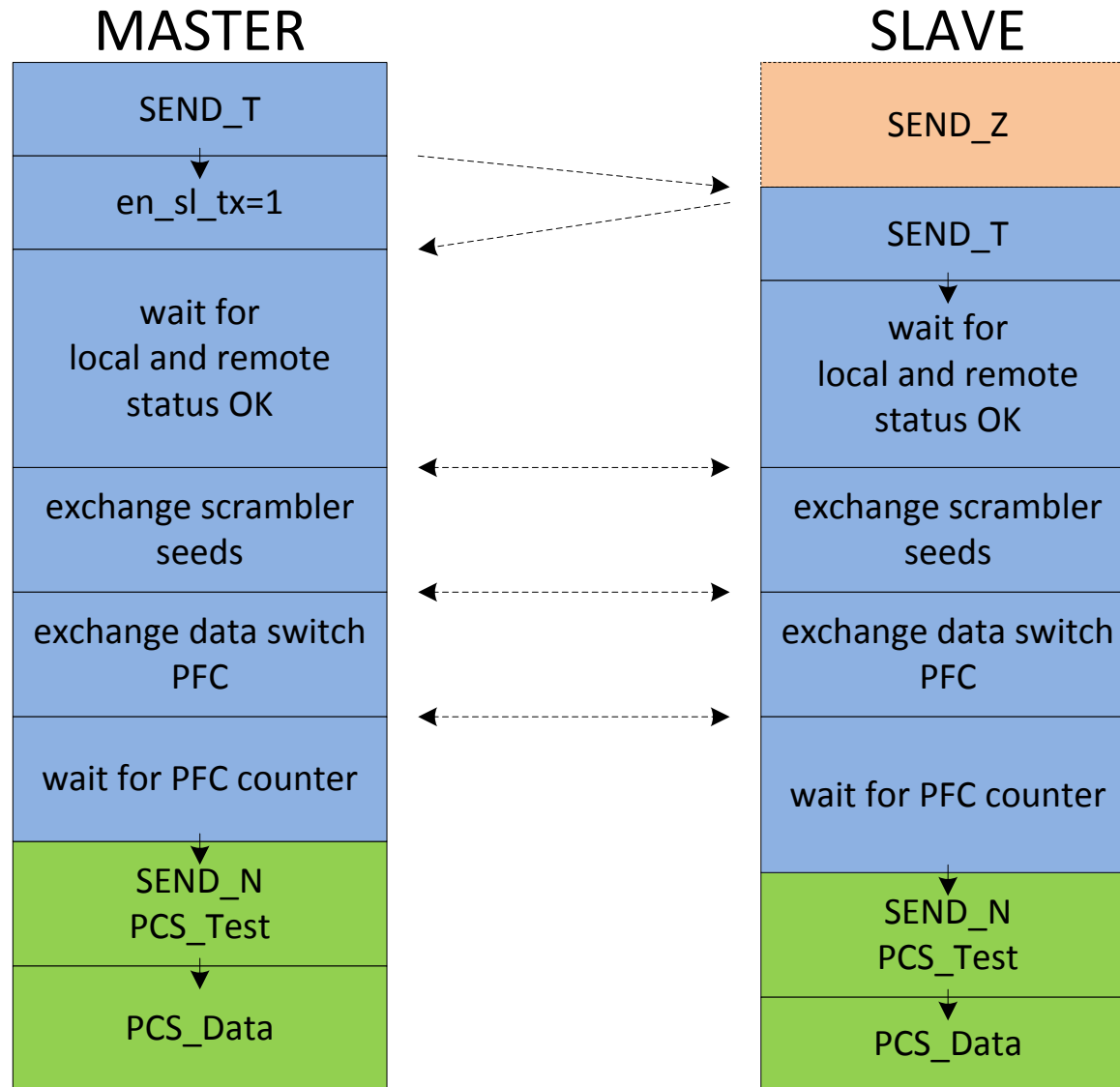

- PAM2 state transition based on InfoField message exchanges.
- Send and acknowledge data mode scrambler seeds, and PFC24 counts when switching into data mode.

96-bit InfoField Format

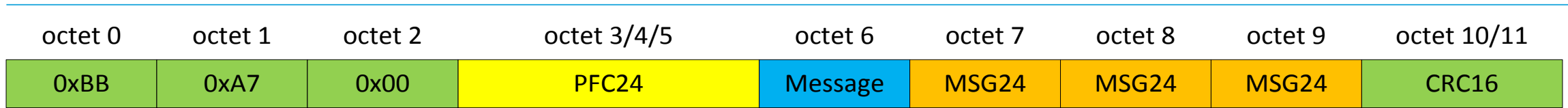

Id_scr_seed = 1



set_data_sw_pfc = 1



all others



- PFC24 incremented by 15 per frame.
- Each message lasts at least 256 (TBD) frames (<1msec) to ensure detection at link partner.
- With 24-bit PFC it takes > 4 seconds without counter wrap-around ($2^{24} * 3.6 \text{ usec} / 15 = 4.0265 \text{ seconds}$).
- The “Id_scr_seed=1” message shall specify the initial state of the data mode side-stream scrambler. Filling up 24 LSB, and assuming MSB (if any) are 0.
- The “set_data_sw_pfc=1” message shall specify the exact time to switch into data mode.

Valid InfoField Messages – MASTER

PMA states	InfoField message field valid MASTER settings						
	PMA_state <7:6>	loc_rcvr_status	en_slave_tx	ld_scr_seed	ack_scr_seed	set_data_sw_pfc	ack_data_sw_pfc
PMA_Train_Init_M	00	0	0	0	0	0	0
PMA_Train_Init_M	00	0	1	0	0	0	0
PMA_Train_Init_M	00	1	1	0	0	0	0
PMA_ScrSeed_Exchange	01	1	1	1	0	0	0
PMA_ScrSeed_Exchange	01	1	1	0	1	0	0
PMA_ScrSeed_Exchange	01	1	1	1	1	0	0
PMA_DataSwPfc_Exchange	10	1	1	0	1	1	0
PMA_DataSwPfc_Exchange	10	1	1	0	1	0	1
PMA_DataSwPfc_Exchange	10	1	1	0	1	1	1
PMA_Sw_to_Data	11	1	1	0	1	0	1

- Definition of “loc_rcvr_status” is different from 10GBASE-T. Might need a different name.

Valid InfoField Messages – SLAVE

PMA states	InfoField message field valid SLAVE settings						
	PMA_state <7:6>	loc_rcvr_status	timing_lock_OK	ld_scr_seed	ack_scr_seed	set_data_sw_pfc	ack_data_sw_pfc
PMA_Train_Init_S	00	0	0	0	0	0	0
PMA_Train_Init_S	00	0	1	0	0	0	0
PMA_Train_Init_S	00	1	1	0	0	0	0
PMA_ScrSeed_Exchange	01	1	1	1	0	0	0
PMA_ScrSeed_Exchange	01	1	1	0	1	0	0
PMA_ScrSeed_Exchange	01	1	1	1	1	0	0
PMA_DataSwPfc_Exchange	10	1	1	0	1	1	0
PMA_DataSwPfc_Exchange	10	1	1	0	1	0	1
PMA_DataSwPfc_Exchange	10	1	1	0	1	1	1
PMA_Sw_to_Data	11	1	1	0	1	0	1

State Transition Rules

- Each state shall last at least 256 (TBD) frames (<1msec) to ensure detection at link partner.
- Initial training
 - SLAVE remains silent until it receives “en_slave_tx=1”.
 - SLAVE sets “timing_lock_OK=1” after convergence.
 - (TBD) After both sides report “loc_rcvr_status=1”, either MASTER or SLAVE can initiate exchanges of scrambler seeds and data switch PFC counts.
- Message exchanges
 - Receive side shall set “ack_scr_seed=1” once it detects “ld_scr_seed=1” message.
 - Receive side shall set “ack_data_sw_pfc=1” once it detects “set_data_sw_pfc” message.
- Entering data mode
 - Transition from PAM2 training SEND_T mode into data SEND_N mode is based on the received PFC24 counter value.
 - The data mode descrambler shall start with the received ScrSeed24 at the beginning of the specified PFC24 count.