Annex: Alien Crosstalk Test Procedure

**Chris DiMinico MC Communications/Panduit
cdiminico@ieee.org**

Annex: Alien Crosstalk Test Procedure

This Annex describes a procedure for measuring ANEXT loss and AFEXT loss between pairs of adjacent link segments consisting of cables and in-line connectors. The procedure is required to assess the alien crosstalk performance of the link segments as specified in 98.4.4.3 Coupling parameters between type A link segments and 98.4.4.4 Coupling parameters between type B link segments. This procedure is intended for use in the laboratory, to evaluate that the link segments complies with the PSANEXT loss and PSAACRF requirements, when properly installed.

Alien crosstalk test configurations

Alien crosstalk coupled between type A link segments

The limits for PSANEXT and PSAACRF are based on the alien crosstalk test configuration in figures 1-4. The automotive link segment test configurations are derived from two automotive industry use cases representative of common scenarios. Measurements to be performed at 23 deg +/-5 deg C (TBD) relative humidity 25%-75% (TBD).

The use case 1 alien crosstalk test configuration consists of three link segments of 3 meter length and two inline connectors, equally spaced at 1 meter distance. Both single port and multiport test fixtures illustrated. The power sum ANEXT loss between a disturbed type A link segment and the disturbing type A link segments shall meet the values determined using Equation (98–7).

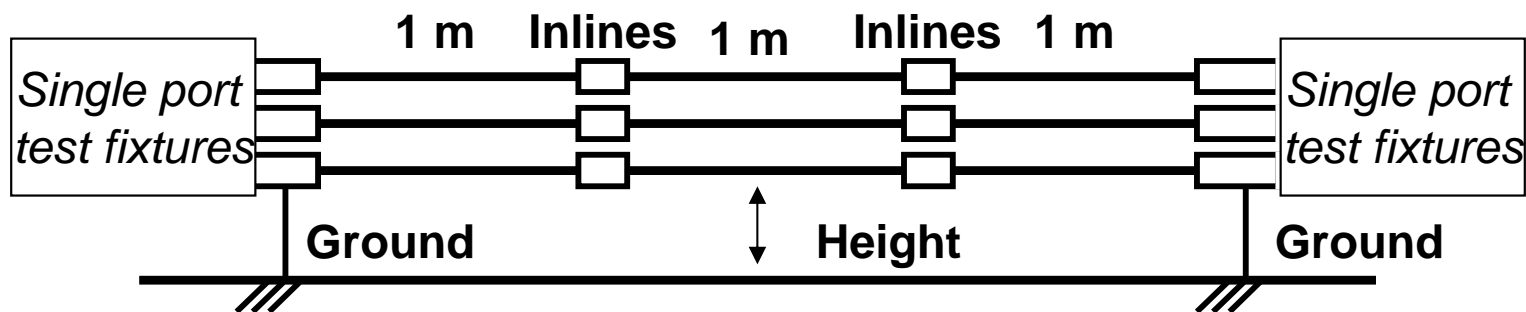

Figure 1. Alien crosstalk test configuration use case 1 single port

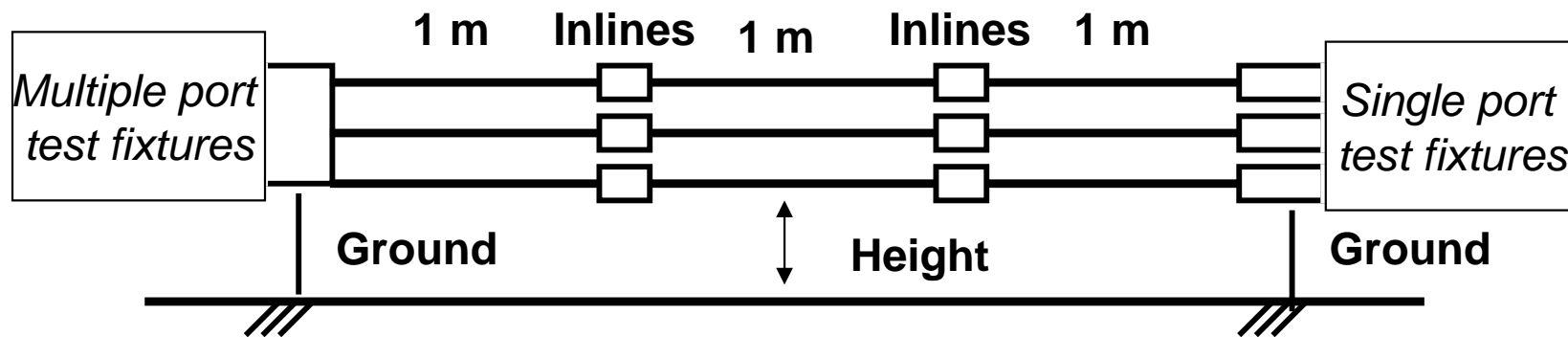

Figure 2. Alien crosstalk test configuration use case 1 multiple port

Alien crosstalk test configurations

Alien crosstalk coupled between type A link segments

The use case 2 alien crosstalk test configuration consists of 4 link segments bundled together over a 5 meter length with one of the link segments extending unbundled for 3 meters. The 3 meter unbundled section includes 2 inline connectors in addition to the 2 inline connectors in the 5 meter bundled section. The power sum ANEXT loss between any disturbed type A link segment and the disturbing type A link segments shall meet the values determined using Equation (98–7).

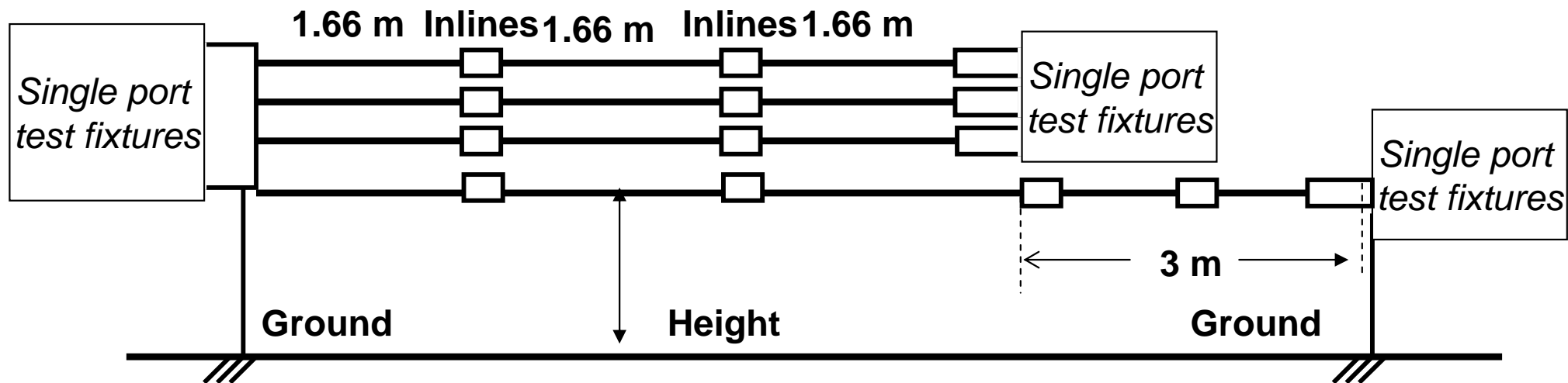

Figure 3. Alien crosstalk test configuration use case 2 single port

Alien crosstalk test configurations

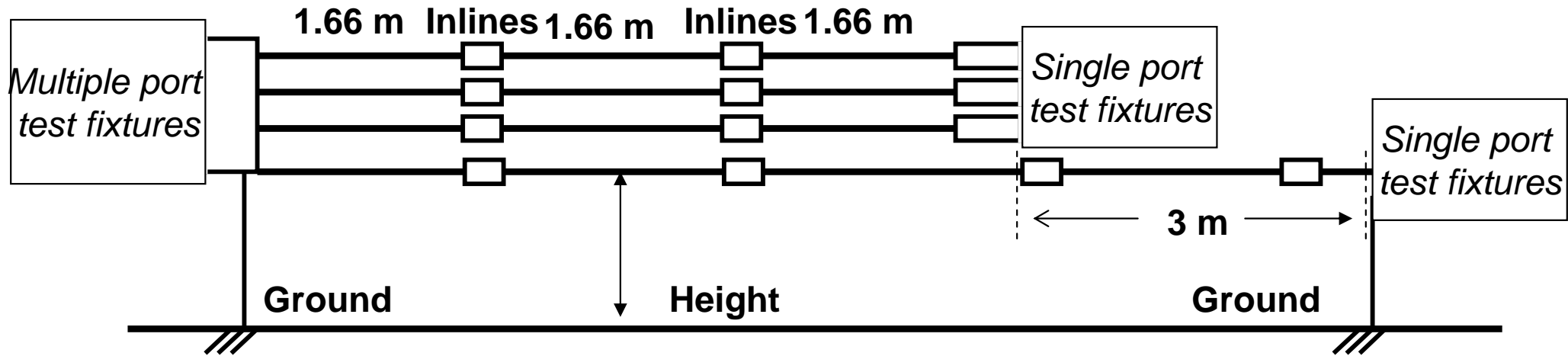
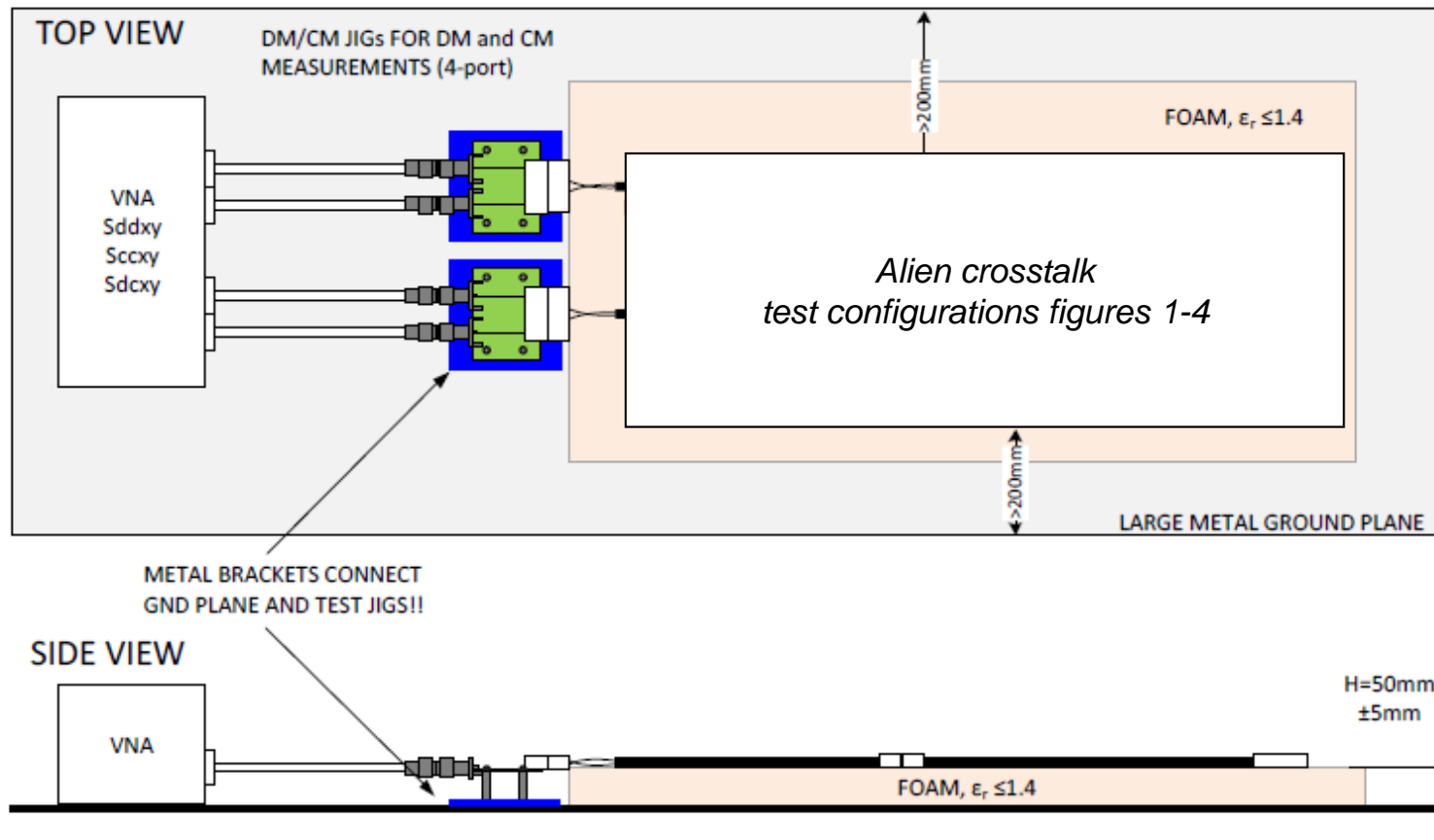

Figure 4. Alien crosstalk test configuration use case 2 multiple port

Alien crosstalk test configuration

The Alien crosstalk measurements are to be performed utilizing the test setup and methodology specified in Annex 98A.



Notes:

1. Two DM/CM jigs are used for all 4-port differential mode and common mode measurements.
2. Brackets provide reference "0V" for CM at the ends of DUT and VNA cables.
3. The entire setup is on a large metal GND plane, which extends at least 200mm beyond the setup.

Alien crosstalk test configurations

Cable bundling

The cable bundle shall be placed on dielectric insulation material ($\epsilon_r < 1.4$) of 50 mm height over conducting ground plane. The cables have to be placed within the alien crosstalk test configuration in a four around one configuration as shown in Figure 3.

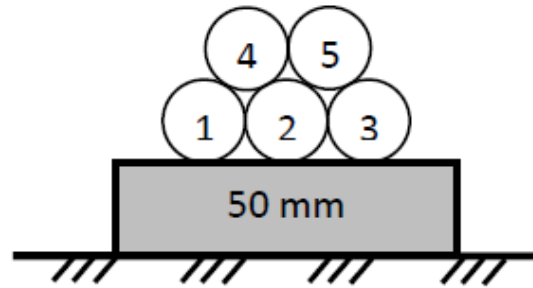

Figure 3: Cable bundle in four around one configuration

The cables should be fixed in their position by means of cable straps or adhesive tape to keep the cables attached together with a maximum distance between the fixation devices of 30 cm (t.b.d.).

The measurement fixtures have to be connected to the reference ground plane by means of conducting stands, copperbraid or –foil. Unused ports have to be terminated with a differential impedance of 100 Ω .

If it is necessary to split up the wiring harness at the end of the bundle in order to accommodate the measurement fixtures, the length of the area split up is limited to max. 30 cm (t.b.d.).