

1000BASE-T AutoNegotiation & Link Criteria

**IEEE 802.3ab Meeting
San Jose, California**

**Kishan R. Konda, Level One, kishan@level1.com
Mark T. Feuerstraeter, Level One, mark@level1.com**



1

February 12-13, 1998
IEEE 802.3ab Interim
San Jose, California

OVERVIEW

- 1000BASE-T AutoNegotiation Using Next Page
- HCD and Master-Slave Resolution
- 1000BASE-TX Link Criteria
- Review Of 100BASE-T Link Criteria



2

February 12-13, 1998
IEEE 802.3ab Interim
San Jose, California

1000BASE-T AutoNegotiation

- Utilizes/requires existing Autonegotiation mechanism already defined in clause 28
- Utilizes/requires next page function already defined in clause 28
- Fully backwards compatible with all previous 10/100 autonegotiation devices
- Adds one message page and two unformatted pages of information
- Adds two additional registers (9 and 10)-shared with 100Base-T2
- 1000Base-T message exchange does not require external processor intervention



1000BASE-T Auto Negotiation

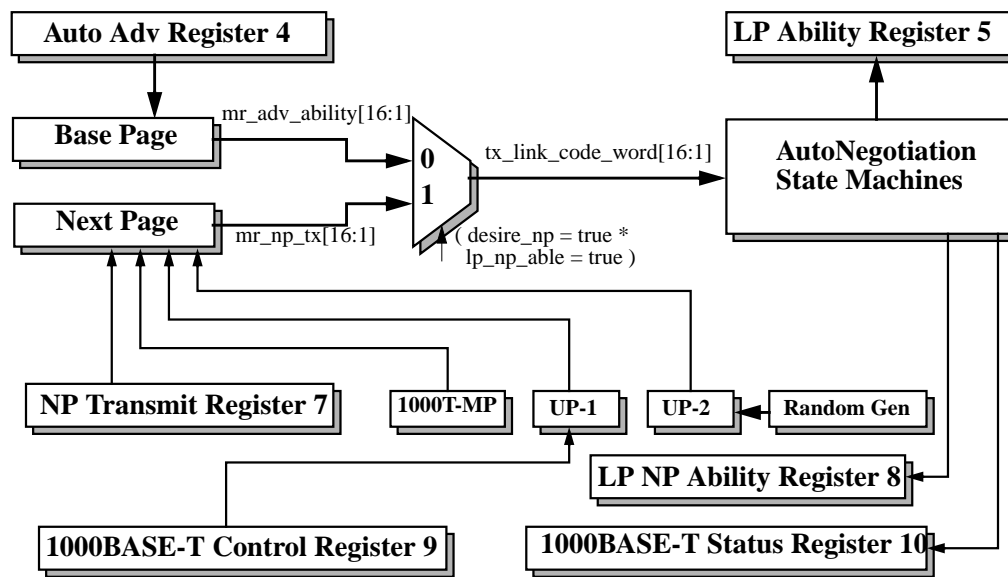

Next Page Transmit Register (Address 7)

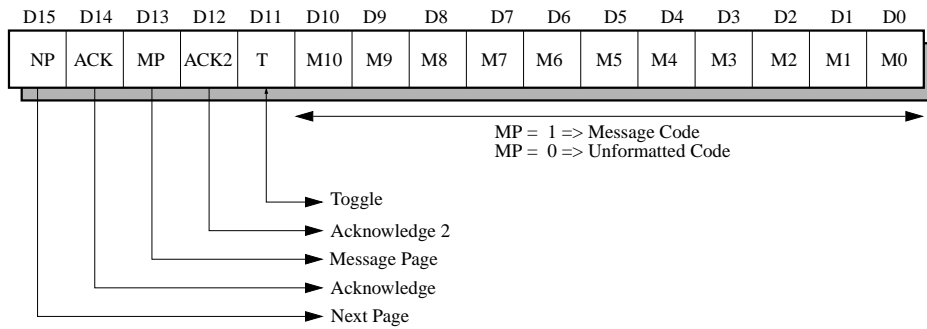

5

February 12-13, 1998
IEEE 802.3ab Interim
San Jose, California



LP Next Page Ability Register (Address 8)

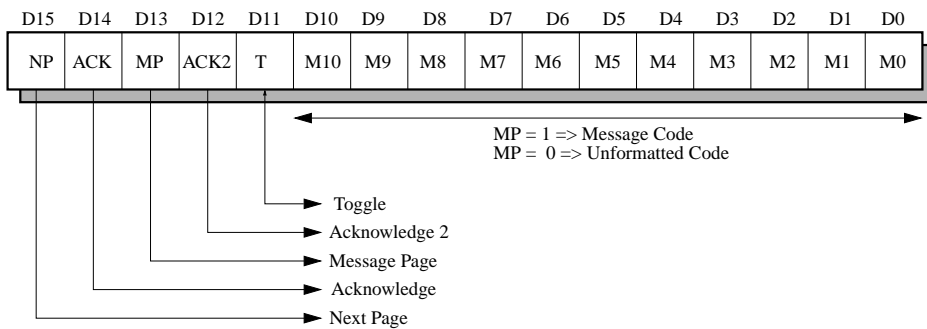

6

February 12-13, 1998
IEEE 802.3ab Interim
San Jose, California



1000BASE-T Control Register (Address 9)

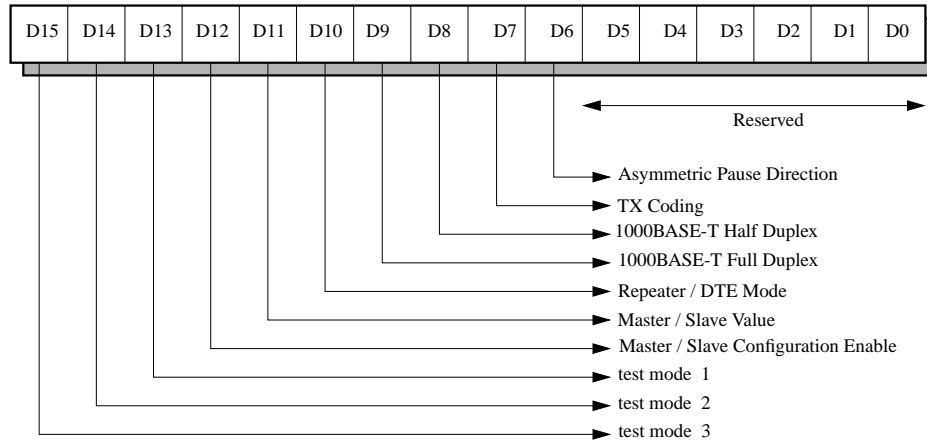

7

February 12-13, 1998
IEEE 802.3ab Interim
San Jose, California



1000BASE-T Status Register (Address 10)

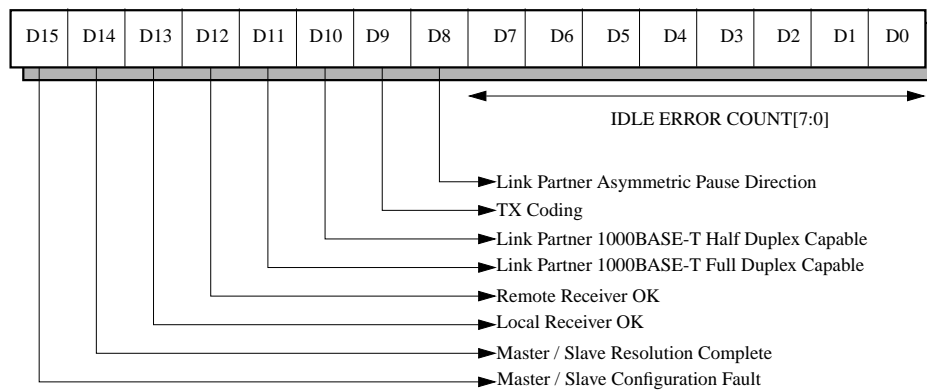

8

February 12-13, 1998
IEEE 802.3ab Interim
San Jose, California



1000BASE-T AutoNegotiation

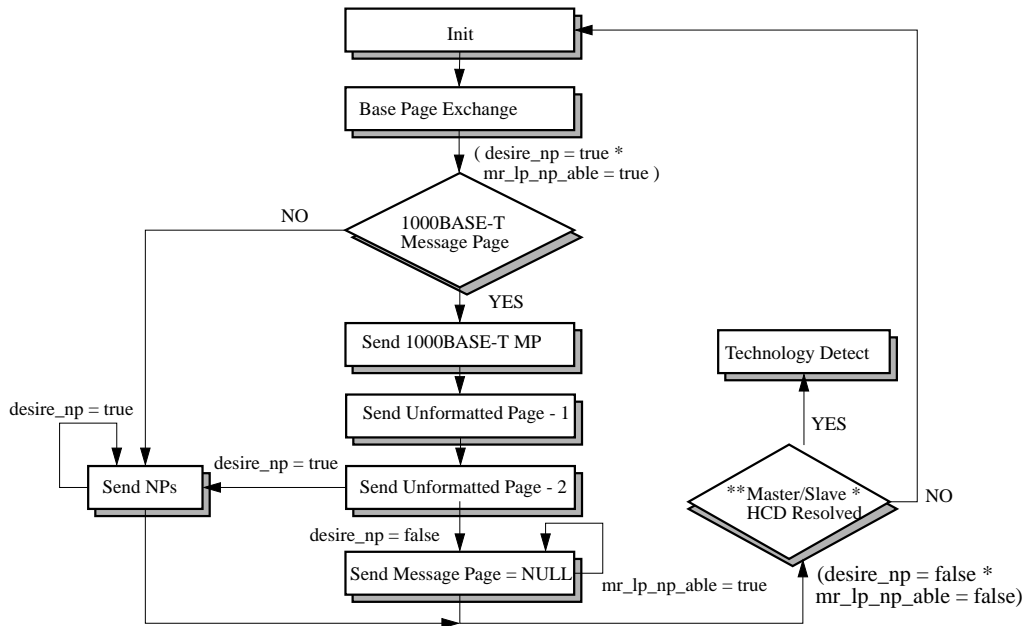

Note: Software is responsible for NULL Page if additional NPs are sent. ** Only valid if the HCD is 1000T else pass

9

February 12-13, 1998
IEEE 802.3ab Interim
San Jose, California



1000BASE-T Message Page

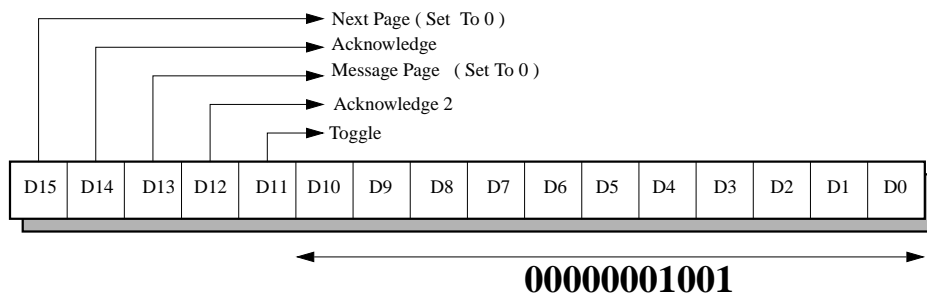

10

February 12-13, 1998
IEEE 802.3ab Interim
San Jose, California



Unformatted Page - 1 Encoding

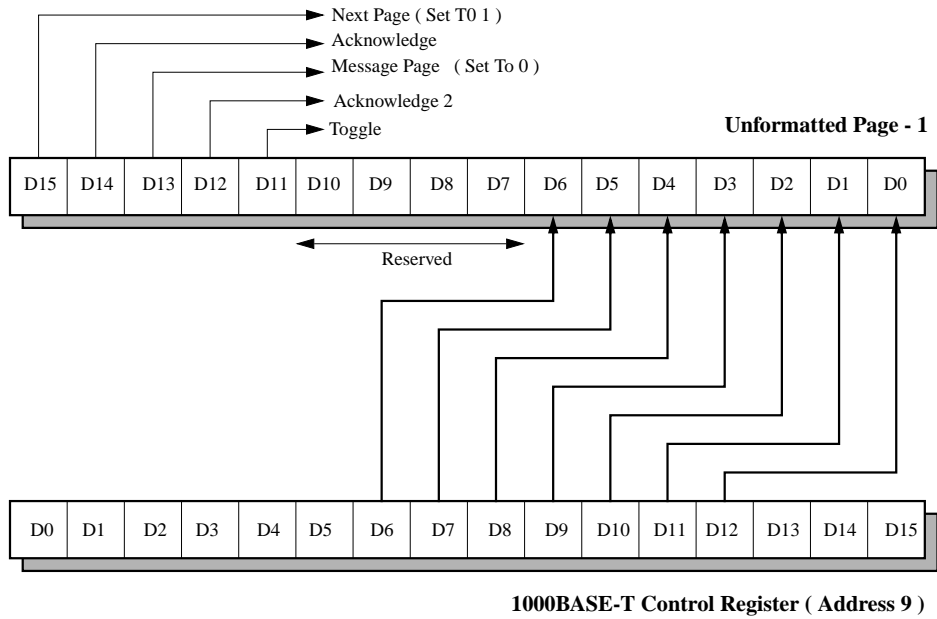

11

February 12-13, 1998
IEEE 802.3ab Interim
San Jose, California



Unformatted Page - 2 Encoding

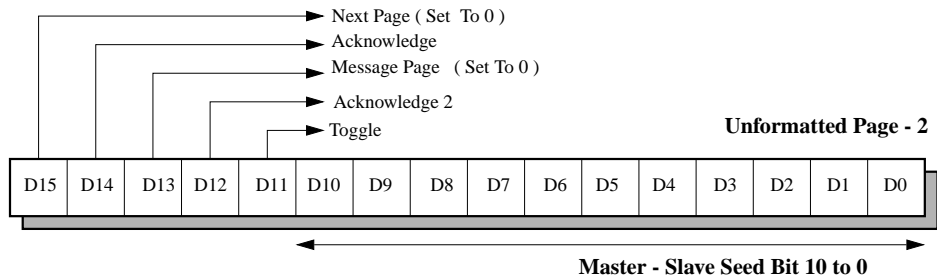

12

February 12-13, 1998
IEEE 802.3ab Interim
San Jose, California



HCD Resolution

- Highest Common Denominator is determined using the following Priority Table.

Table 1: Priority Table

Priority Level	Technology
a ** (Highest)	100BASE-T Full Duplex
b	100BASE-T Half Duplex
c	100BASE-T2 Full Duplex
d	100BASE-TX Full Duplex
e	100BASE-T2 Half Duplex
f	100BASE-T4
g	100BASE-TX Half Duplex
h	10BASE-T Full Duplex
i (Lowest)	10BASE-T Half Duplex

Master-Slave Resolution

Table 2: 100BASE-T MASTER-SLAVE Resolution

		Resolution	Resolution
Local Device Type	Remote Device Type	Local Device	Remote Device
DTE	Repeater	SLAVE	MASTER
Manual Slave	Manual Master	SLAVE	MASTER
Repeater	Manual Master	SLAVE	MASTER
Manual Slave	DTE	SLAVE	MASTER
Repeater	DTE	MASTER	SLAVE
Manual Master	Manual Slave	MASTER	SLAVE
DTE	Manual Slave	MASTER	SLAVE
Manual Master	Repeater	MASTER	SLAVE
Repeater	Repeater	The higher SEED value is configure as MASTER, otherwise SLAVE	The higher SEED value is configure as MASTER, otherwise SLAVE
DTE	DTE	The higher SEED value is configure as MASTER, otherwise SLAVE	The higher SEED value is configure as MASTER, otherwise SLAVE
Manual Slave	Manual Slave	MASTER-SLAVE Resolution Fault	MASTER-SLAVE Resolution Fault
Manual Master	Manual Master	MASTER-SLAVE Resolution Fault	MASTER-SLAVE Resolution Fault

1000BASE-T Link Criteria

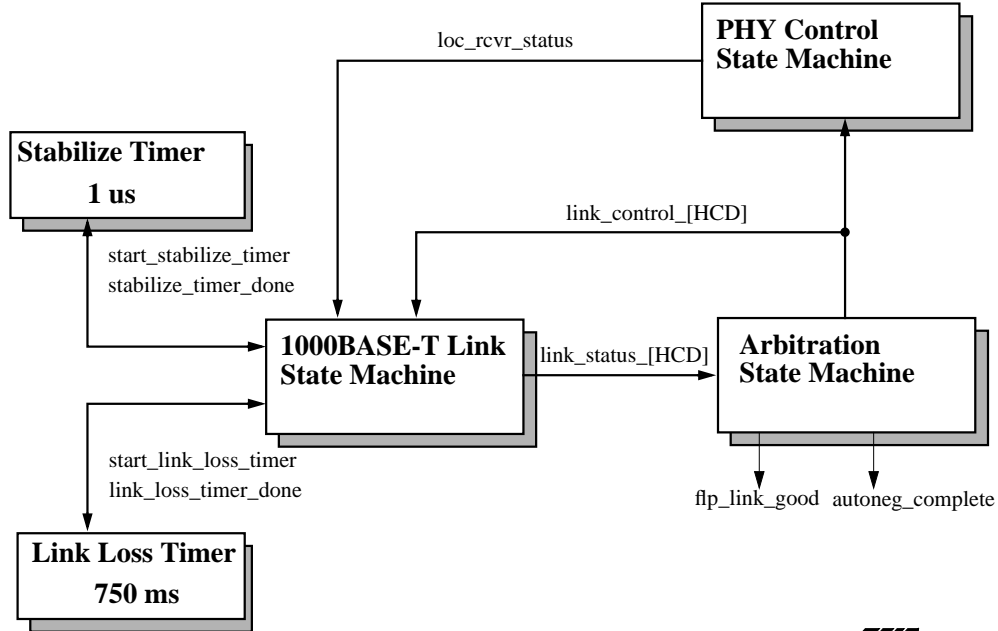

15

February 12-13, 1998
IEEE 802.3ab Interim
San Jose, California



1000BASE-T Link Criteria (continued)

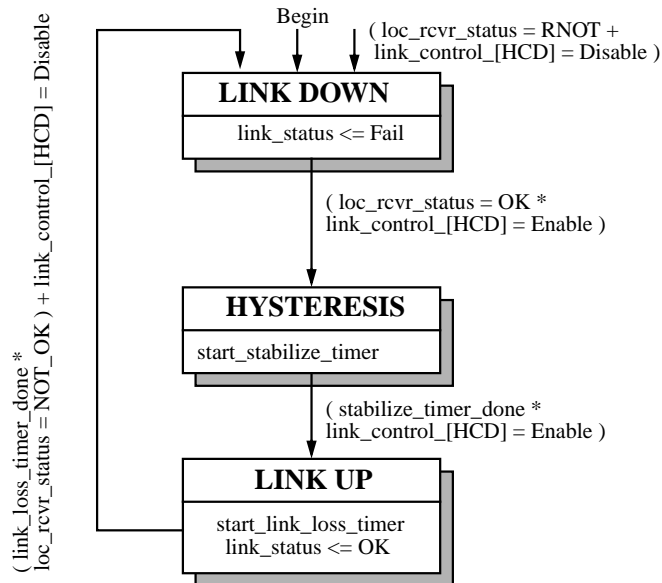

16

February 12-13, 1998
IEEE 802.3ab Interim
San Jose, California



Review Of 100BASE-TX Link Criteria

