

10Gb/s PMD Using PAM-5 Trellis Coded Modulation

Oscar Agazzi, Nambi Seshadri, Gottfried Ungerboeck
Broadcom Corp.
16215 Alton Parkway
Irvine, CA 92618



Goals

- **Achieve distance objective of 300m over existing MMF**
- **Operate with single channel optoelectronic (single laser and single photodetector)**
- **Achieve single chip low cost CMOS PHY solution with Hari interface**



Approach

- **Utilize PAM-5 signaling at 5GBaud**
- **Assume standard 62.5/125 μ m fiber with bandwidth of 160/500MHz-Km**
- **Use adaptive equalization to compensate for intersymbol interference introduced by bandwidth limited MMF**
 - Assumption is that a 300m MMF is bandwidth limited to 1GHz at 1310nm
 - A nonlinear equalizer can compensate for laser nonlinearity
- **Adaptive equalizer tracks the variations of laser and fiber response over time**



Simplified Diagram of Transmission System

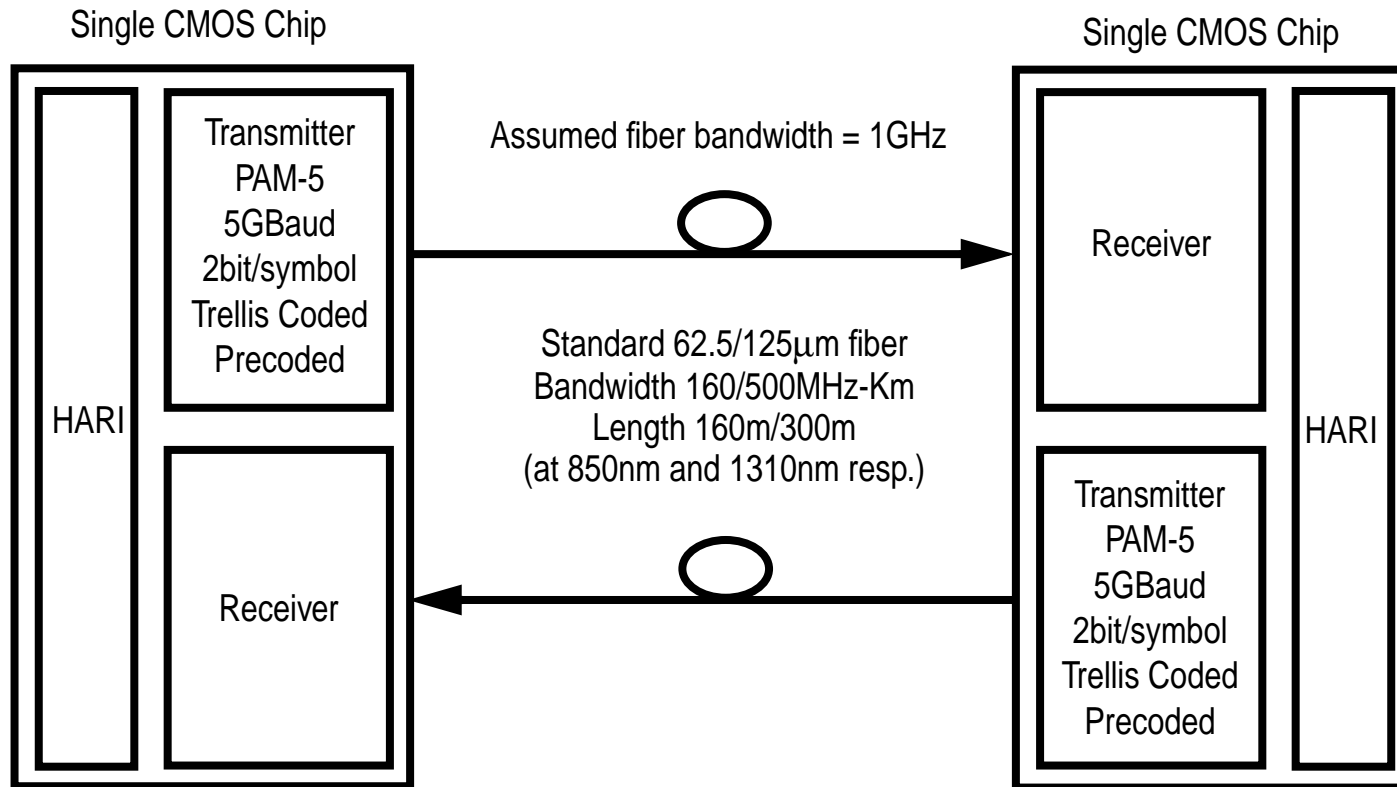

Signaling at Faster than Nyquist Rate

- **Multimode fibers have limited bandwidth (~1GHz for the fibers and lengths of interest to IEEE802.3ae - also depends on the laser)**
- **Faster than Nyquist rate is required to signal at 10Gb/s on these fibers**
- **We have studied signaling at 5GBaud over multimode fibers with 1GHz bandwidth**



Signaling at Faster than Nyquist Rate

- The Nyquist theorem establishes that the bandwidth needed to transmit data at a rate $f_B=1/T$ **without intersymbol interference** must be larger than or equal to $1/2T$
- However many communication systems signal at rates faster than $1/2T$, using special techniques to control intersymbol interference
- An example are receivers using **Decision Feedback Equalization (DFE)**
- DFE has been used for several decades in narrowband communications systems such as voiceband modems
- More recently, it has been used in **100Base-TX** and **1000Base-T** Ethernet Transceivers



Signaling at Faster than Nyquist Rate

- **Decision Feedback Equalization is almost ideally suited to the problem of equalizing multimode fibers**
- **In our simulations we signal at 2.5 times the Nyquist rate (data rate 10Gb/s, baud rate $f_B=5\text{GHz}$, bandwidth $\text{BW}=1\text{GHz}$)**
- **Our bandwidth assumption is consistent with 500m of 160/500MHz-Km fiber at 1310nm, or 160m of the same fiber at 850nm**



Conceptual Receiver Model

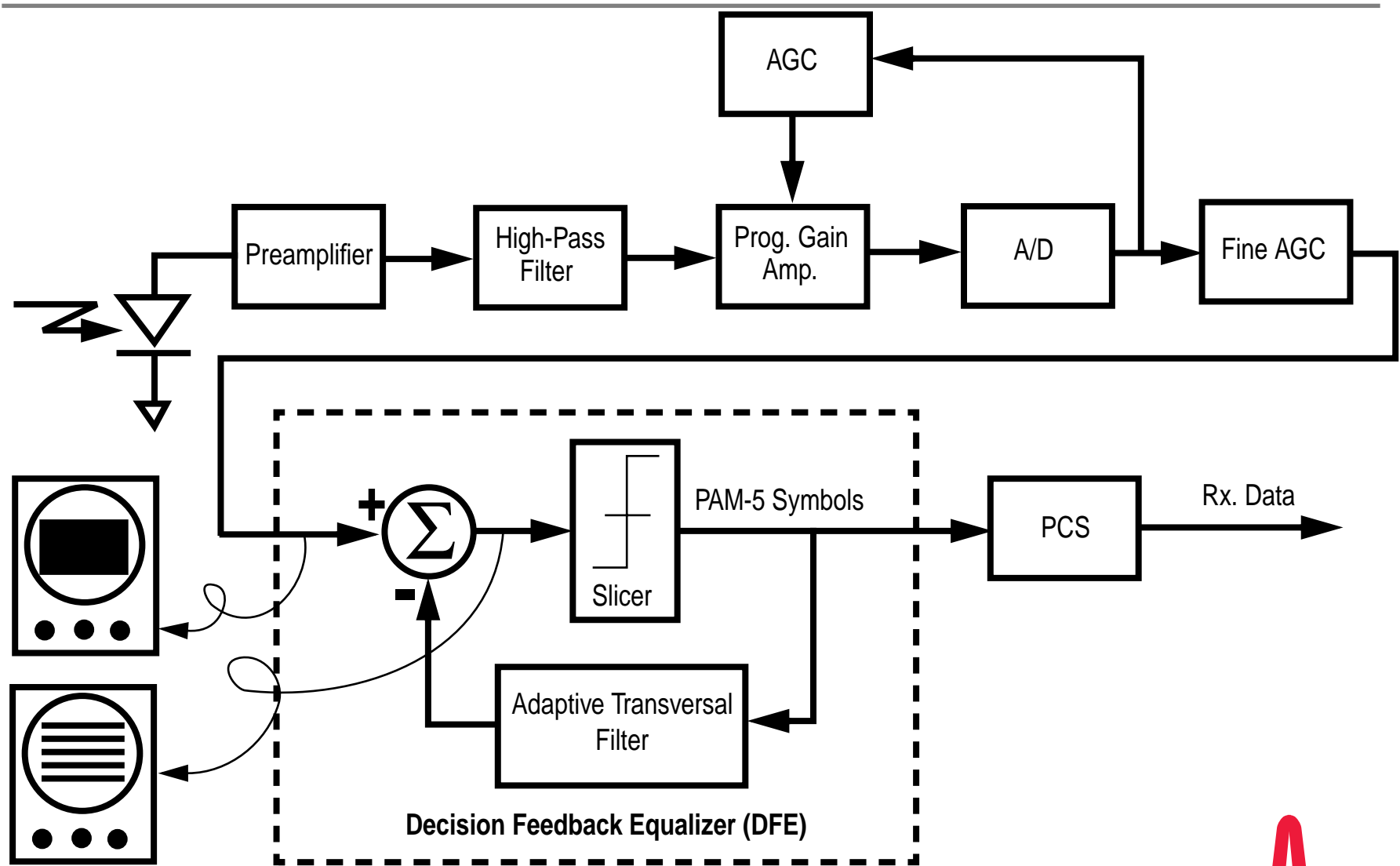

NOTE: This is a conceptual system-level diagram. More on implementation later



From Conceptual Block Diagram to Complete System Architecture

- **Move the DFE to the transmitter**
 - Transmitter equalization is known as Tomlinson-Harashima precoding
 - Precoding simplifies the use of trellis codes
 - Precoders are easier to parallelize than DFEs
- **Incorporate trellis-coded modulation**
 - We propose a 4-dimensional, 8-state, 4-way interleaved Ungerboeck code
 - Provides coding gain of about 6dB over the uncoded PAM-5 system
- **Add a forward equalizer to the receiver**
 - The forward equalizer provides phase equalization (all-pass response), necessary to equalize some non-minimum-phase fiber responses
- **Use parallel processing implementation of transmitter, receiver, and data converters**
 - Achieve 5GHz effective sampling rate with 312.5MHz actual clock rate



Tomlinson-Harashima Precoding (THP)

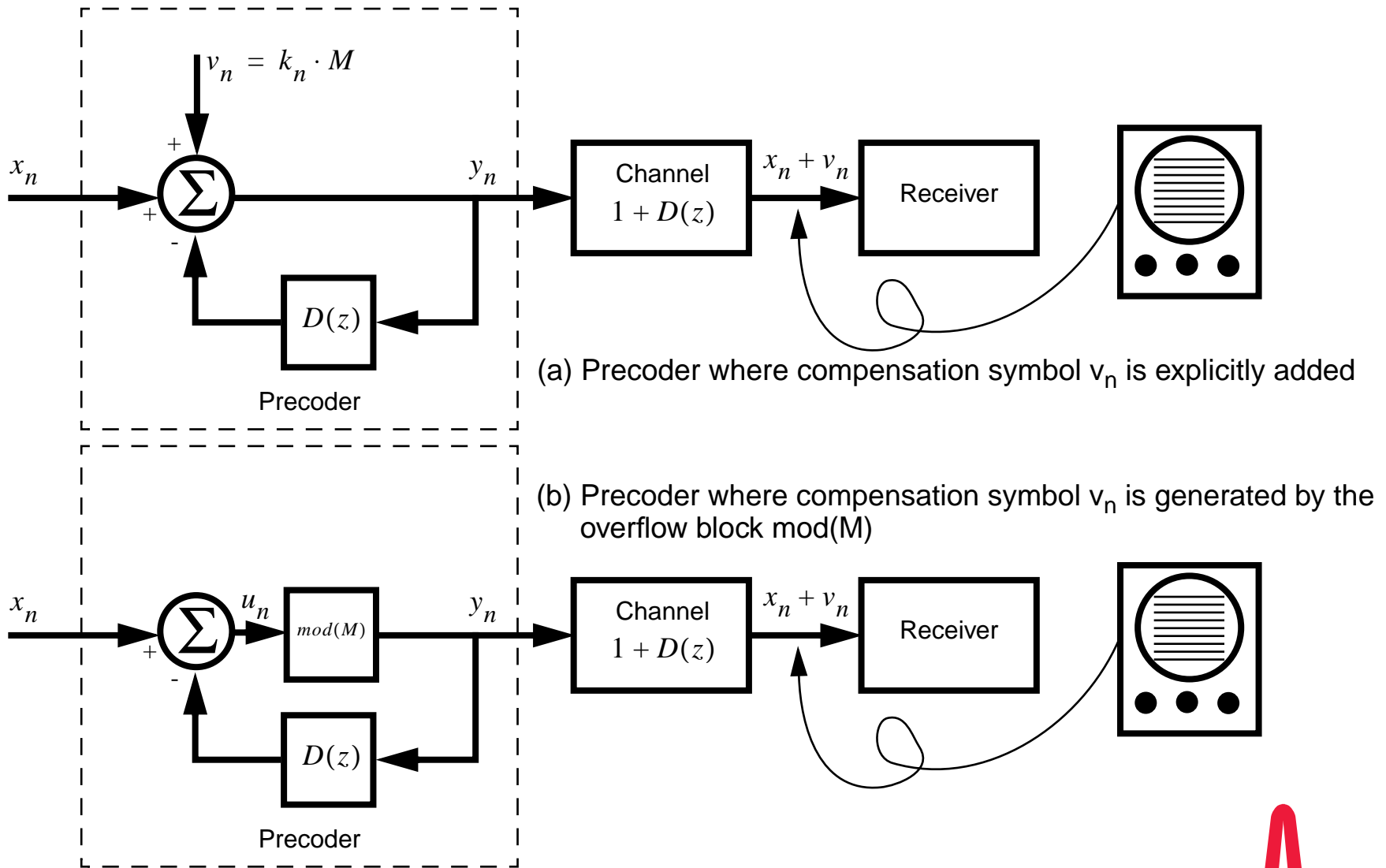

Tomlinson-Harashima Precoding (THP)

- The precoder is essentially a filter with a response equal to the inverse of the channel
- For example, if the channel response has a z-transform $1 + D(z)$, the precoder must have a response $\frac{1}{1 + D(z)}$, which can be implemented as shown in the previous viewgraph
- However the inverse filter could introduce high gain at some frequencies (where the channel has high attenuation). This would result in high peak values and high power at the transmitter output
- To prevent this from happening, a sequence $v_n = k_n \cdot M$ is added to the transmitted data sequence x_n
- For a PAM-5 alphabet ($x_n \in \{-2, -1, 0, 1, 2\}$), $M = 5$ and k_n is an arbitrary integer, such that $x_n + v_n$ belongs to the **expanded alphabet** $\{\dots, -7, -6, -5, -4, -3, -2, -1, 0, 1, 2, 3, 4, 5, 6, 7, \dots\}$
- The specific choice of k_n is made on a symbol by symbol basis with the objective of minimizing the transmitted power



Tomlinson-Harashima Precoding

- In traditional Tomlinson-Harashima precoding, a wrap-around (or overflow) operation is used to automatically generate v_n . This operation is denoted with the symbol $\text{mod}(M)$ in the diagram of page 6
- If its input is $u_n \geq M/2$, the $\text{mod}(M)$ block forces y_n to the interval $[-M/2, M/2)$ by adding $k_n \cdot M$ with $k_n < 0$. Similarly, if $u_n < M/2$ forces y_n to fall in the same interval by adding $k_n \cdot M$ with $k_n > 0$. Notice that this is precisely the behavior of the two's complement representation of a number u_n when it overflows a register whose word length allows representing numbers in the interval $[-M/2, M/2)$
- The received signal is $x_n + v_n$. A perfectly open eye pattern is achieved at the receiver input, however the number of levels is larger than in the original alphabet (in a PAM-5 system, we get more than 5 levels at the input of the receiver)
- The slicer determines x_n by finding the value of k_n that makes $x_n + v_n - k_n \cdot M$ fall inside the original PAM-5 alphabet $\{-2, -1, 0, 1, 2\}$



Dynamics Limited Precoding (DLP)

- In THP, k_n can take arbitrary integer values in order to strictly enforce the condition $-M/2 \leq y_n < M/2$
- This could result in large values of $x_n + v_n$, which is the signal at the input of the receiver
- To reduce the dynamic range of the A/D converters, it is desirable to constrain $x_n + v_n$. For example, in a PAM-5 system one might choose $x_n + v_n \in \{-4, -3, -2, -1, 0, 1, 2, 3, 4\}$
- This results in a slight increase of the transmit power, but the benefit is a reduction of the resolution of the A/D
- The implementation of DLP is straightforward

Reference [3]



Advantages of Precoding over Receiver Equalization

- **The precoder lends itself better to a parallel implementation than the DFE**
- **When using Trellis Coded Modulation, precoding allows the trellis decoder to be substantially simplified, since the latter does not have to deal with intersymbol interference**
- **Precoding avoids error propagation, which is a (minor) problem of the DFE**
- **It is a well established result in Communication Theory that the combination of precoding with coded modulation approaches the Shannon bound for channel capacity when good modulation codes are used. Therefore this is an asymptotically optimal architecture (ref.[4])**



Trellis Coding

- We propose a 4-dimensional, 8-state, 4-way interleaved Ungerboeck code
- The constituent 4-dimensional Ungerboeck code is the same used in 1000Base-T
- The 4 dimensions consist of 4 consecutive samples of the signal
- Because of the 4 way interleaving, the code operates in blocks of 16 samples with a block rate of $5\text{GHz}/16=312.5\text{MHz}$
- This provides an intrinsic parallelism (by a factor 16) in both the coder and the decoder, which run at a clock rate of 312.5MHz

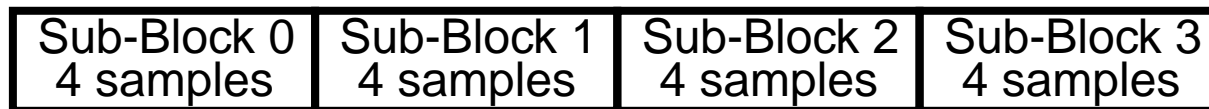

Block Size = 16 samples
Block Rate = 312.5MHz



Constituent Trellis Encoder for Each One of the Four Interleaves of the Code

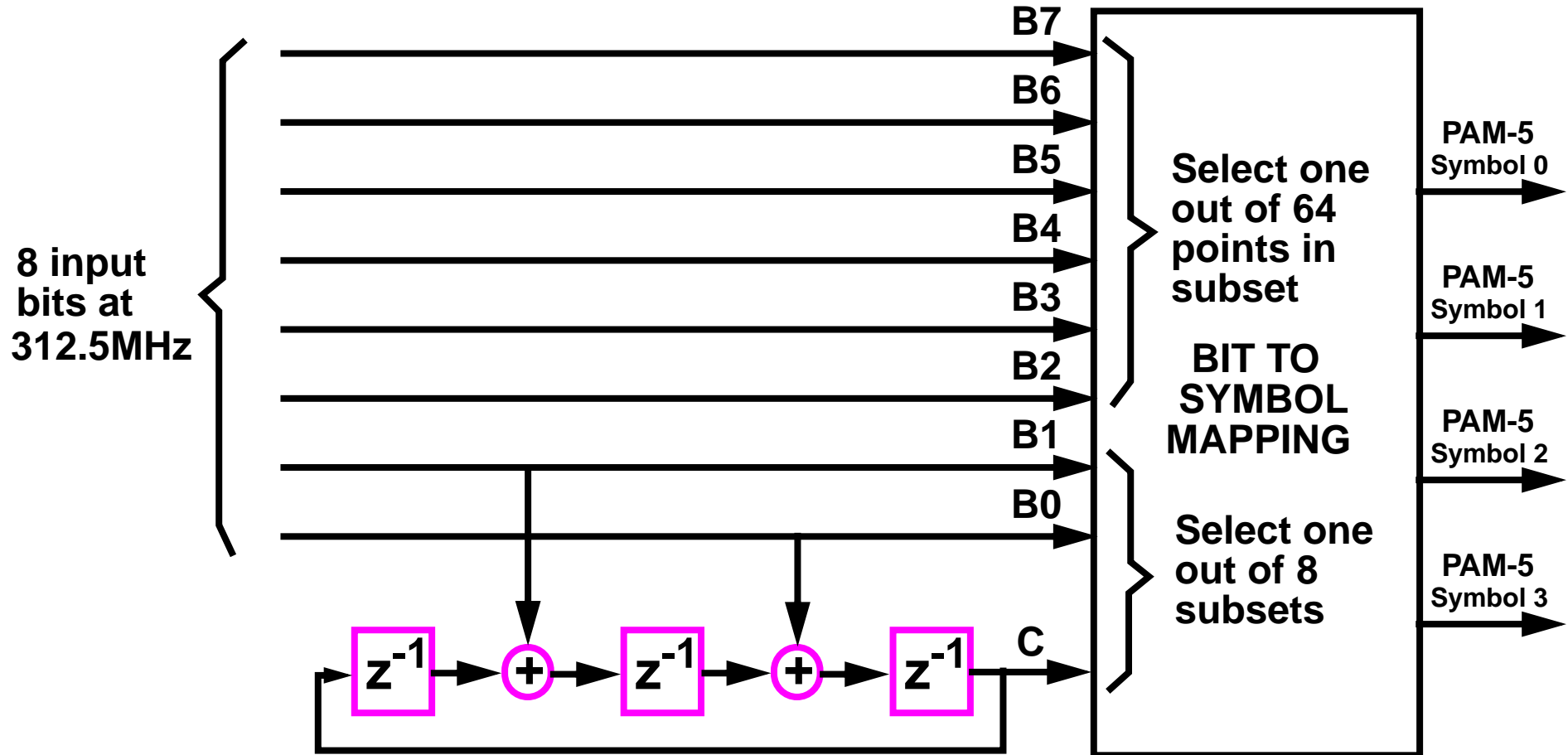

Transmitter Block Diagram

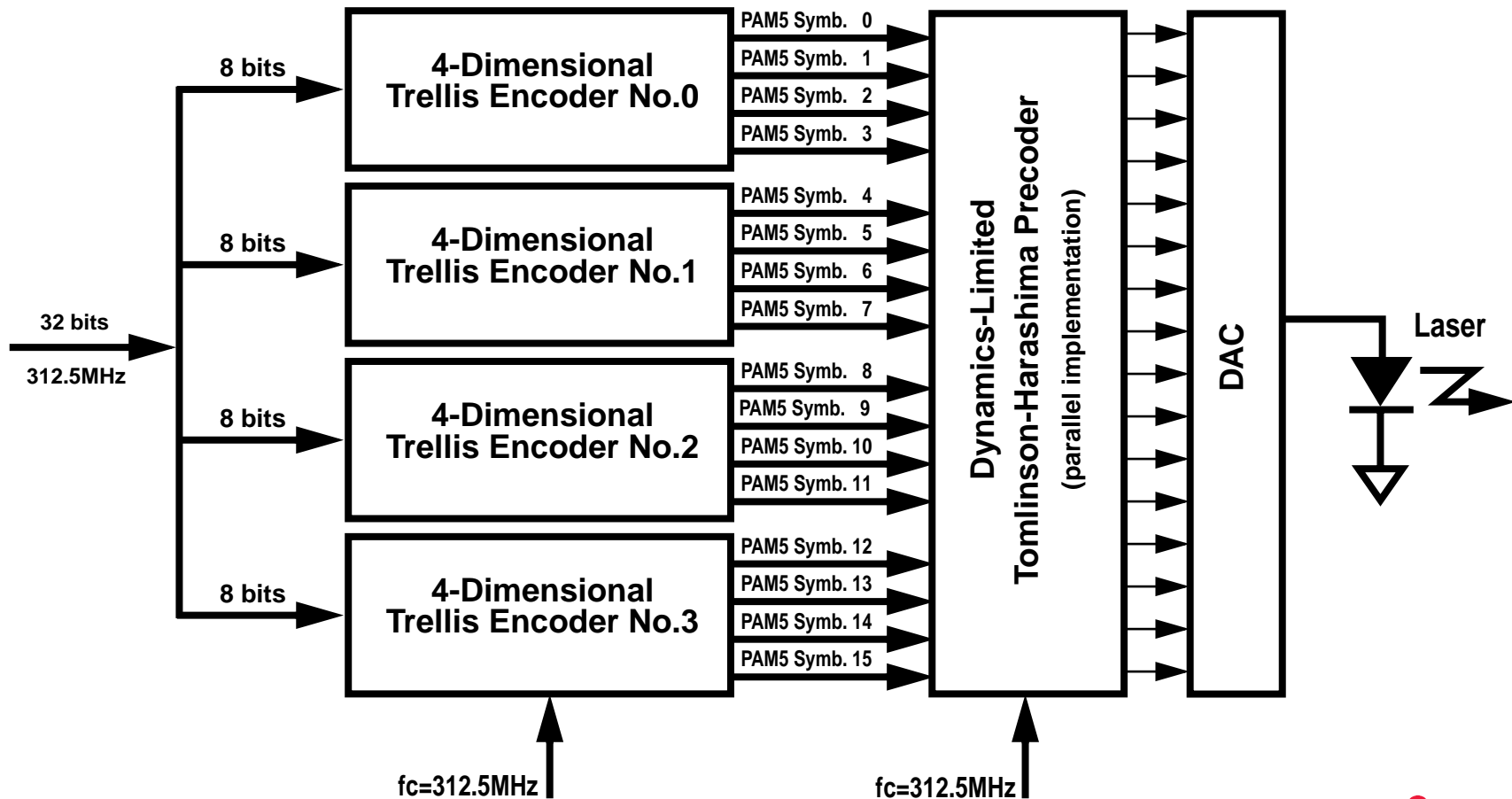

Receiver Block Diagram

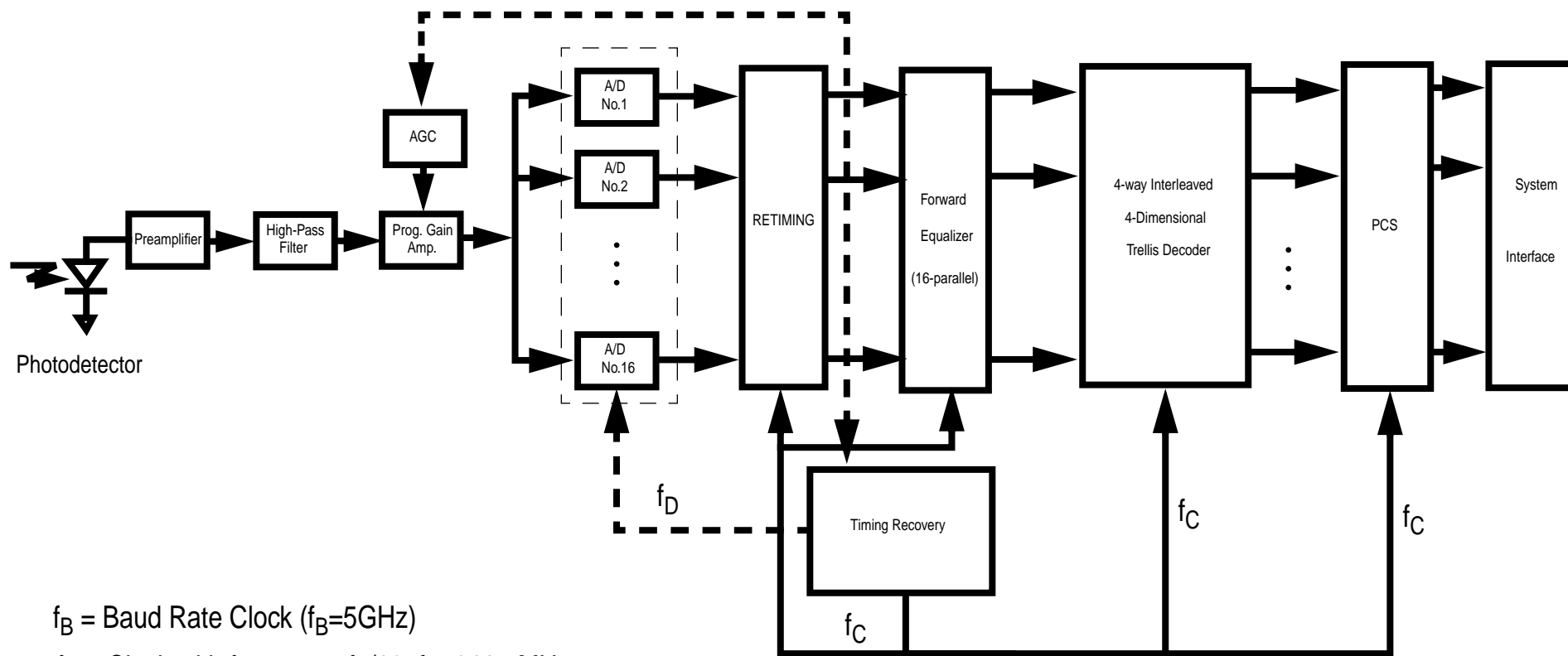

f_B = Baud Rate Clock ($f_B=5\text{GHz}$)

f_C = Clock with frequency $f_B/16$, $f_C=312.5\text{MHz}$

f_D = 16-phase version of f_C



Precoder Initialization

- During startup a buffer captures blocks of N consecutive baud-rate samples (for example N=1024) from the A/D converter at 312.5MHz clock rate
- The Forward Equalizer and an auxiliary DFE in the receiver are trained at a reduced clock rate, for example $f_{SLOW}=100\text{MHz}$ using samples from the buffer. While the buffer is being emptied, signal samples from the A/D are discarded. Once the equalizer is trained, the DFE coefficients are sent to the transmitter on the other end of the link
- Data can be transmitted and received during these blocks, except for a transient period at the beginning of the block
- Since this procedure is executed at both ends of the link, this establishes a full-duplex ***“startup channel”***
- Data rate of the ***“startup channel”*** is approximately 200Mb/s (for $f_{SLOW}=100\text{MHz}$)
- The ***“startup channel”*** can be used during startup to send DFE coefficients from the receiver to the transmitter and enable programming of the precoder



Laser Model

- The laser is modeled using the rate equations (ref.[6]). These are a system of coupled nonlinear differential equations. They provide accurate description of nonlinear and transient behavior of the laser
- We use the exact equations (not approximations) and we solve them numerically using a 4th order Runge-Kutta algorithm
- The parameters used are the same as in ref.[6], except that the bias current is increased to $3 I_{\text{threshold}}$
- We modulate the laser with a precoded pseudo-random sequence of symbols from a PAM-5 alphabet
- We use a 6dB extinction ratio



Precoded PAM-5 5 GBaud Modulated Laser Output

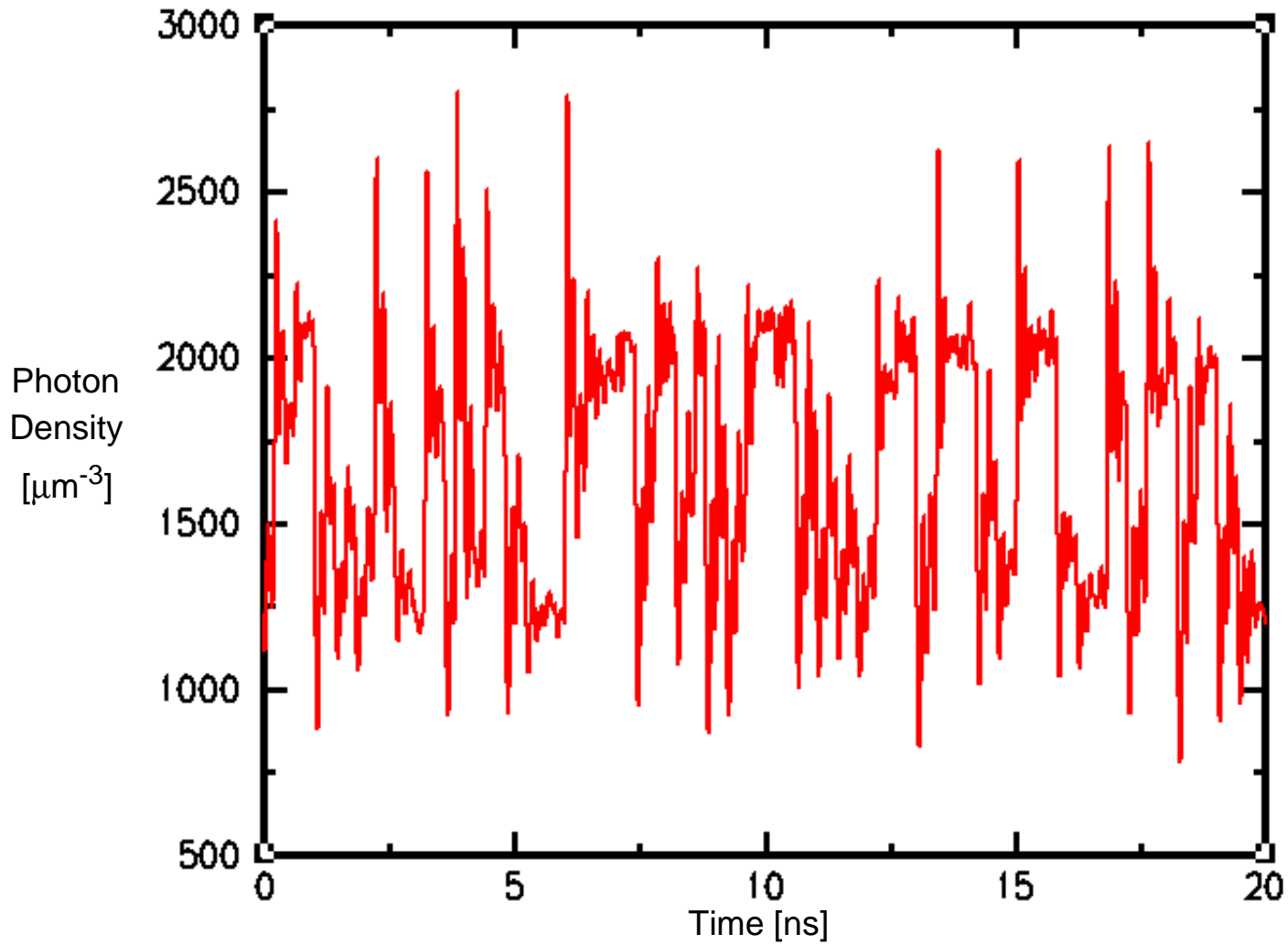

Zoom of Modulated Laser Output

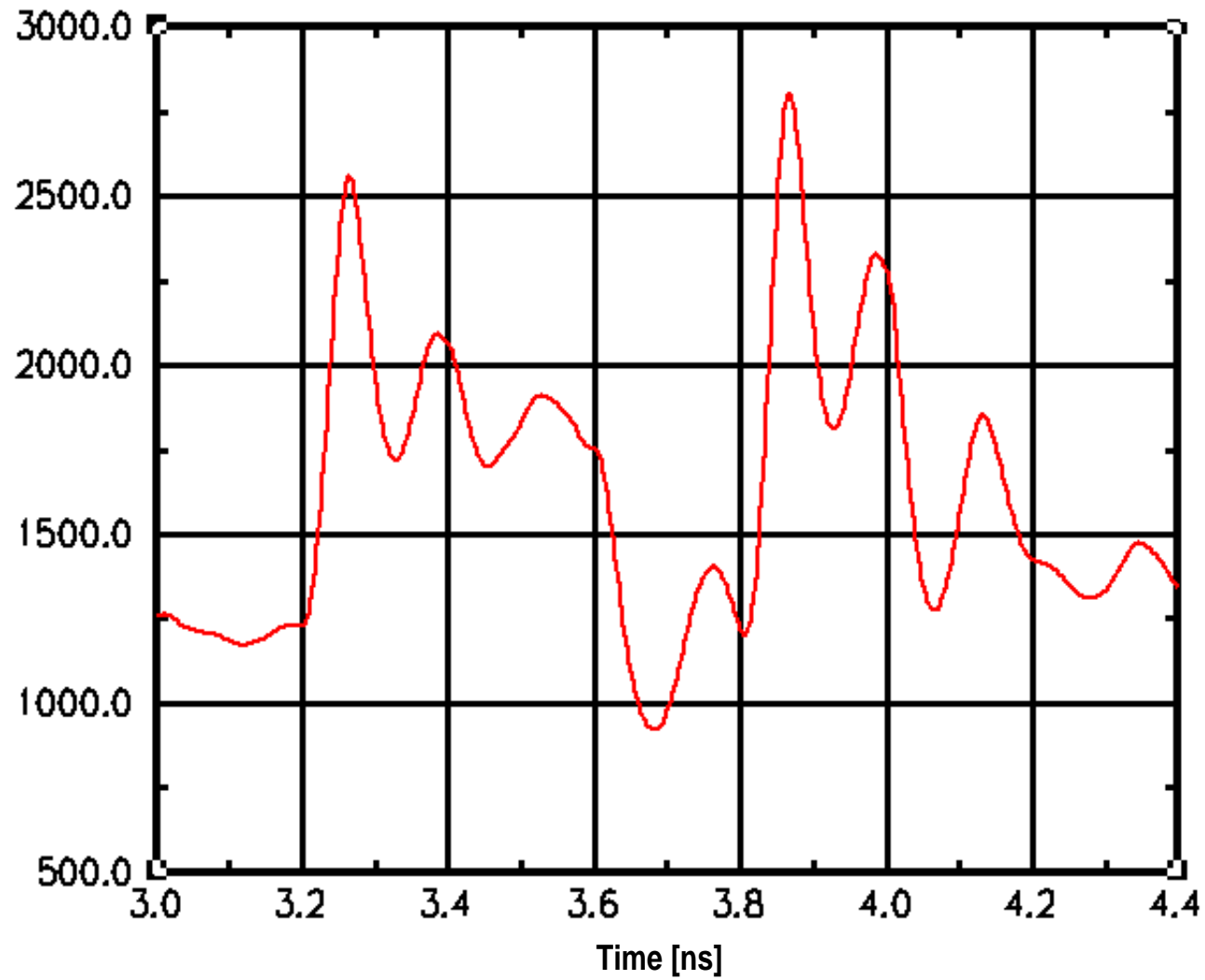

Fiber Impulse Responses Used in Simulations

- The impulse responses we use in our simulations were obtained by fitting Gaussian functions to the measured responses provided by ref.[7]
- We also use the Gaussian response described in our Dallas presentation last January
- The impulse responses from ref.[7] correspond to 2.2Km of 65/125 μ m fiber. We scaled them to a fiber length of 500m
- The analytic expressions for the fitted responses are:

$$y(t) = \sum_{k=0}^3 A_k \cdot e^{-(t-t_k)^2/2 \cdot \sigma_k^2 \cdot T^2}$$

- where parameters A_k, t_k, σ_k are given by the tables of pages 25 and 26



Fiber Impulse Responses Used in Simulations

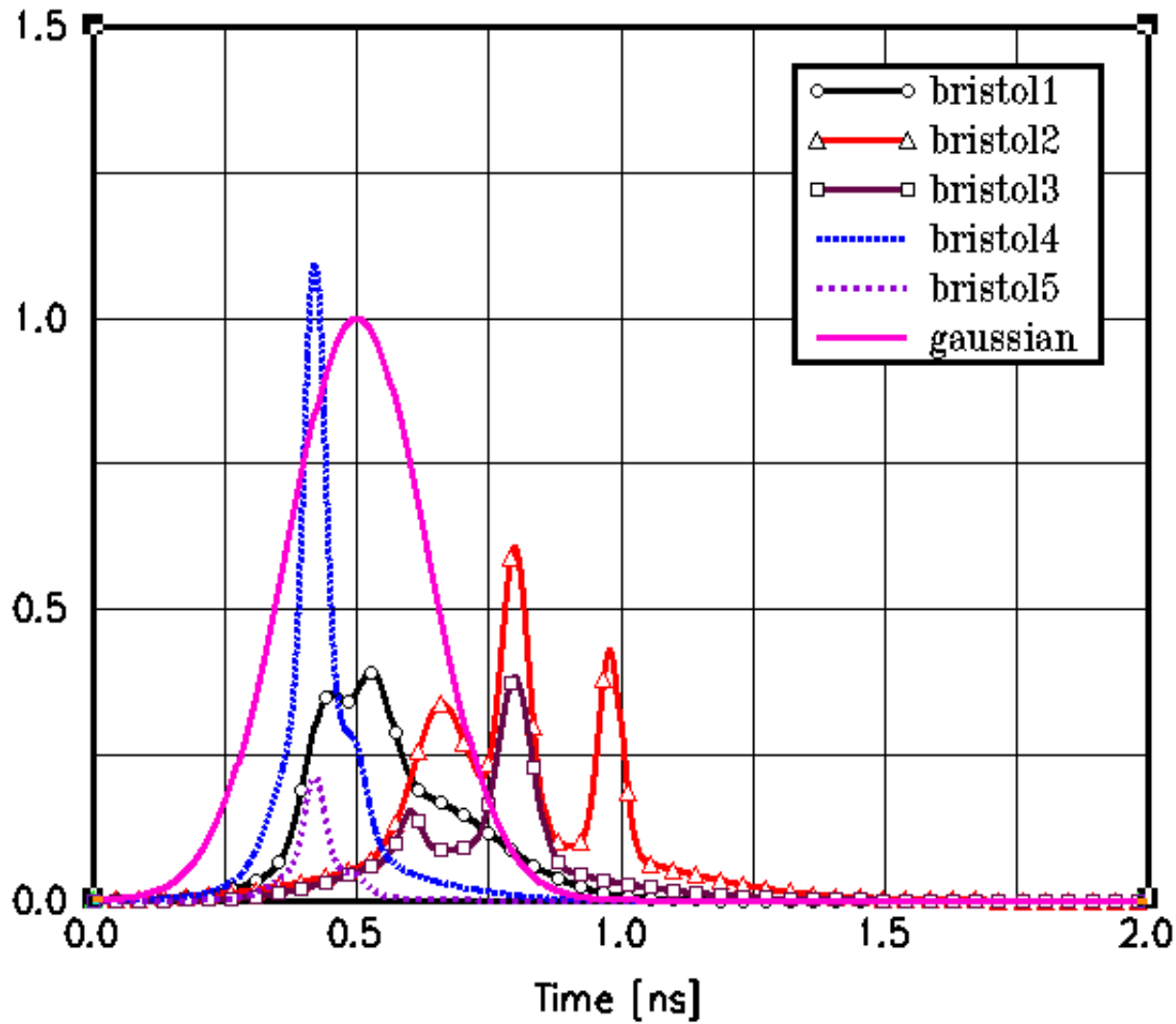

Parameters of Impulse Responses

A_k	k=0	k=1	k=2	k=3
Gaussian	1.0	0.0	0.0	0.0
Bristol1	0.2325	0.2190	0.0	0.18
Bristol2	0.25	0.5	0.35	0.1
Bristol3	0.075	0.31	0.025	0.075
Bristol4	0.75	0.08	0.3	0.05
Bristol5	0.15	0.016	0.06	0.001

t_k/T	k=0	k=1	k=2	k=3
Gaussian	1.0	1.0	1.0	1.0
Bristol1	0.7	1.15	2.4	1.5
Bristol2	0.8	1.5	2.4	1.5
Bristol3	1.5	2.5	3.0	1.8
Bristol4	0.6	1.0	0.6	1.0
Bristol5	0.6	1.0	0.6	1.0



Parameters of Impulse Responses

σ_k	k=0	k=1	k=2	k=3
Gaussian	0.6625	0.6625	0.6625	0.6625
Bristol1	0.1789	0.1789	0.0596	0.7950
Bristol2	0.2650	0.1325	0.1060	1.3250
Bristol3	0.0994	0.1590	0.9937	0.7950
Bristol4	0.0894	0.0994	0.3180	0.7950
Bristol5	0.0894	0.0994	0.3180	0.7950



Fiber Impulse Responses After Front-End Filtering and Amplification

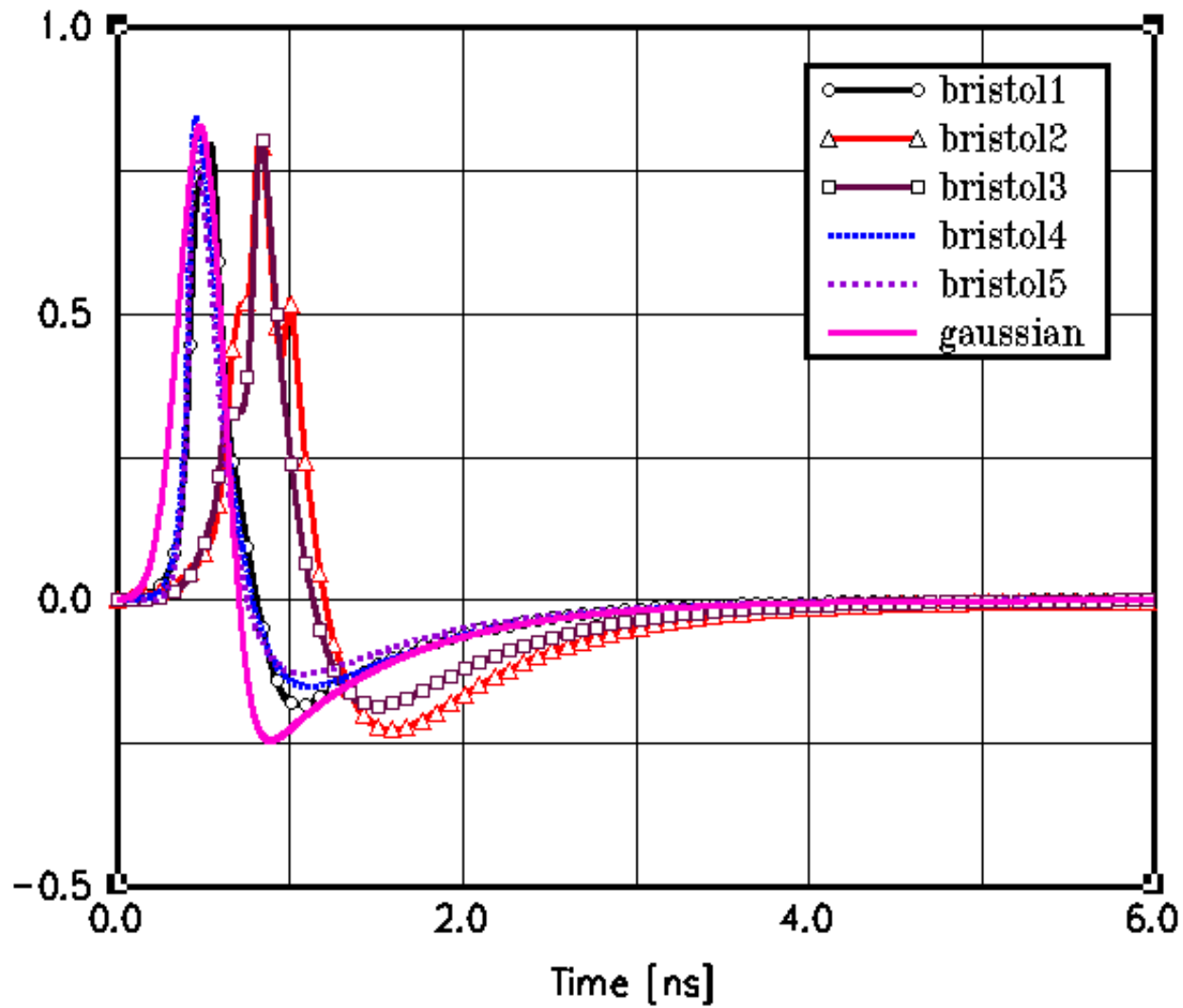

Precoded PAM-5 5 GBaud Signal at the Input of the Receiver

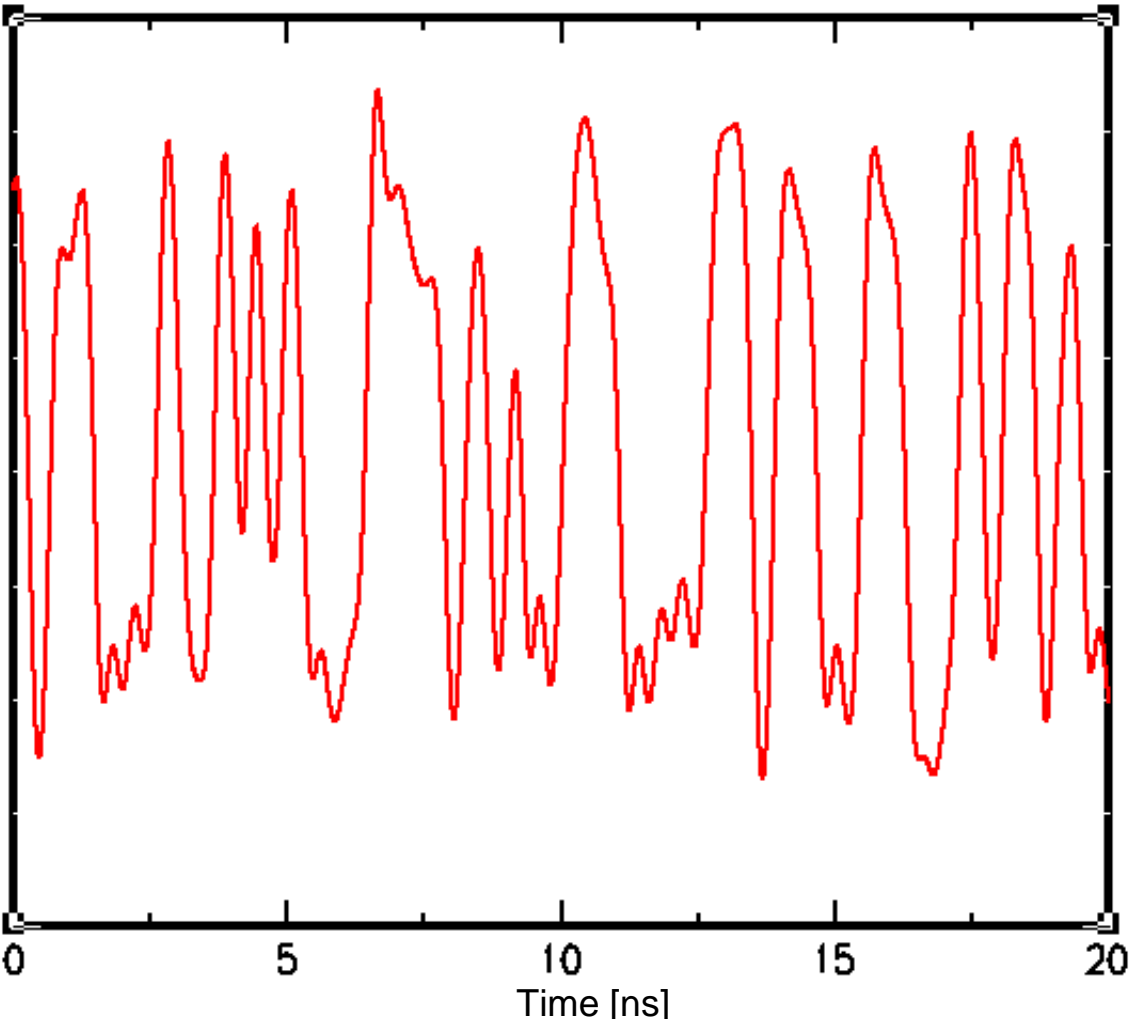

Eye Pattern for Gaussian Response (Noise-Free Case)

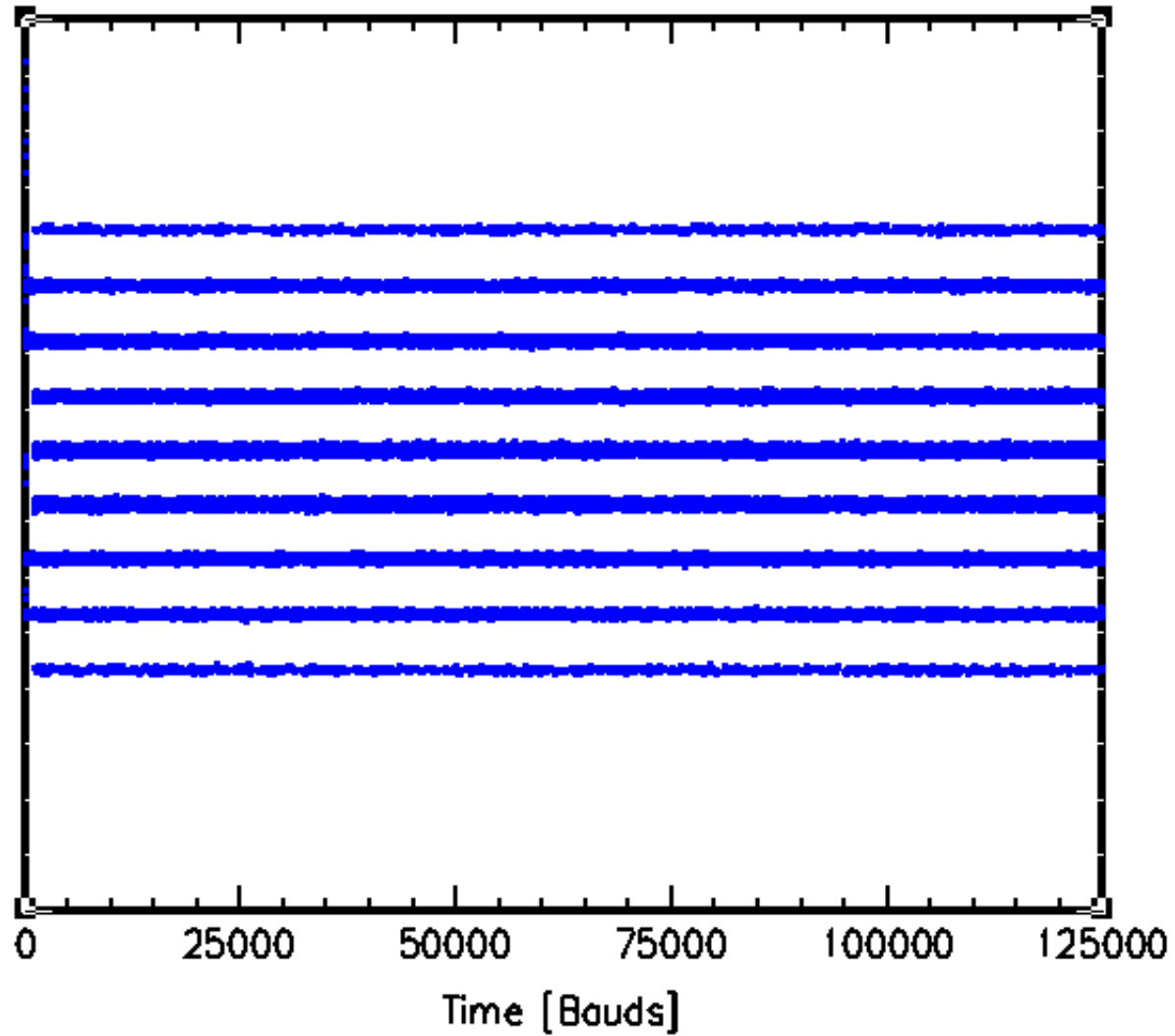

Eye Pattern for Gaussian Response ($RIN=-130\text{dB/Hz}$)

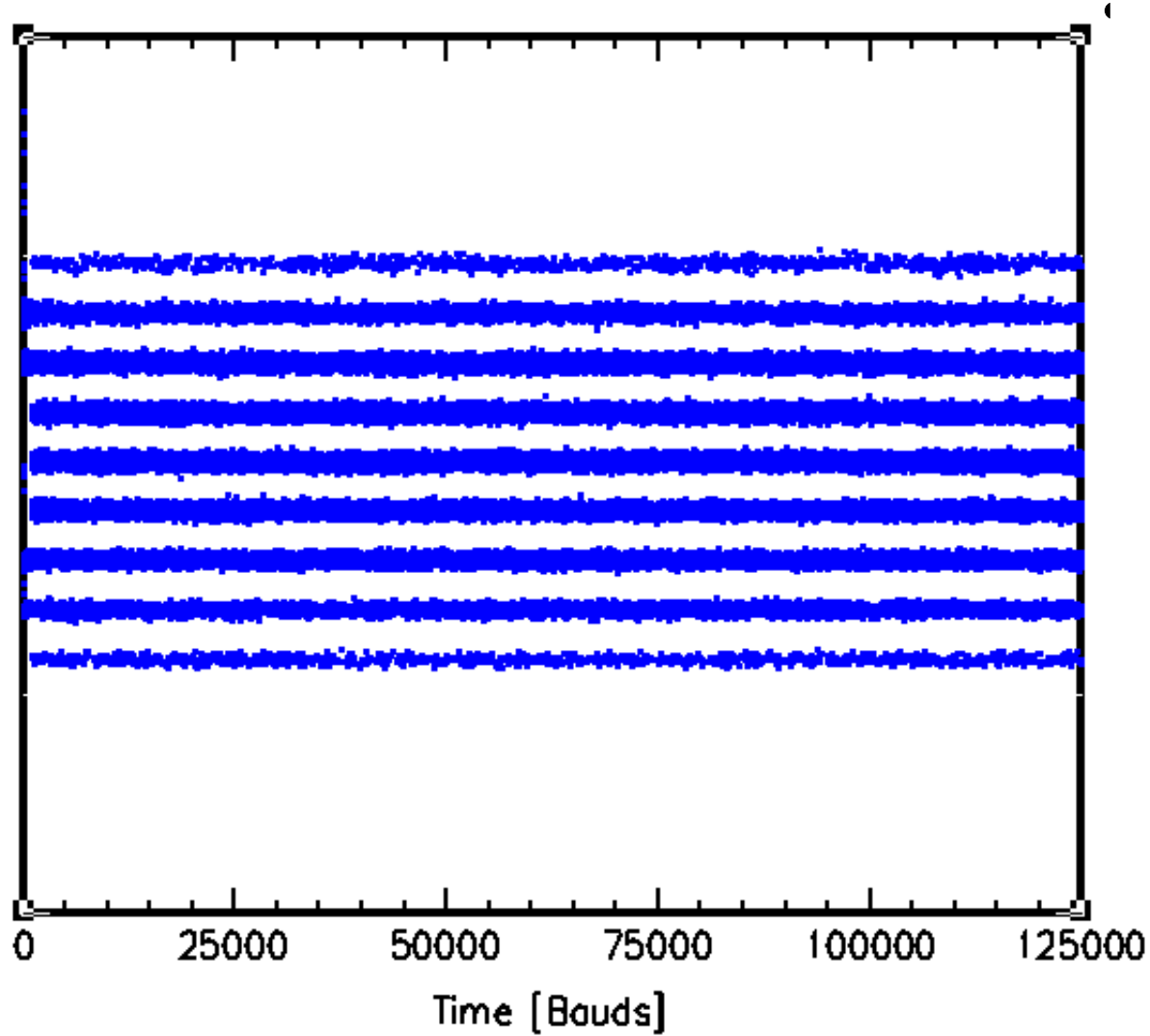

Eye Pattern for Bristol1 Response (Noise-Free Case)

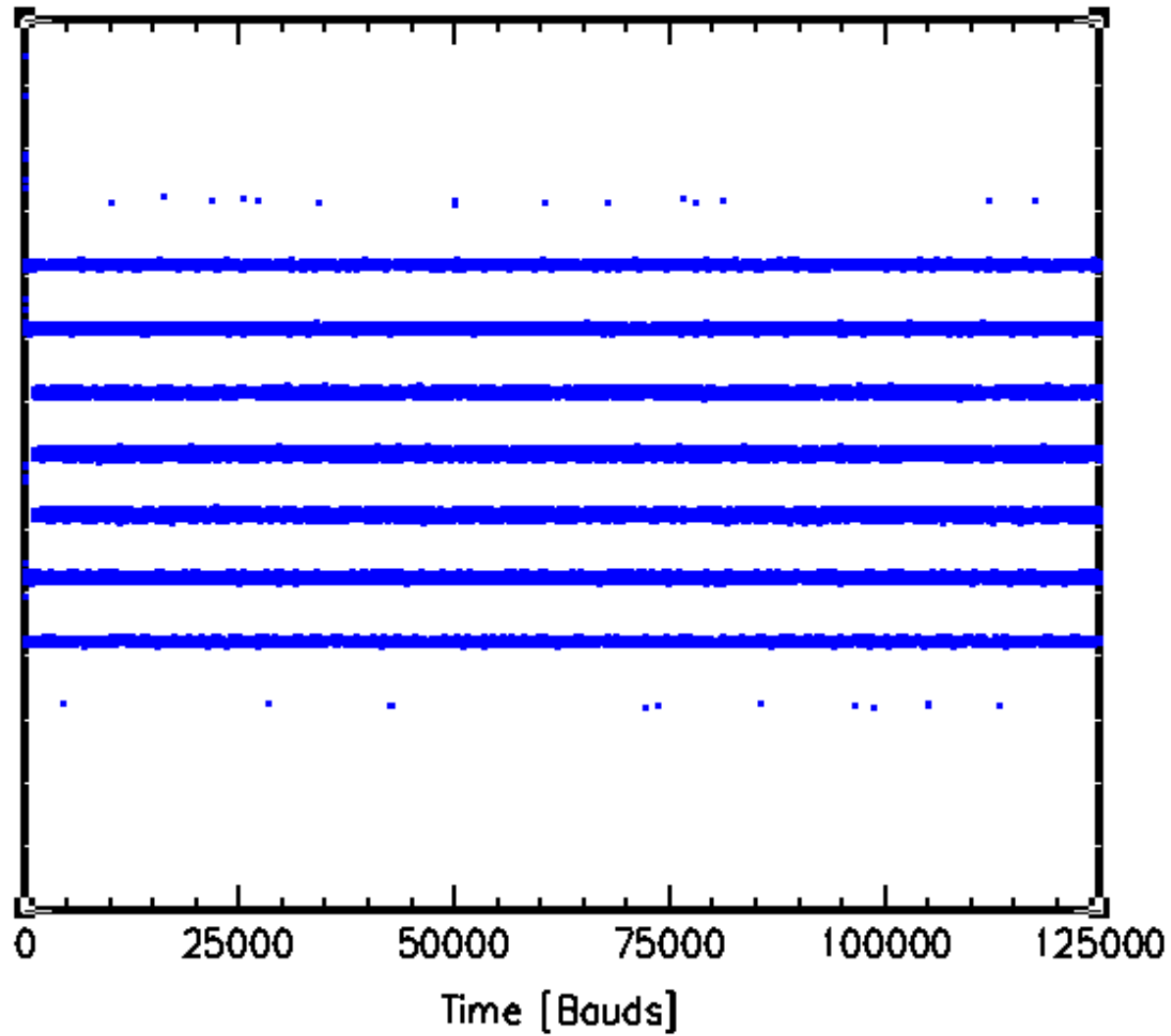

Eye Pattern for Bristol1 Response (RIN=-130dB/Hz)

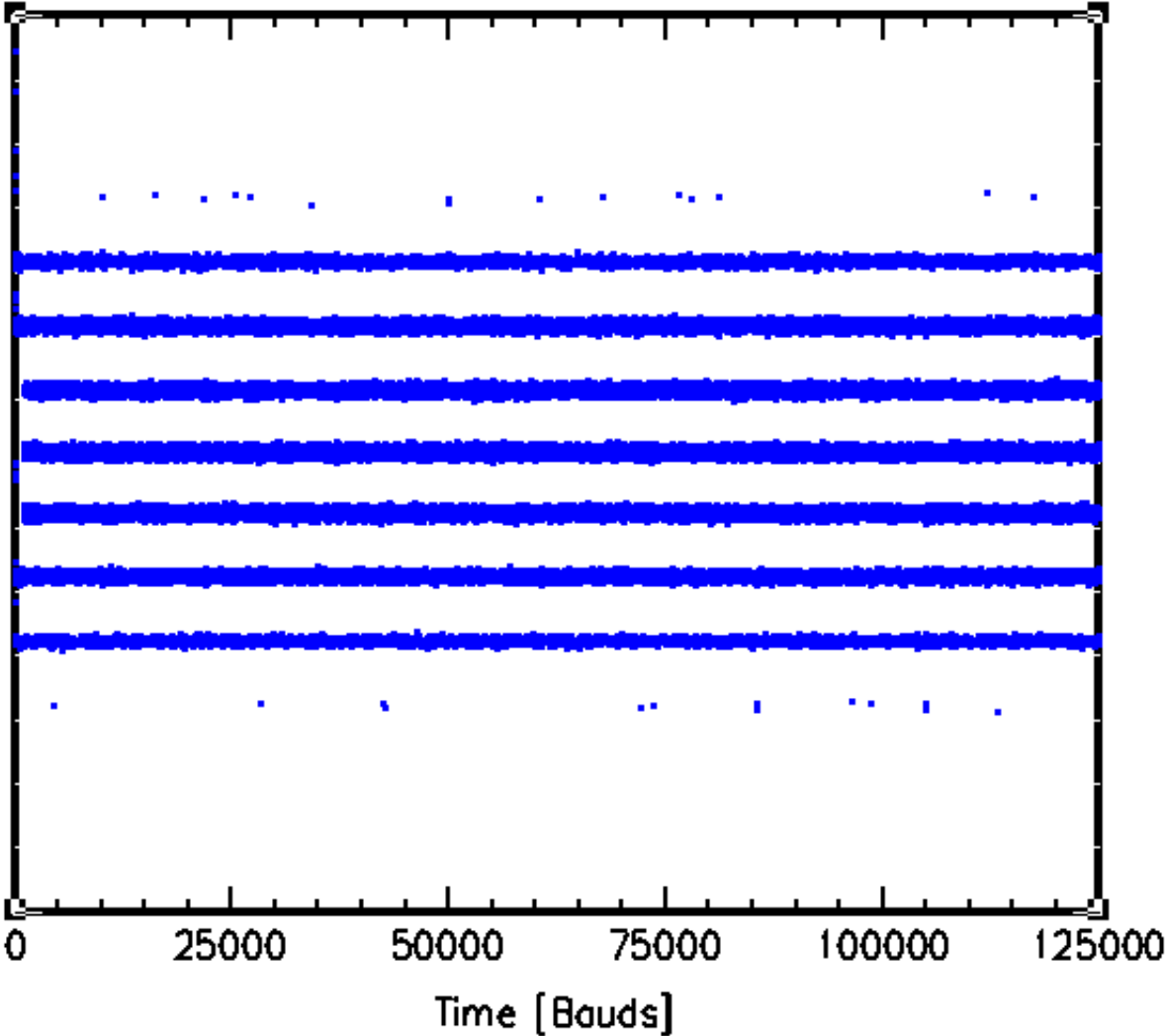

Eye Pattern for Bristol2 Response ($RIN=-130\text{dB/Hz}$)

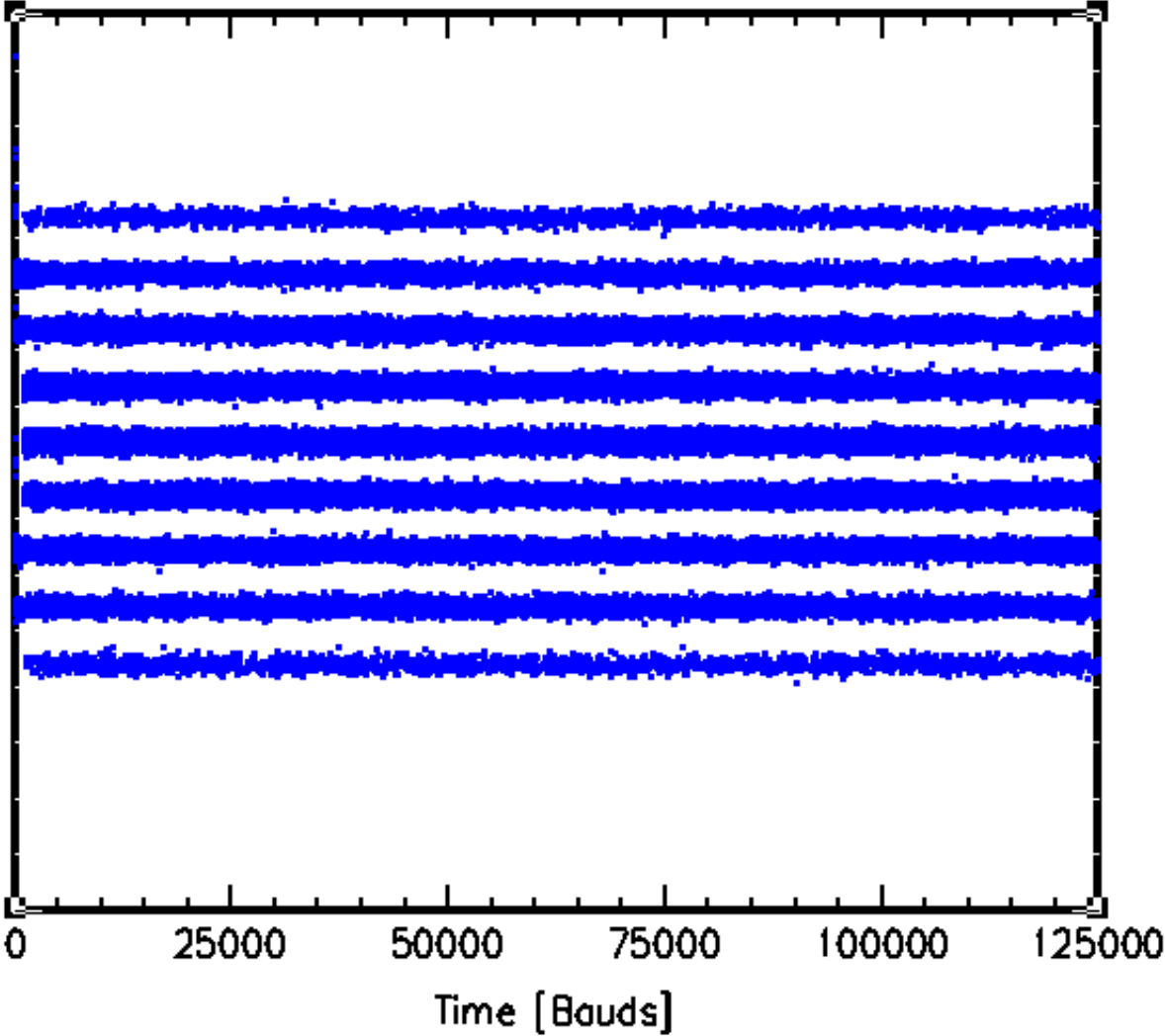

Eye Pattern for Bristol3 Response ($RIN=-130\text{dB/Hz}$)

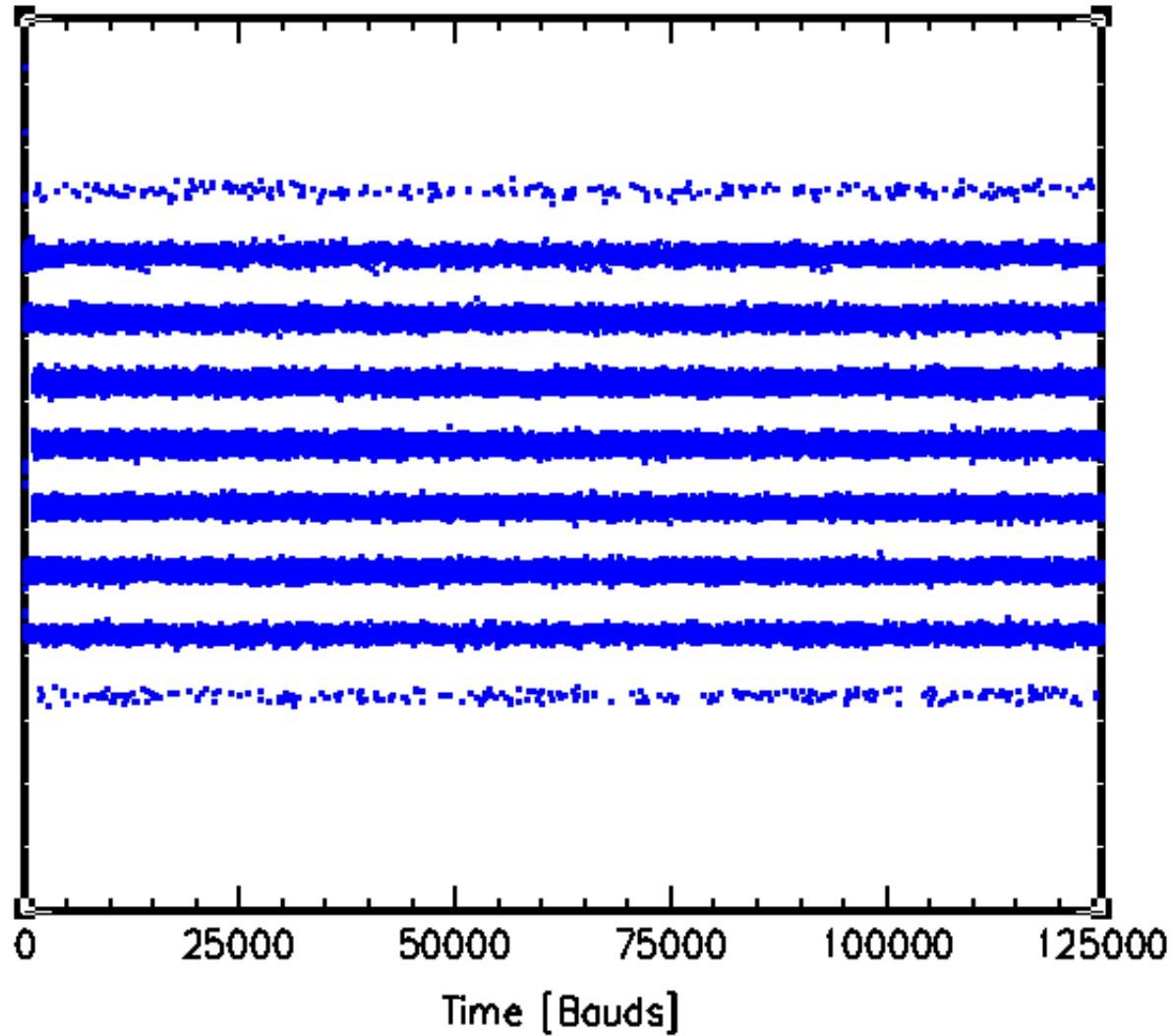

Eye Pattern for Bristol4 Response (RIN=-130dB/Hz)

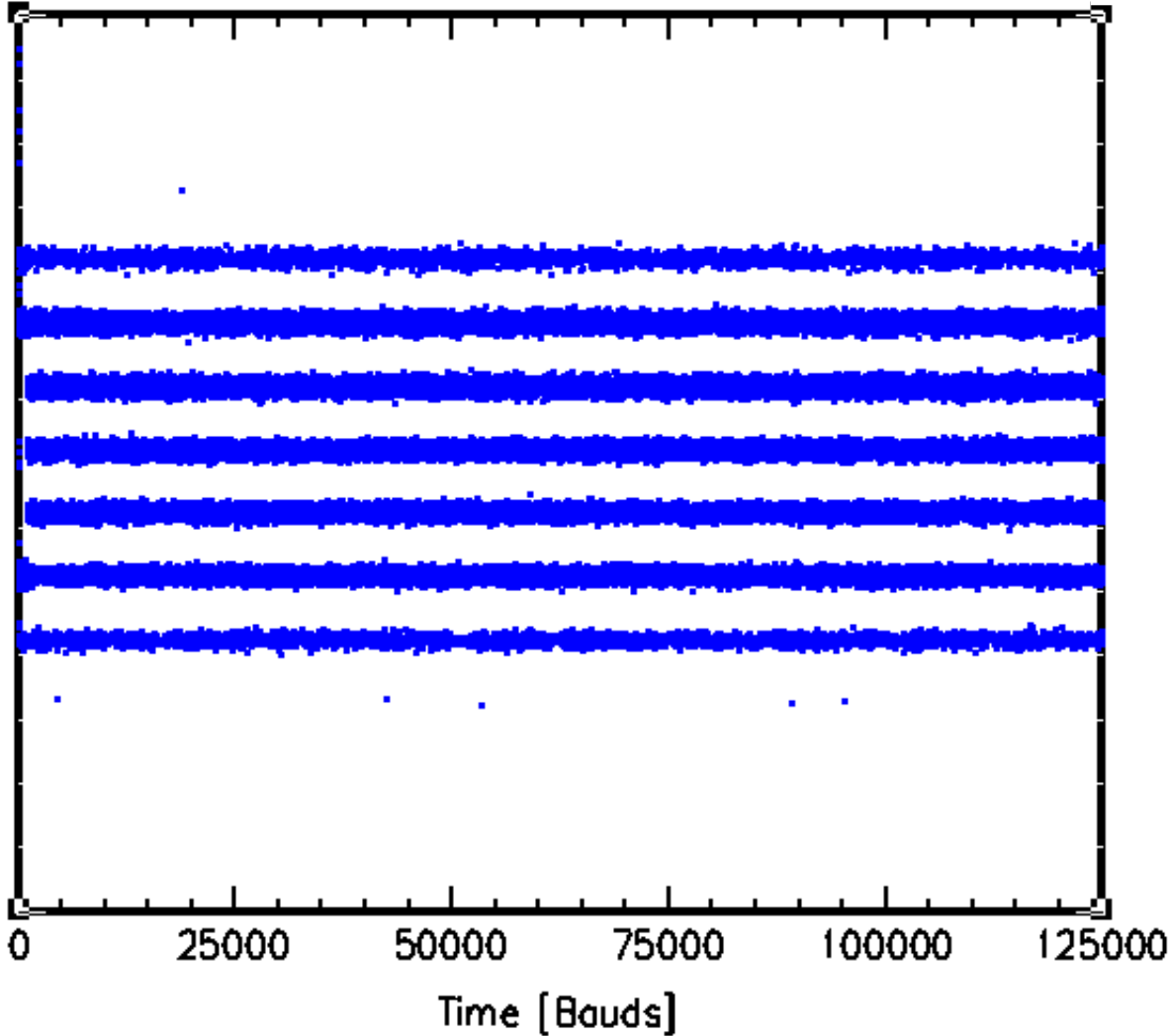

Eye Pattern for Bristol5 Response ($RIN=-130\text{dB/Hz}$)

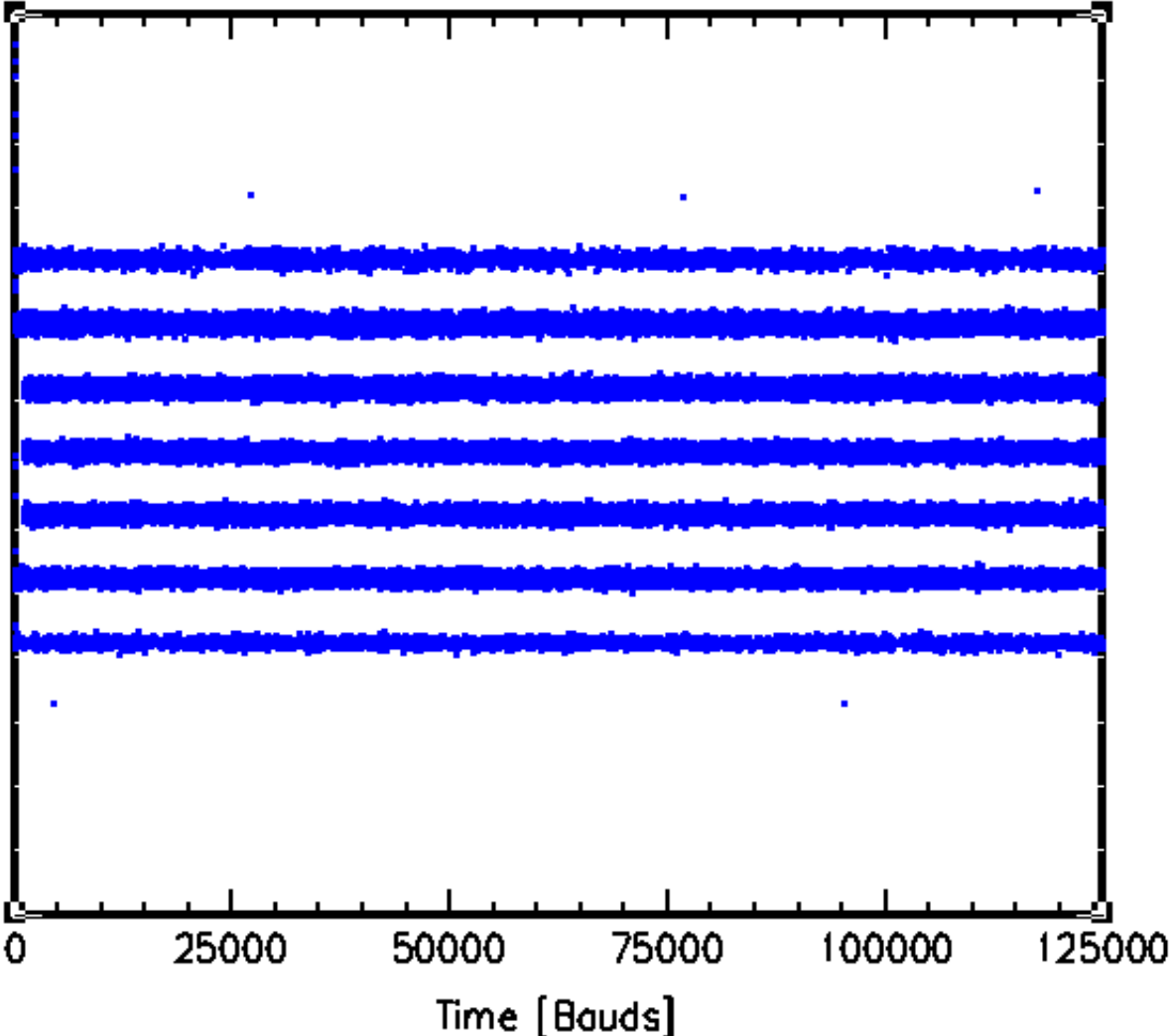

Conclusions

- We have proposed an asymptotically optimal architecture for a 10Gb/s PMD using PAM-5 Trellis Coded Modulation
- The proposed architecture has been simulated using a realistic laser model based on the rate equations, and measured impulse responses for standard 160/500 MHz-Km multimode fiber from ref.[7]
- Simulated performance supports error-free transmission over more than 300m of standard 160/500 MHz-Km multimode fiber at 1300nm.
- The proposed architecture lends itself well to a fully parallel DSP implementation using a clock rate of 312.5MHz
- Parallel DSP implementation and analog circuit design are covered in the companion presentations by K.Parhi and P.Vorenkamp



References

- [1] H.Harashima and H.Miyakawa, "A Method of Code Conversion for a Digital Communication Channel with Intersymbol Interference," *Transactions Institute Electronic Communication Engineering (Japan)*, **52-A**, June 1969.
- [2] M.Tomlinson, "New Automatic Equalizer Employing Modulo Arithmetic," *Electronic Letters*, **7**, March 1971.
- [3] R.Fischer, W.Gerstacker, and J.Huber, "Dynamics Limited Precoding, Shaping, and Blind Equalization for Fast Digital Transmission over Twisted Pair Lines," *IEEE J. Selected Areas in Communications*, **Vol.13**, No.9, Dec.1995.
- [4] R.Price, "Nonlinearly Feedback-Equalized PAM vs. Capacity for Noisy Filter Channels," *Proc. 1972 IEEE International Conf. Communications*, June 1972.
- [5] Lee and Messerschmitt, "Digital Communication", Second Edition, Kluwer 1994.
- [6] D.Marcuse and T.P.Lee, "On Approximate Analytical Solutions of the Rate Equations for Studying Transient Spectra of Injection Lasers," *IEEE J. Quantum Electronics*, Sept.1983.
- [7] L.Raddatz, I.H.White, D.G.Cunningham, and M.C.Nowell, "An Experimental and Theoretical Study of the Offset Launch Technique for the Enhancement of the Bandwidth of Multimode Fiber Links," *IEEE J. Lightwave Tech.*, March 1998.

