

# XGP



## MSA (Multi-Source Agreement) Group

### Overview and Status Report

*Chris Simoneaux / Jack Jewell*  
*Picolight, Inc - Boulder, CO*  
303-530-3189  
csimoneaux@picolight.com

*IEEE 802.3ae Interim Meeting - New Orleans*  
*September 12 - 14, 2000*

---

**XGP MSA**

# Who is the XGP MSA Group?



- Group of 14 participating transceiver companies in the process of establishing a charter with a goal to develop an MSA document for 10Gbps optical transceivers
- Many of our participants from the SFP (Small Form-factor Pluggable) MSA group
- Develop a common transceiver package footprint to support the 10Gbps communications market
- Deliver footprint and functional specs to the industry in a timely manner
- Utilize ongoing industry feedback and liaison mechanisms through strong links to marketing and standards bodies

---

**XGP MSA**

# Objectives



- Target P802.3ae requirements as well as other 10Gbps standards, such as 10Gig Fibre Channel
- Support 4-Lane electrical interface
- Pluggable electrical interface based on SFP connector design (hot pluggable desired)
- Leverage SFP mechanical design
- Support multiple fiber and electrical media connectors
- Mechanical form factor to support high density, EMI considerations, and thermal dissipation

---

**XGP MSA**

# Example Block Diagram

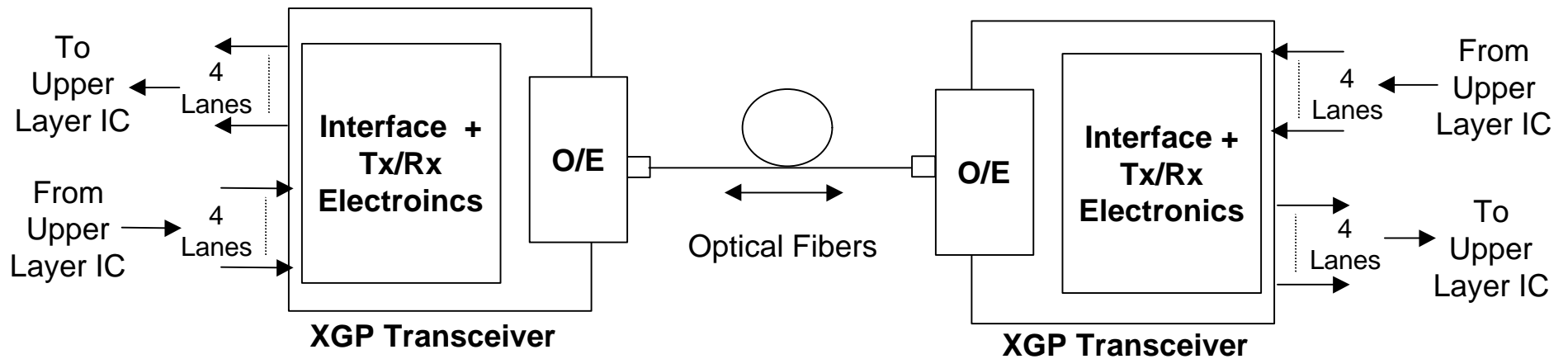

**XGP MSA**

# XGP Attachment Approach

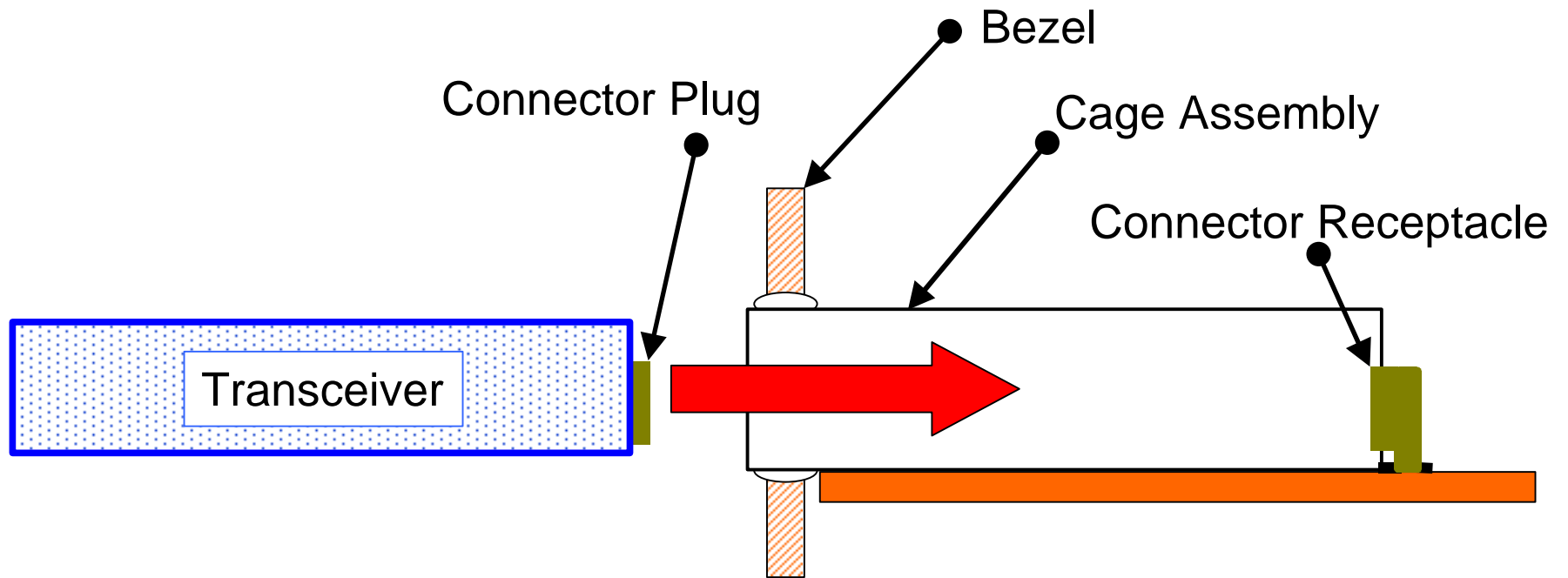

**XGP MSA**

# Status



- Ad hoc status
- Current focus on IP and operating procedures
- Multi-phase product definition process
  - Electrical connector requirements and definition
  - Form factor definition and thermal provisions
  - Guide rail/cage system
  - Optical connector and PMD variants
- Process strategy
  - Achieve maximum consensus with minimum # of variants
  - Timely development process

---

**XGP MSA**

# *Status -Continued-*



- Preliminary technical requirements being developed
- Electrical connector design approach established
  - Current “place holder” is a 50 pin Z-axis hot pluggable
- Pin assignments under development

---

***XGP MSA***

# Next Steps



- IP, operating procedures, & membership guidelines resolution
- Baseline proposal presentations at next meeting
- Pinout definition & refinement
- Face-to-face meetings every 2 months, Bi-weekly conference calls