

Proposal for Specifying PSE Detection

IEEE 802.3af DTE Power via MDI Meeting

January 2001

Dieter Knollman

AVAYA

djhk@netzero.net

PSE Detection Philosophy

- Signature Detection Criteria
 - Signature Slope Resistance within bounds
 - Small Capacitance
- False Detect Consequence
 - Small current
 - Violates Minimum Load - will be shut off
- No Detect Probability
 - Reduced by wide Detection Window

Detection Probe

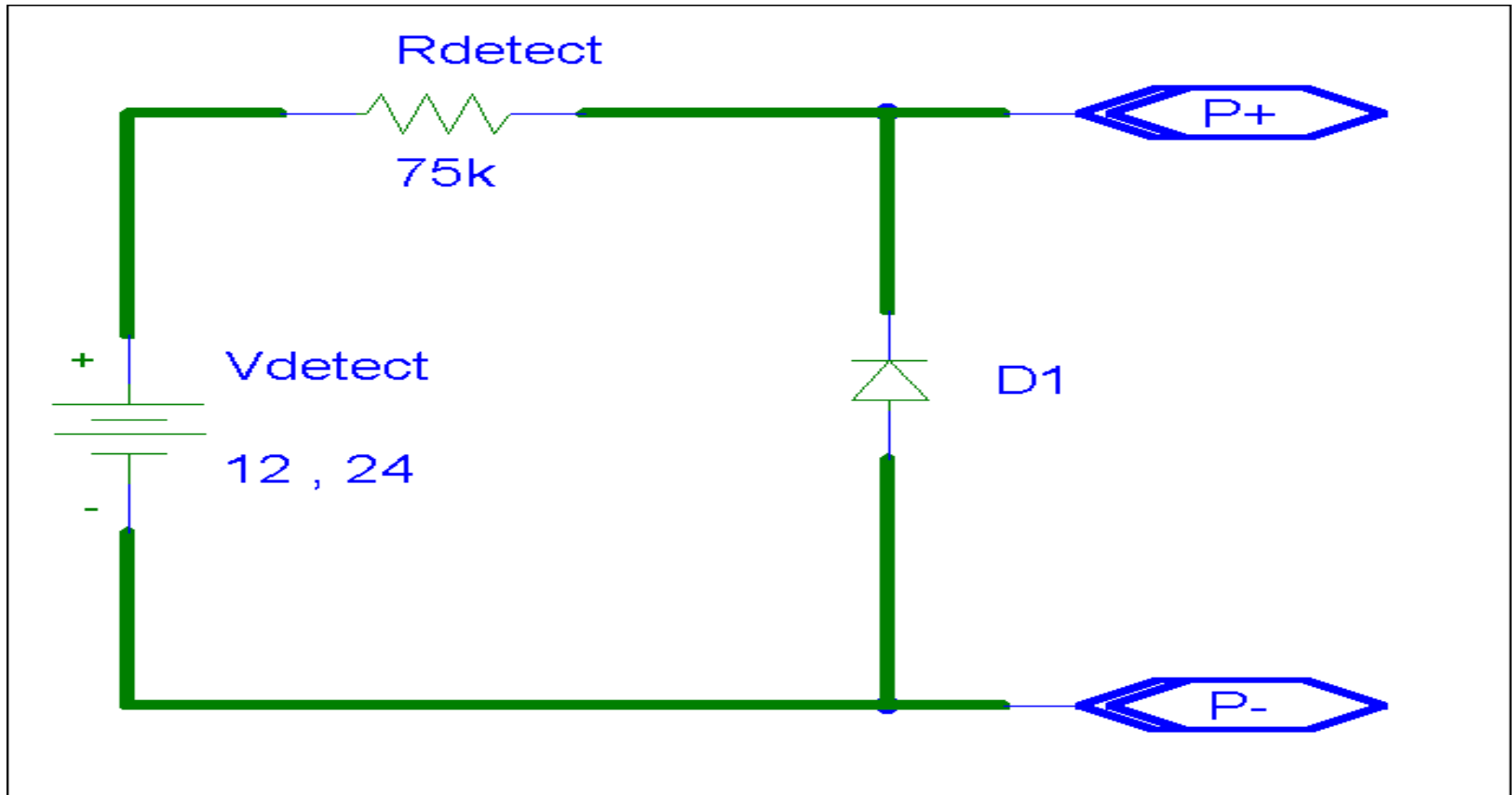

Valid PD

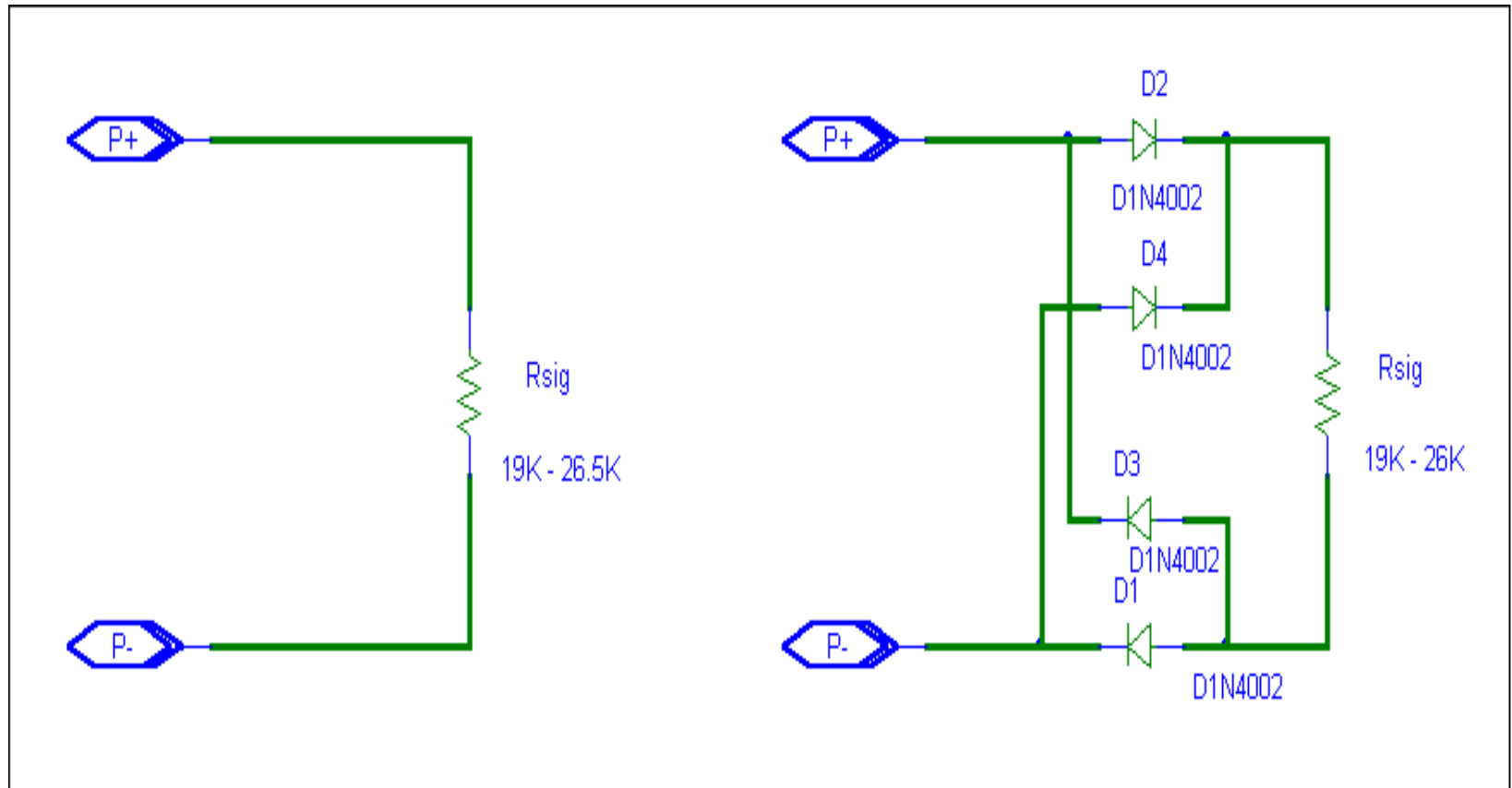

Do not Detect

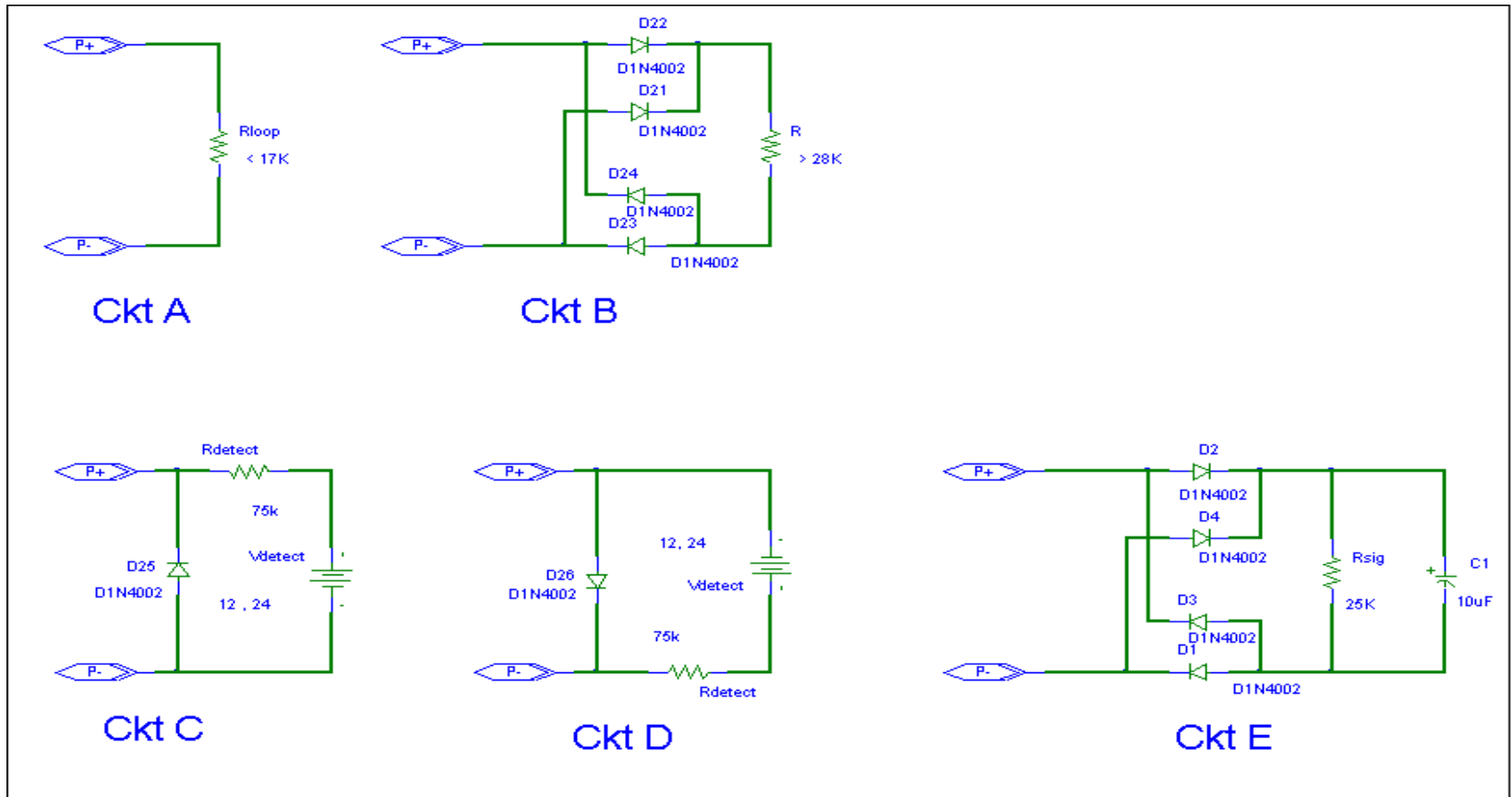

Do not Detect - Wide

