

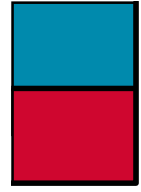

Power over the MDI using the two Signal Pairs

Karl Nakamura
karln@cisco.com

Roger Karam
rkaram@cisco.com



2 Signal Pair Operation

- **Overview**
- **Phone Discovery**
- **Power Delivery**
- **Signal Quality Impact**



2 Signal Pair Overview

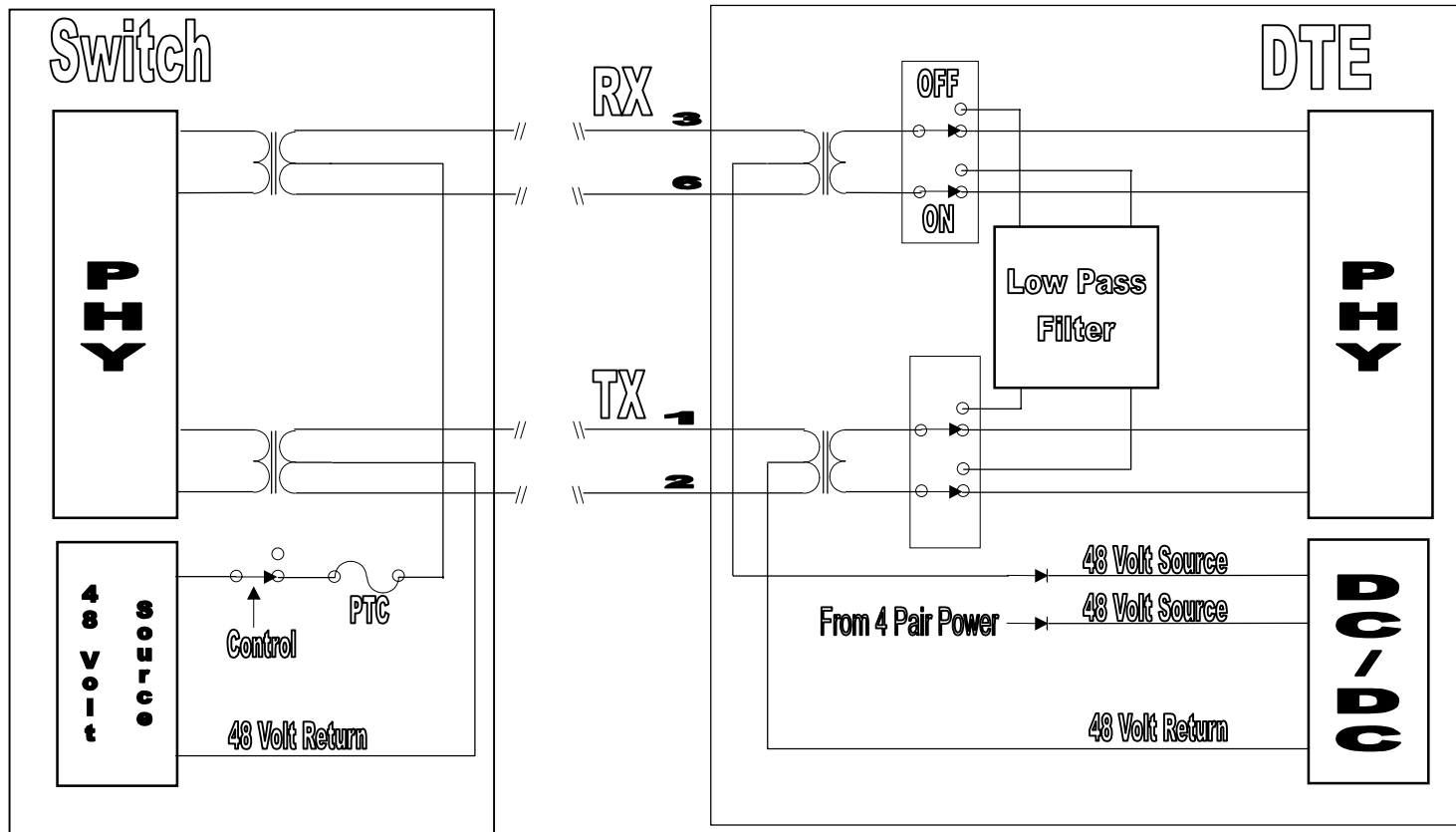



Phone Discovery

- **Using Discovery Tone in Loopback without power (see “DTE Power via MDI” by Vafa Rakshani and Kevin Brown of Broadcom on 11/8/99, 3/8/00)**
- **Each Port on Switch Individually Controlled**
- **Power from Switch up to 8-10 Watts @ 48V (see “LAN Magnetics operating under DC Bias Conditions” by Henry Heinrichs of Pulse Engineering on 11/8/99)**



Signal Quality Measurements

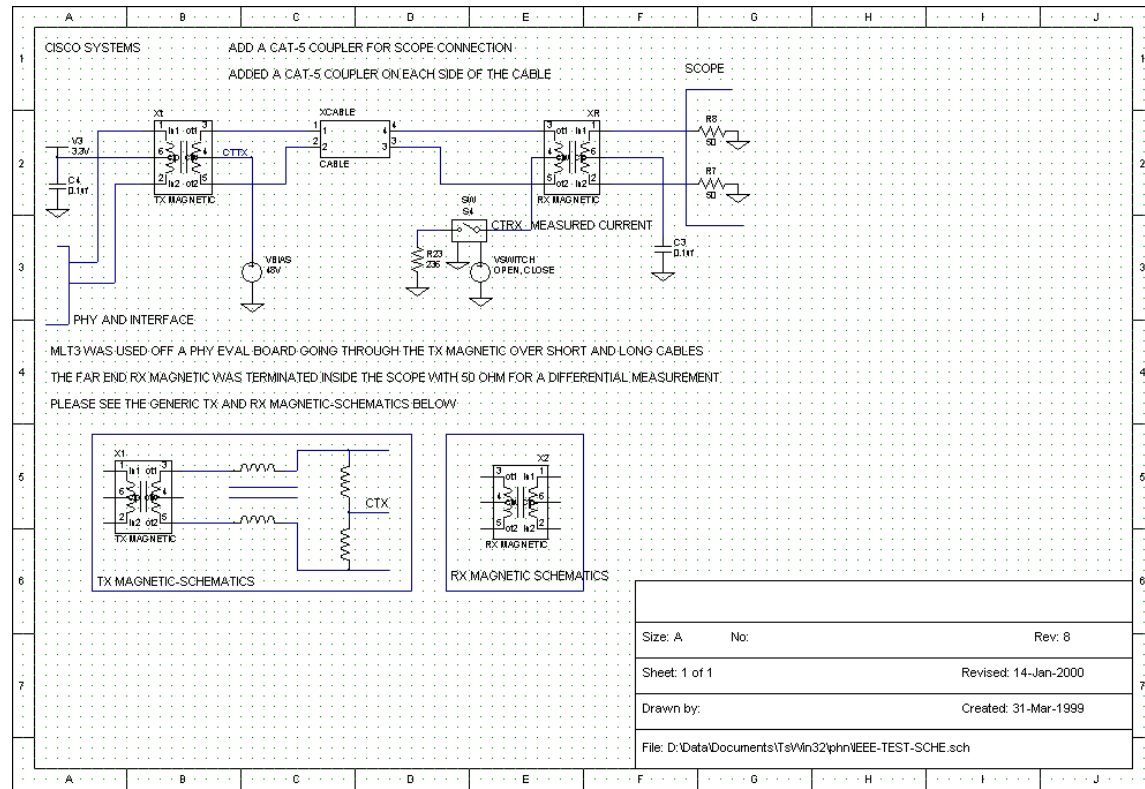



Signal Quality Measurements

14-Jan-00
9:49:50

TX EYE, SHORT CABLE AT 200mA

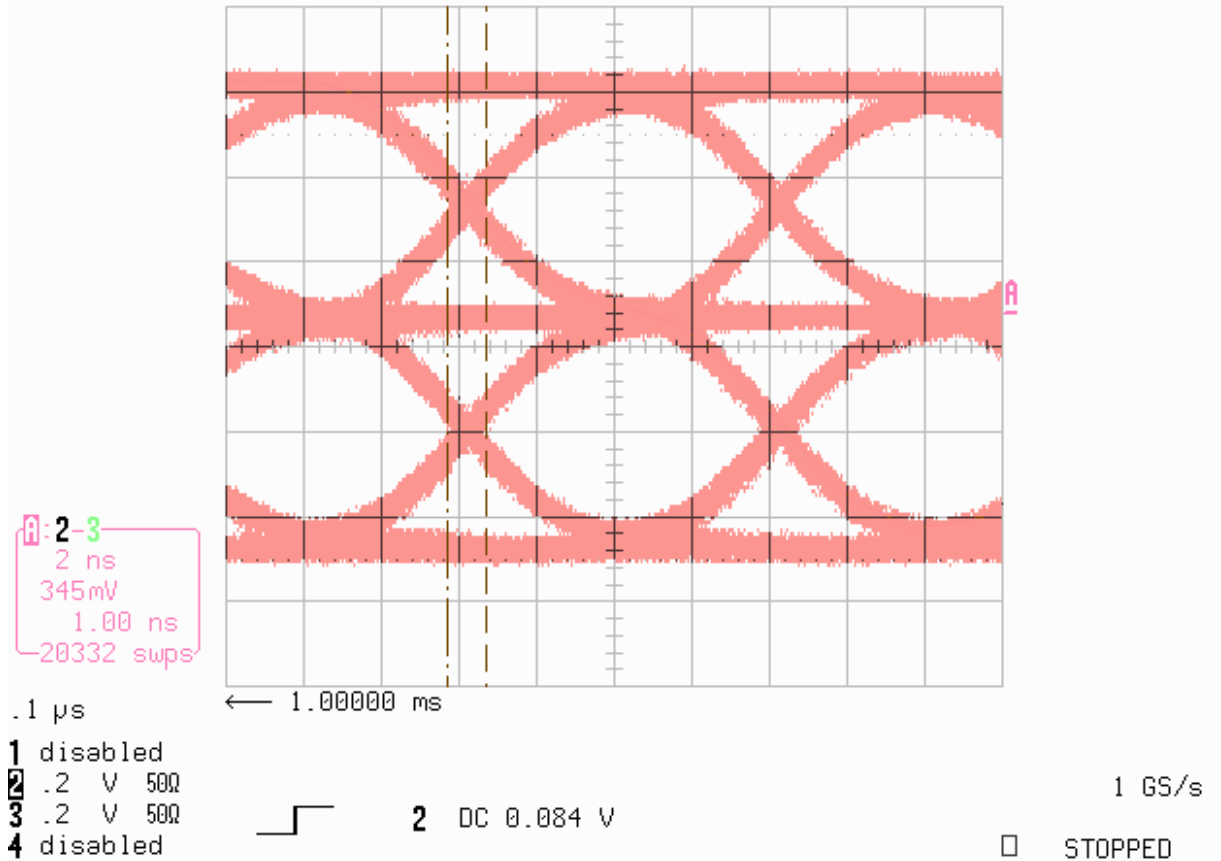



Signal Quality Measurements

14-Jan-00
9:46:41

A= TX EYE, SHORT CABLE, I=0mA

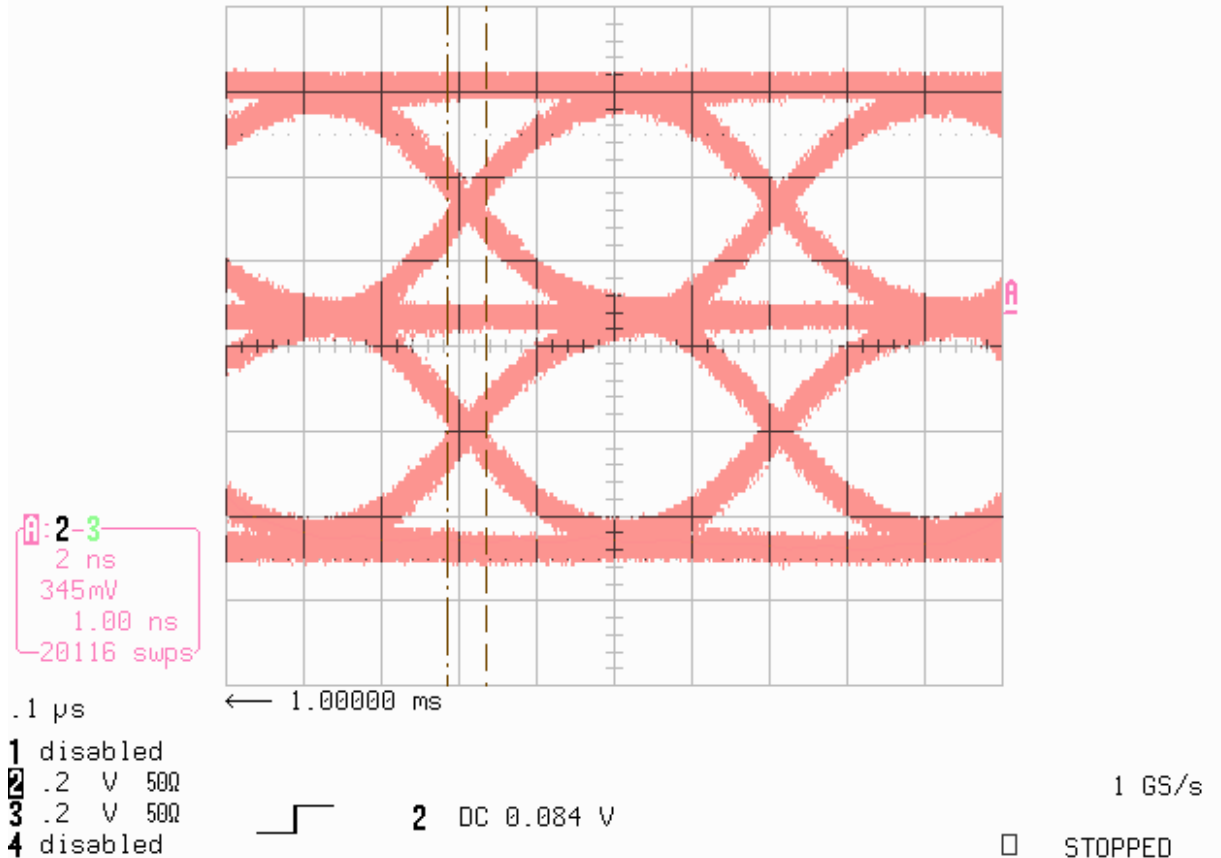



Signal Quality Measurements

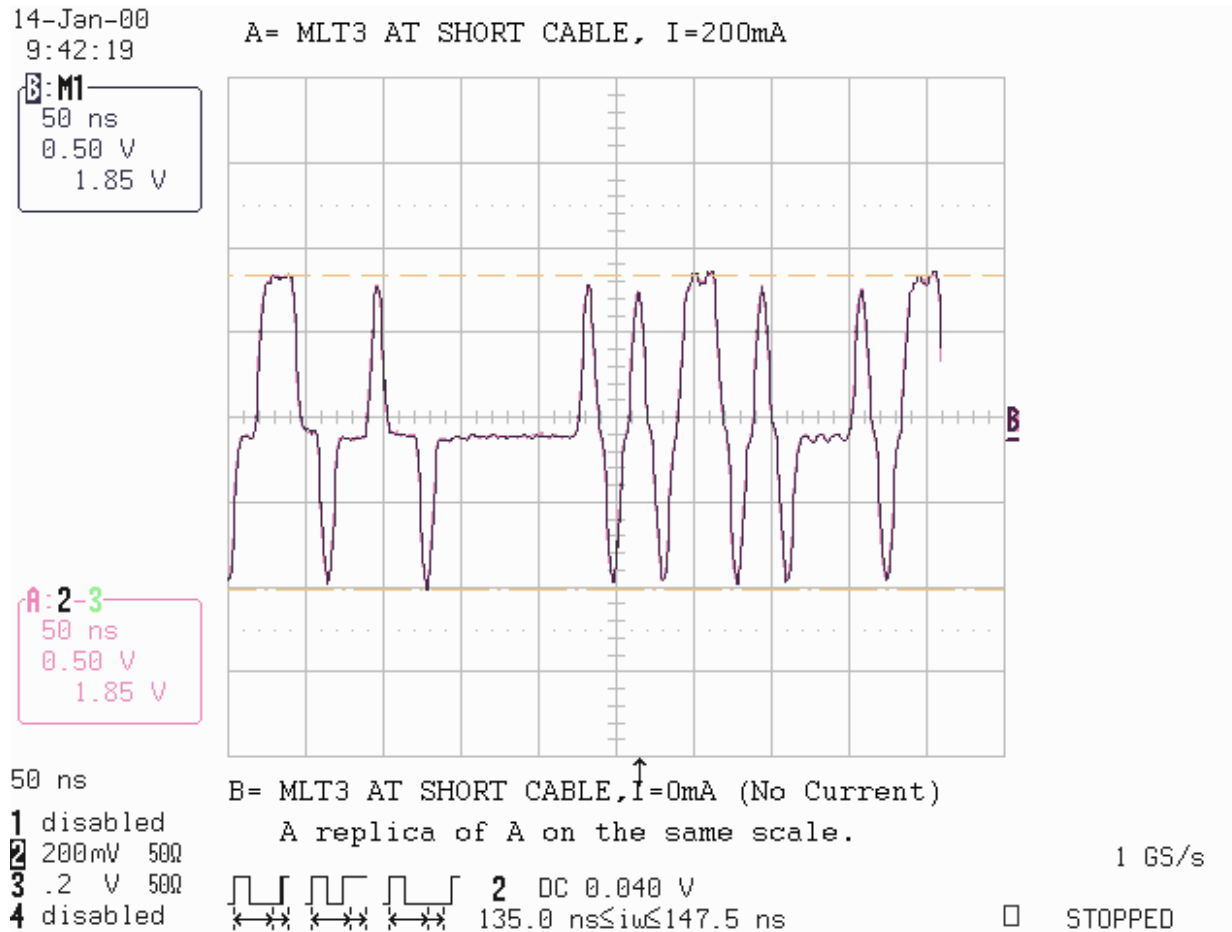

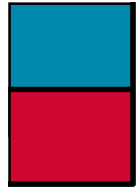

Signal Quality Measurements

14-Jan-00
10:00:14

A= MLT3 AT 120M CAT-5, I=200mA

M2
50 ns
154mV
456mV

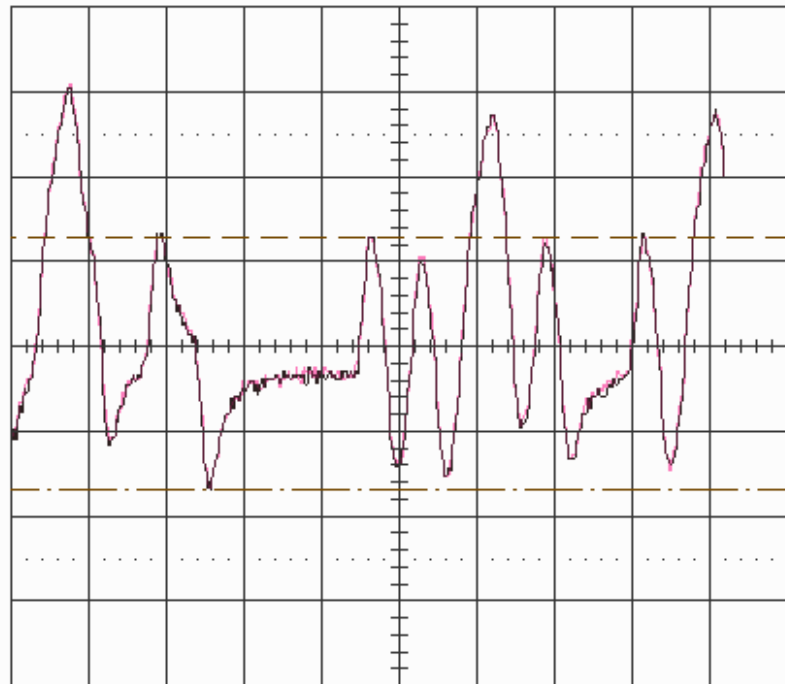

A: 2-3
50 ns
154mV
456mV

50 ns

B= MLT3 AT 120M CAT-5, I=0mA

- 1 disabled
- 2 200mV 50Ω
- 3 .2 V 50Ω
- 4 disabled



2 DC 0.040 V
135.0 ns ≤ t_{iw} ≤ 147.5 ns

1 GS/s

STOPPED

ISCO SYSTEMS



Cisco Systems



Signal Quality Measurements

14-Jan-00
9:57:29

SHORT AND LONG CABLE WAVEFORMS- REFERENCE

B: M1
50 ns
340mV
1.844 V

A: 2-3
50 ns
154mV
835mV

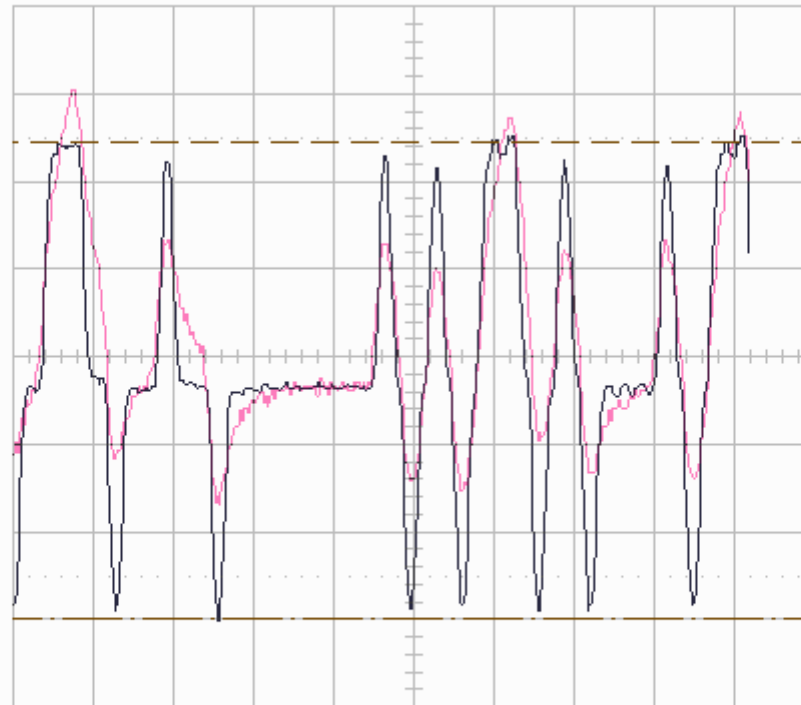

50 ns

- 1 disabled
- 2 200mV 50Ω
- 3 .2 V 50Ω
- 4 disabled

LONG CABLE = 120M OF CAT- 5, ALONG WITH 3 CAT-5 COUPLERS.
WAVEFORM A= LONG CABLE, WAVEFORM B= SHORT CABLE



2 DC 0.040 V
135.0 ns ≤ iw ≤ 147.5 ns

1 GS/s

STOPPED

Cisco Systems





Signal Quality Measurements

14-Jan-00
9:58:10

SHORT- LONG CABLE SIGNALS FOR REFERENCE

B: M1
50 ns
340mV
1.86 V

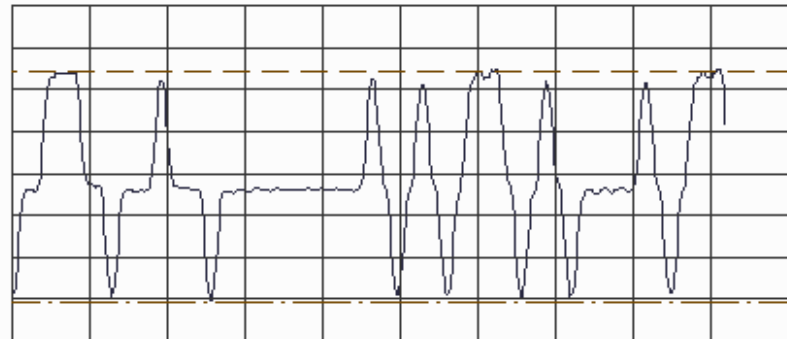

A: 2-3
50 ns
154mV
843mV

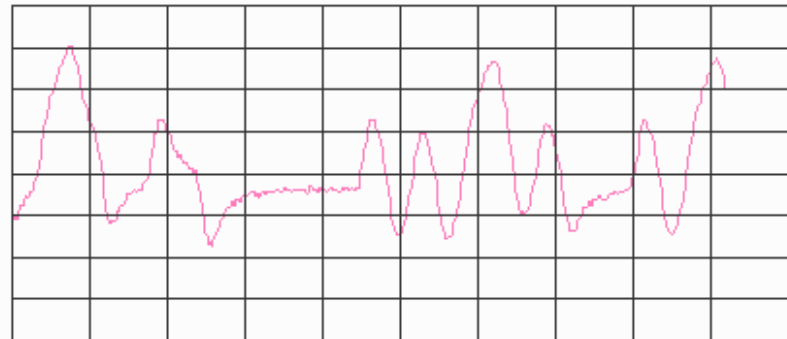

50 ns

1 disabled
2 200mV 500
3 .2 V 500
4 disabled



2 DC 0.040 V
135.0 ns ≤ iu ≤ 147.5 ns

1 GS/s

STOPPED

Cisco Systems

SCO SYSTEMS





Detection Pulses

15-May-00
16:53:53

C: 2-3
.5 μ s
300mV

A: M1
.5 μ s
300mV

B: M1
.5 μ s
280mV

M1
.5 μ s
1.00 V

Detection Pulses, 0m, 120m Cat-5, 300FT Cat-3

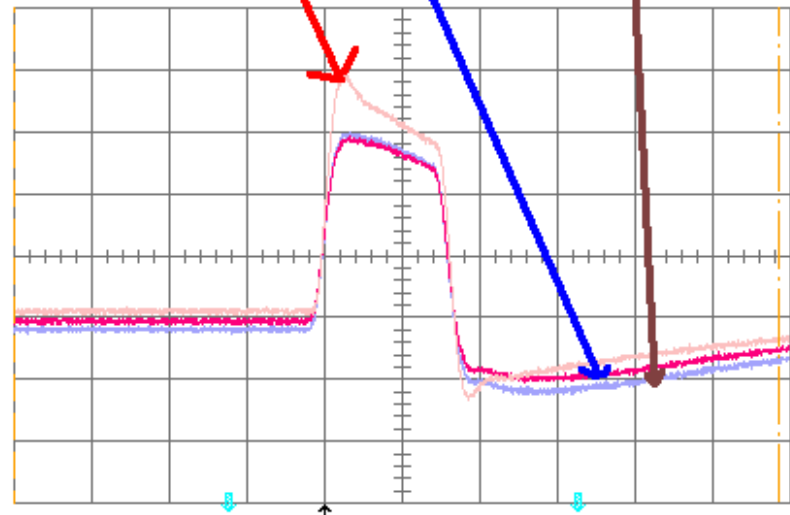

	28 sweeps:	average	low	high	sigma
ampl(C)		1.172 V	1.156	1.391	0.043
width(C)		762.29 ns	759.37	764.23	0.97
Freq(C)		---	---	---	---

.5 μ s

1	.5	V	AC	\times
2	.2	V	50 Ω	
3	.2	V	50 Ω	
4	.1	V	DC	\times

Top pulse=0m, bottom two are round-trip via 120m of Cat-5 and 300Ft of Cat-3 cables via relays +mag



2 DC 0.172 V

2 GS/s

AUTO

Cisco Systems





Return Loss (No Current)

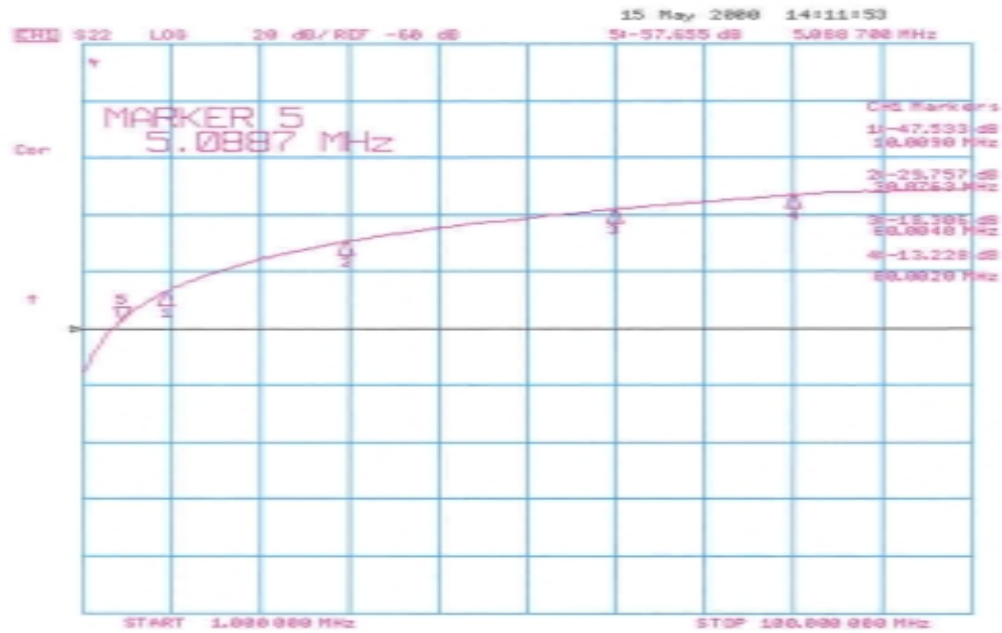

* R LOSS / NO CURRENT

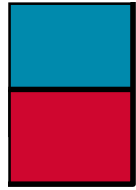

Return Loss(With Current)

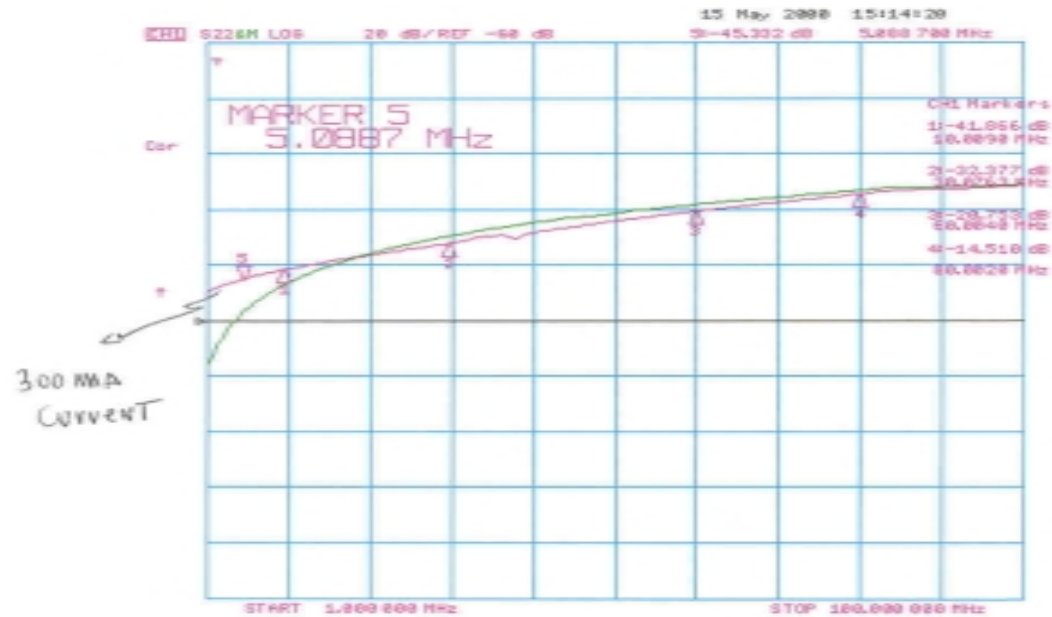

* Return loss with 300mA/ 300 MA

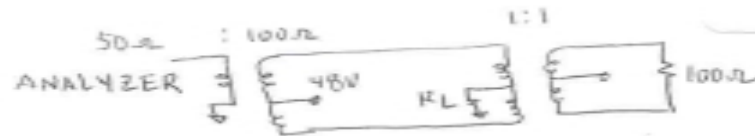

Cisco Systems





Advantages of 2 Signal Pair Powering From the Switch

- **Preserve 2-pairs legacy wiring**
- **No Patch Panel Work for New Line Cards**
- **Does not lock us in mid-span powering for ever**
- **No Patch Panel Work for Gigabit Ports**
- **No additional Rack Space Required**
- **Few Components needed on the Switch/DTE**
- **Isolated side of the Magnetics Features:**
 - 2000V Isolation and ESD Protection**
 - Differential Signaling**
 - Meets IEEE 802.3 SPECIFICATIONS**
- **EMI Tested and Verified to meet FCC Class B limits at the DTE and the Switch**

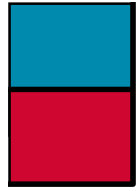

Integration Path for the Future

