

Improved PRBS31 testing

Piers Dawe

Avago Technologies

Supporters

Chris Cole

Finisar

Module testing

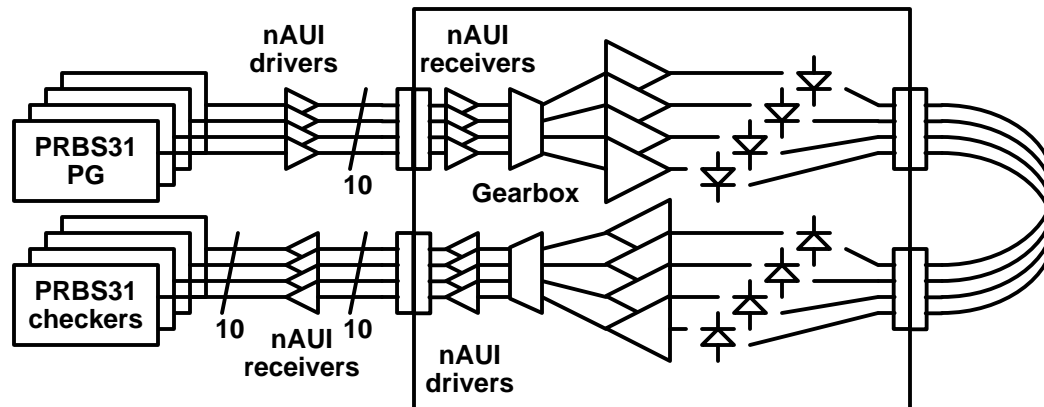

Example 1
100G module
tested from
electrical side

Example 2
100G module
tested from
optical side

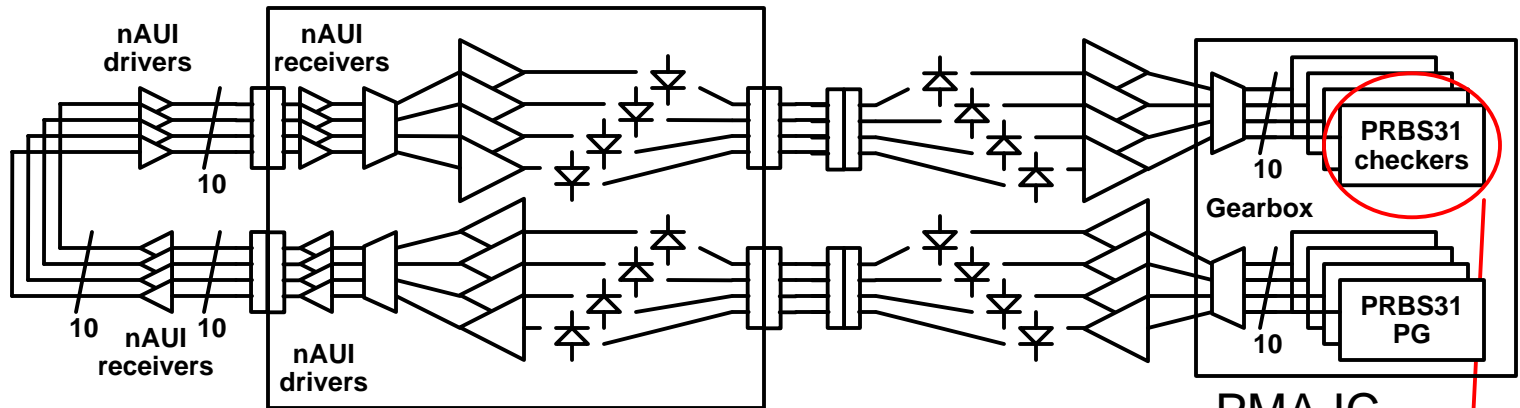

PMA IC
used as a
tester **See later**

- Want to test **WHOLE** module
 - without assuming that its internal ICs are working perfectly
 - May expect Ethernet switch to check out a new module as in example 1

Module testing cont.

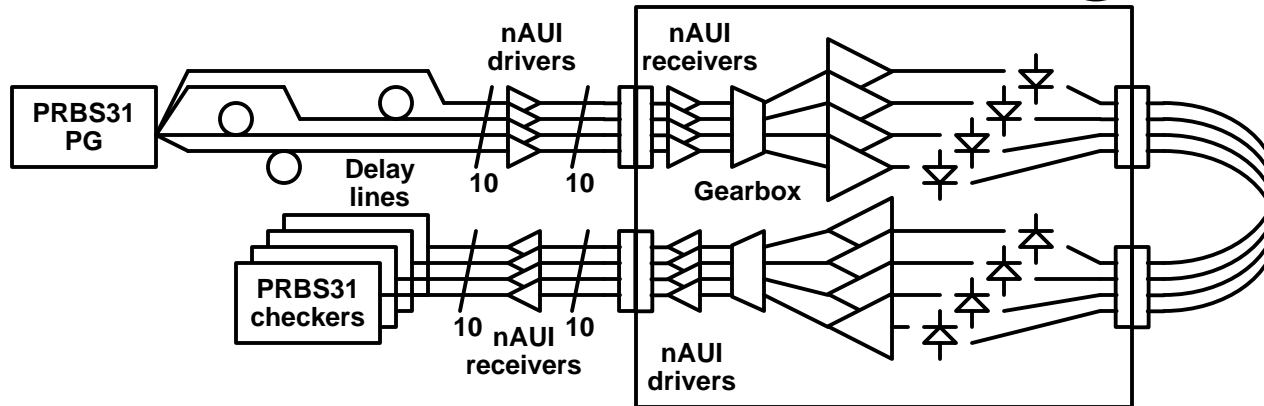

Example 3
Module tested
from electrical
side, single PRBS
generator

- Want to keep test costs down
- Existing 10G test equipment much cheaper than new or 25 G test equipment

Problem and solution

PRBS31 generators can remain at 10G

Not all nAUI lanes contain intact PRBS31s

Each contains two interleaved PRBS31 at PCS lane rate

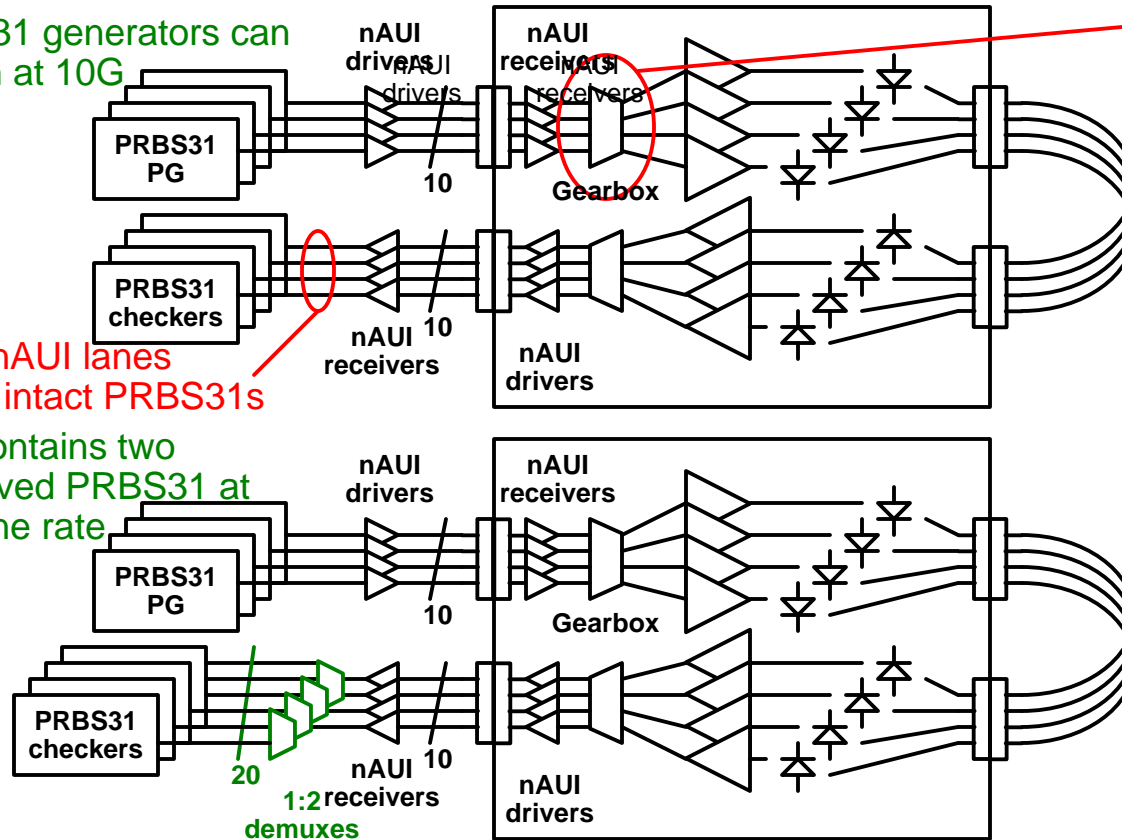

100G Gearbox has to split up at least 2 of the 10 nAUI lanes and divide them across 5G lanes

No equivalent problem for 40G

- Hypothetical "serial" error checkers shown
- In practice, signal inside IC would be more parallel than this (<5G per lane) anyway
- Therefore VERY few extra gates needed

Choices

1. Check PRBS31 per nAUI lane, report errors per nAUI lane
 - As D1.2
2. Check PRBS31 per PCS lane, report errors per nAUI lane (add pairs of error counts together)
 - "Backwards compatible" with D1.2
 - Both the patterns it can check and the registers that report the error count are backwards compatible
3. Check PRBS31 per PCS lane, report errors per PCS lane
 - Might allow more thorough error tracing in rare cases?
 - Still can check PRBS31 generated per nAUI lane, 10 more counter registers
 - PMA test pattern generation and detection is optional
 - If PMA check Rx PRBS31 implemented, propose implementer can use options 1 or 2 as above
 - Rx side checkers only or Rx side and Tx side?
 - Don't see much use for Tx side error checking after 4:10 gearbox

Summary

- D1.2 PRBS31 error checkers in PCS are not as useful as they should be
 - Can't always parse a 10G lane after a 100G gearbox
 - No problem for 40G
 - Solution is to check PRBS31 at the 5G (PCS lane) level rather than 10G (nAUI lane)
 - No need to modify PRBS generators
 - Modify text in 83.5.10. Make the improvement optional
 - Report error count by nAUI lane (still 10 counters, no need to change 45.2.1.12d)
 - If want to report all 20 PCS lane error counts, modify 45.2.1.12d