

Overview of IEEE P802.3bf

Steve Carlson, IEEE P802.3bf Chair

David Law, IEEE 802.3 WG Chair

Marek Hajduczenia, IEEE P802.3bf Chief Editor

This contribution reuses material from law_1_0110.pdf
submitted to the IEEE 802.3bf Interim Meeting, New Orleans, January 2010 and
siepon_1002_hajduczenia.pdf

IEEE P802.3bf Background

- Before 802.3bf TF was formed ...
 - Work on Ethernet time synchronization started in 2004 within the Residential Ethernet Study Group (RESG SG) in IEEE 802.3 WG
 - RESG determined that the project was best suited for IEEE 802.1 WG
 - Effectively, IEEE 802.1 WG created the Audio-Video Bridging Group (802.1 AVB)
 - At the time, it was understood that there would be an 802.3 component to support the 802.1 AVB work

IEEE P802.3bf Background

- and where IEEE 802.3 is now...
 - Ethernet Support for the IEEE P802.1AS Time Synchronization Protocol Task Force (IEEE 802.3bf) started work in January 2010
 - IEEE P802.3bf is also commonly referenced to as “Time Sync” for short
 - IEEE P802.3bf Draft 0.3 is current as of 2010.05
 - draft 0.4 is expected to be released out of May 2010 meeting
 - IEEE P802.3bf intends to request Working Group ballot in July 2010
 - on draft 0.4
 - might be updated to 1.0 to keep numbering consistent ...

IEEE P802.3bf Objectives

- **Formal objectives:**

- Provide an accurate indication of the transmission and reception initiation times of certain packets as required to support IEEE P802.1AS.

- **Informal objectives:**

- Restrict changes to IEEE 802.3 base document
- Provide PHY agnostic solution, capable of supporting existing and future 802.3 PHYs
- Provide open architecture, which can be scaled to higher data rate PHYs

IEEE P802.3bf Architecture

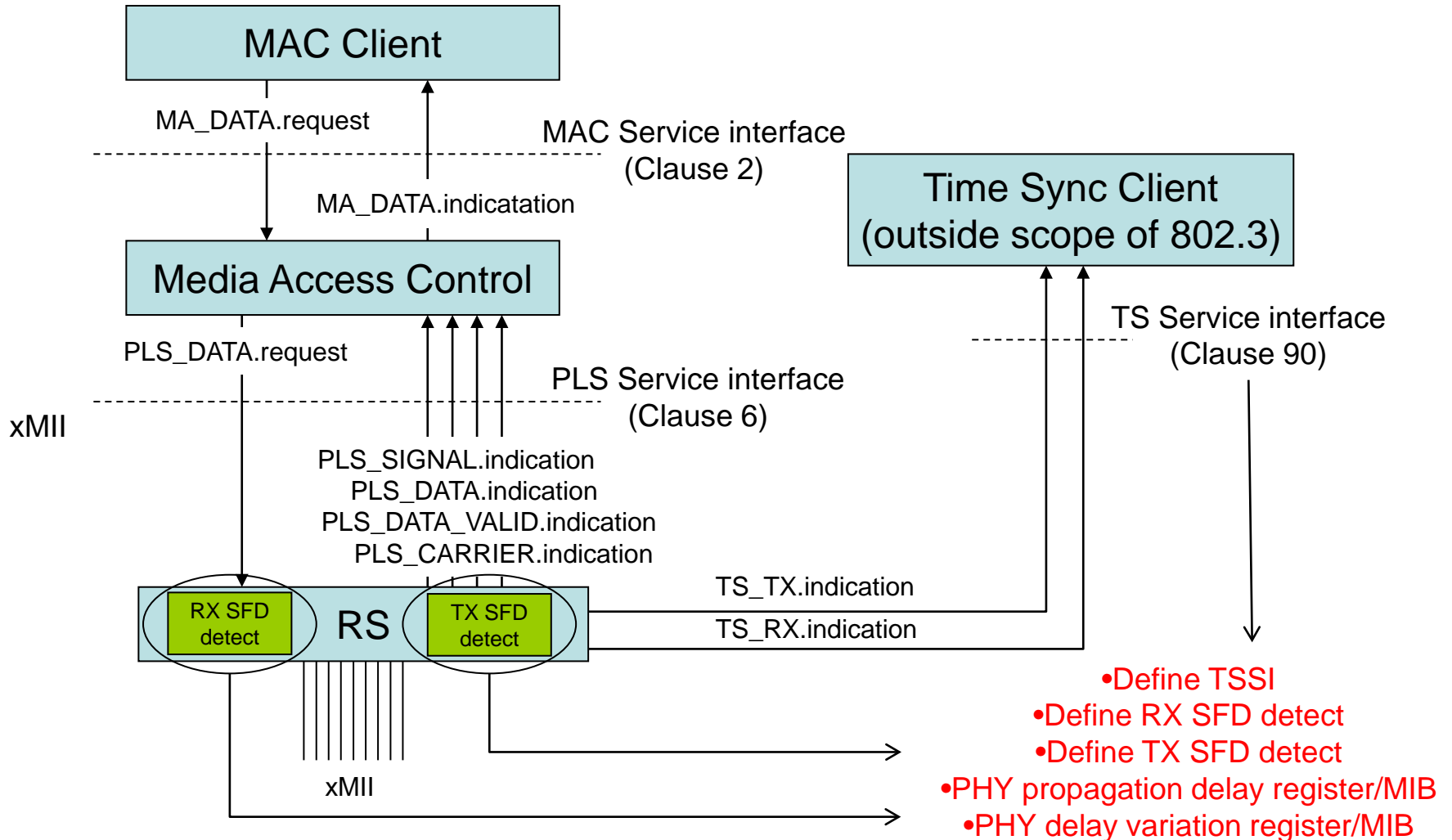

Service primitive generation – downstream (simplification)

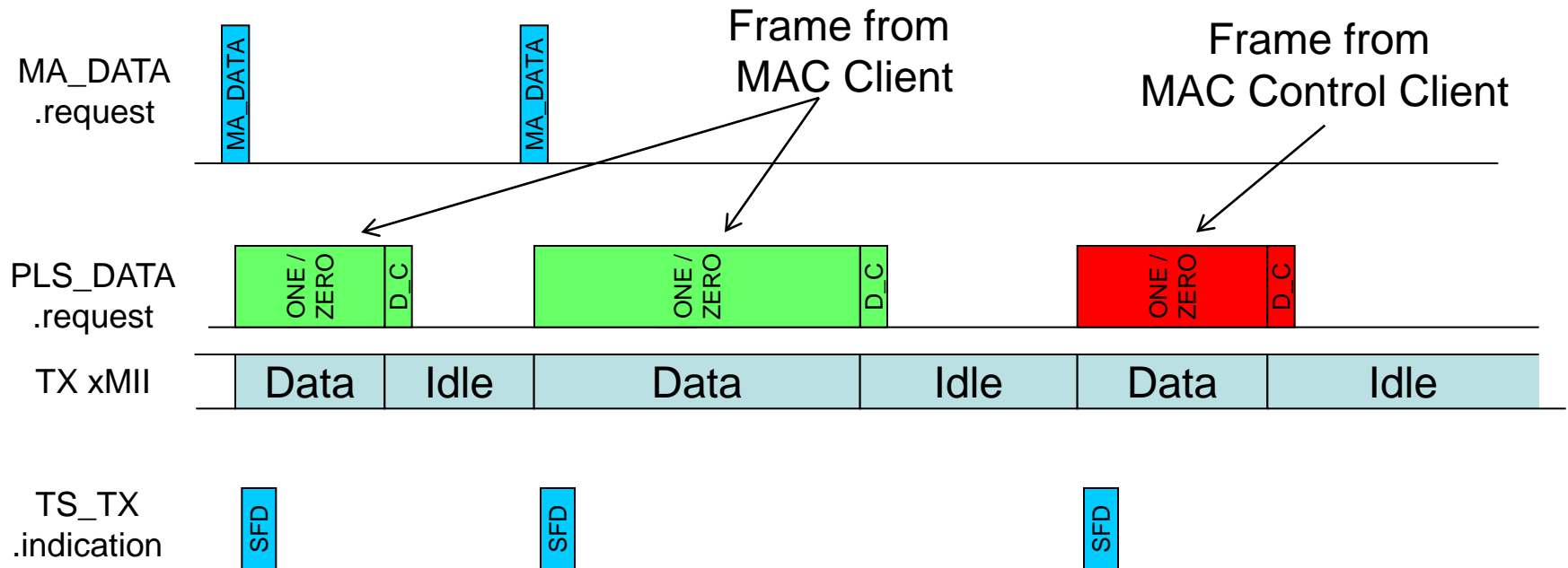

- Frames may be generated by MAC Control Client and not by MAC Client
 - In that case, MA_DATA.request is not generated (nothing is passed through the MAC Service Interface)
 - TS_TX.indication will be generated nonetheless (there is a frame passed through the xMII)

Service primitive generation – upstream (simplification)

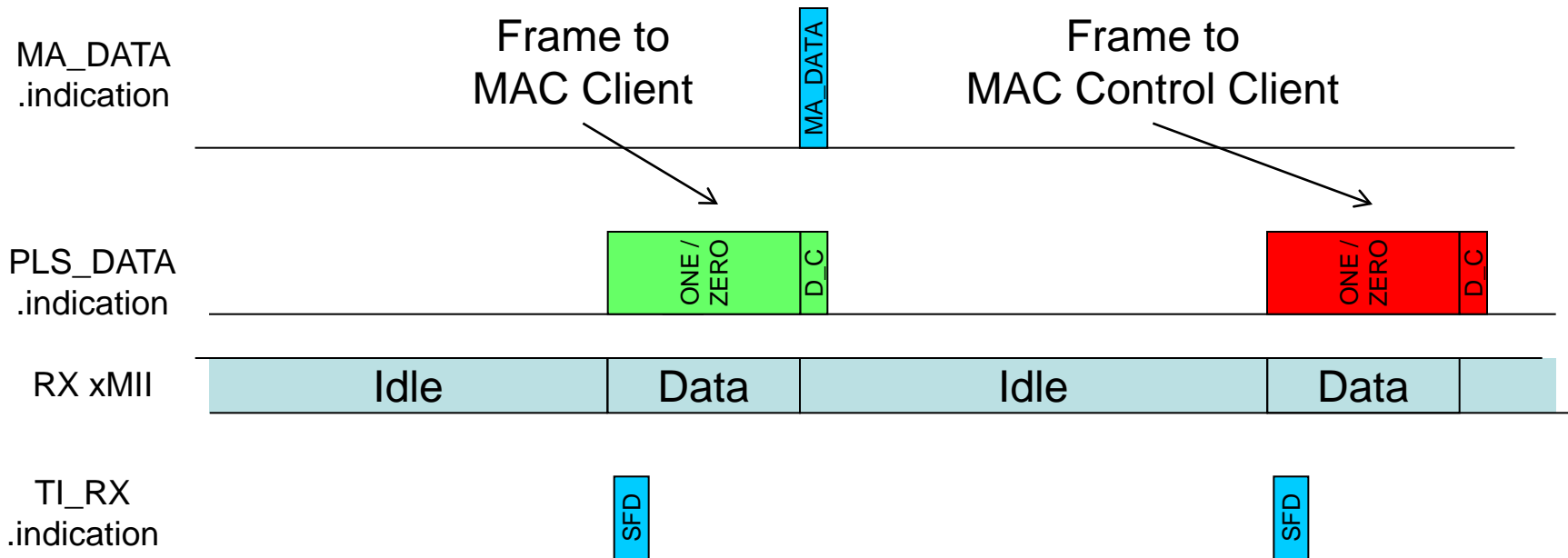

- Frames may be addressed to MAC Control Client and not to MAC Client
 - In that case, MA_DATA.indication is not generated (nothing is passed through the MAC Service Interface)
 - TS_RX.indication will be generated nonetheless (there is a frame passed through the xMII)

IEEE 802.3bf applications

- Provides an accurate indication of the transmission and reception times of all packets
 - direct use case in IEEE 802.1AS
 - there is nothing preventing other use cases as well
 - TSSI is defined in an abstract manner and it is not bound to a specific PHY / PHY class
 - IEEE 1588v2 could also directly use P802.3bf TSSI interface for support of transparent clocks

IEEE 802.3bf project information

- **Primary website**
 - <http://www.ieee802.org/3/bf/>
- **Public folder**
 - <http://www.ieee802.org/3/bf/public/index.html>
- **Private folder (including the draft)**
 - <http://www.ieee802.org/3/bf/private/>
- **IEEE 802.3bf PAR**
 - <http://www.ieee802.org/3/bf/P802.3bf.pdf>
- **IEEE 802.3bf 5 Criteria**
 - http://www.ieee802.org/3/time_adhoc/P802_3bf_5Criteria_802_3_approved_1109.pdf
- **IEEE 802.3bf Objectives**
 - http://www.ieee802.org/3/time_adhoc/P802_3bf_objective_802_3_approved_1109.pdf
- **Email reflector**
 - <http://www.ieee802.org/3/bf/reflector.html>